

CUSTOMER DRAWING

REV.	DESCRIPTION	APPROVED BY	DATE	ECN NO.
A	RELEASE	Fido Weng	02/11/11'	
B				
C				

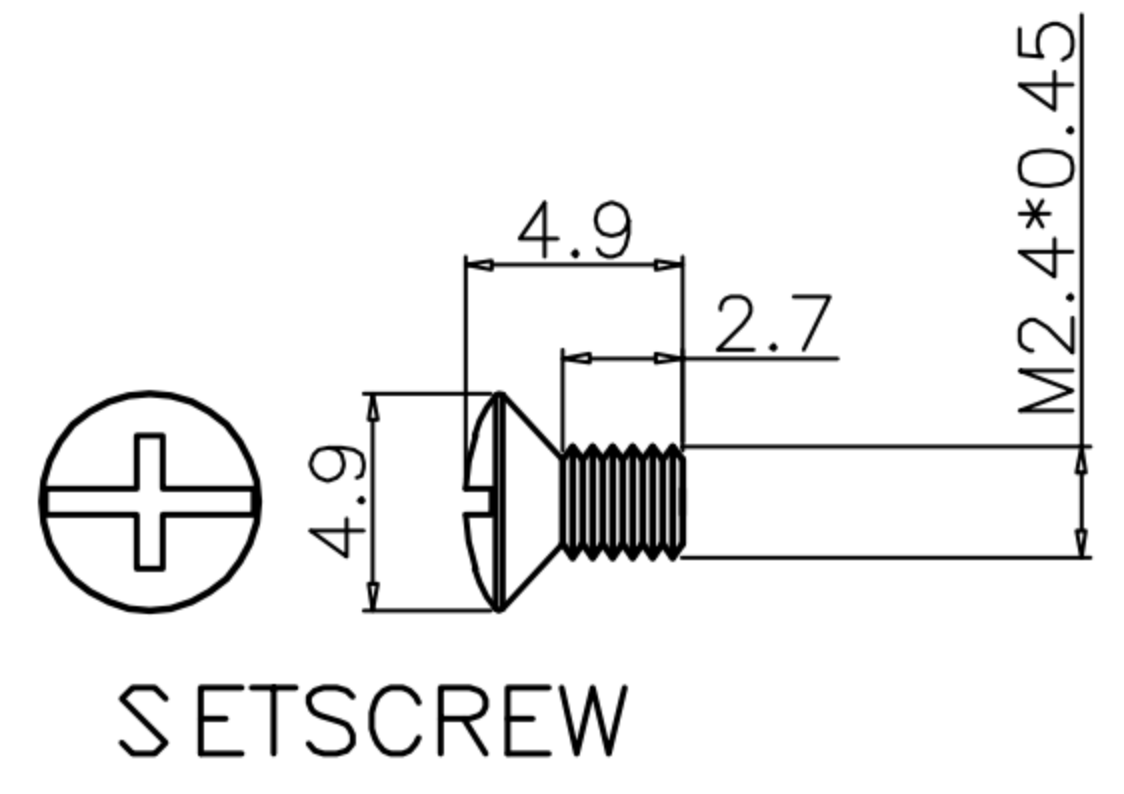

DRAWN	Ku Chou	APP'D	Emily Suen	UNIT	mm	TOLERANCE		广东科斯达电子科技有限公司 GUANG DONG KE SI DA ELECTRONIC TECHNOLOGY CO., LTD.	TITLE	270° MALE DIN CABLE PLUG			SHEET	
CHK'D	Emily Suen			SCALE	1:1				PART NO.	SEE TABLE A	DWG NO.	QC5608	VERSION	

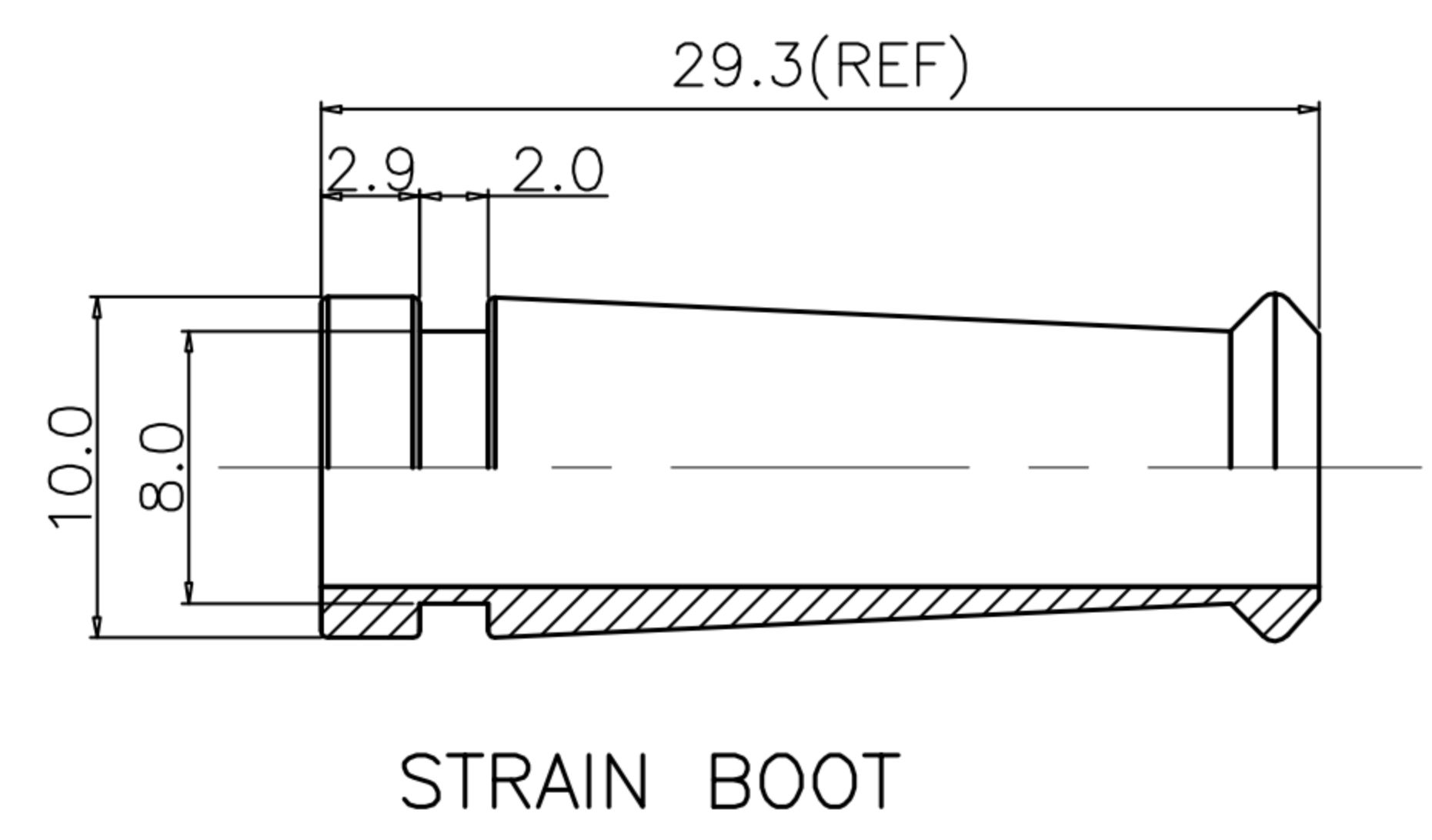
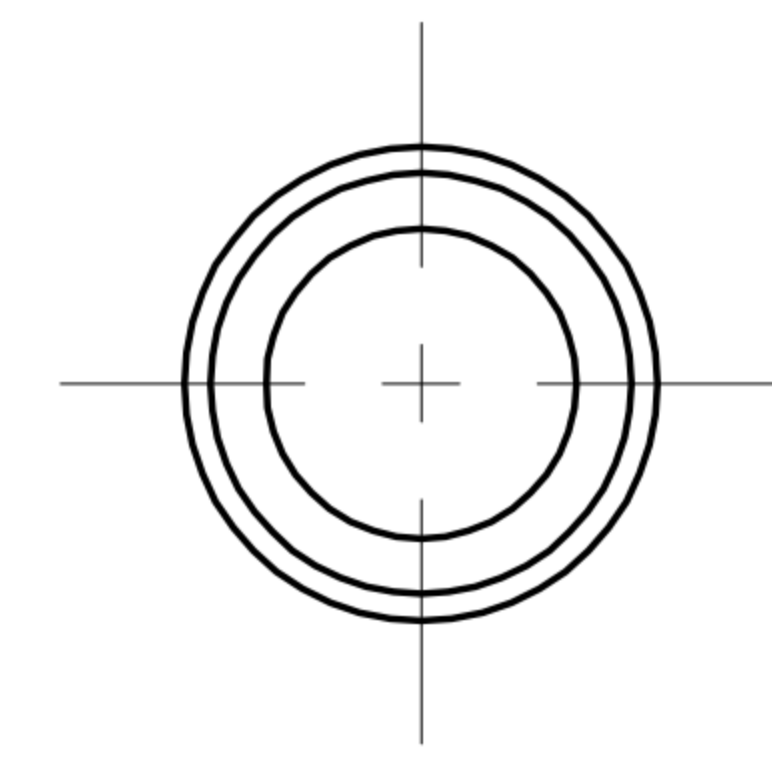
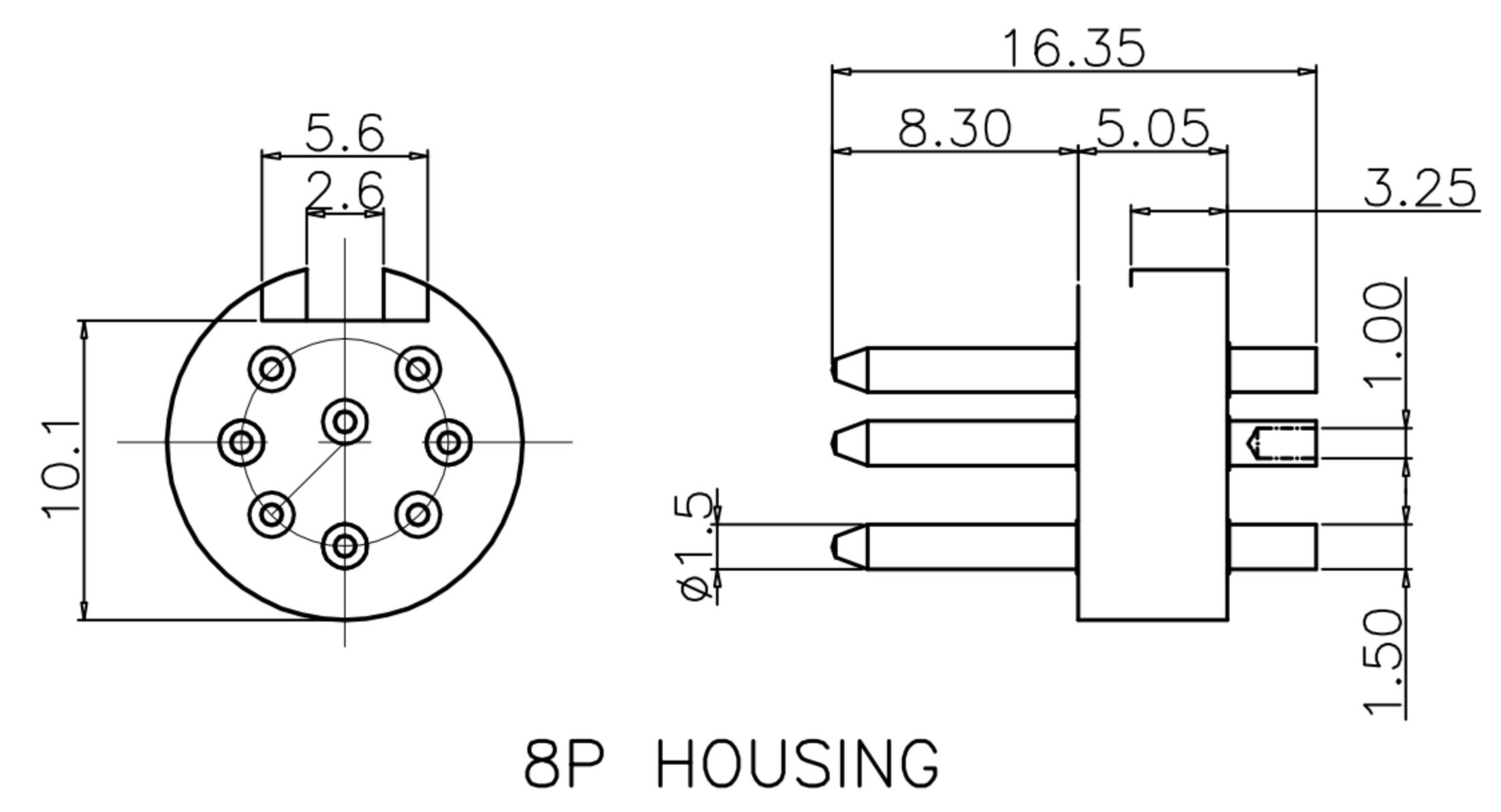
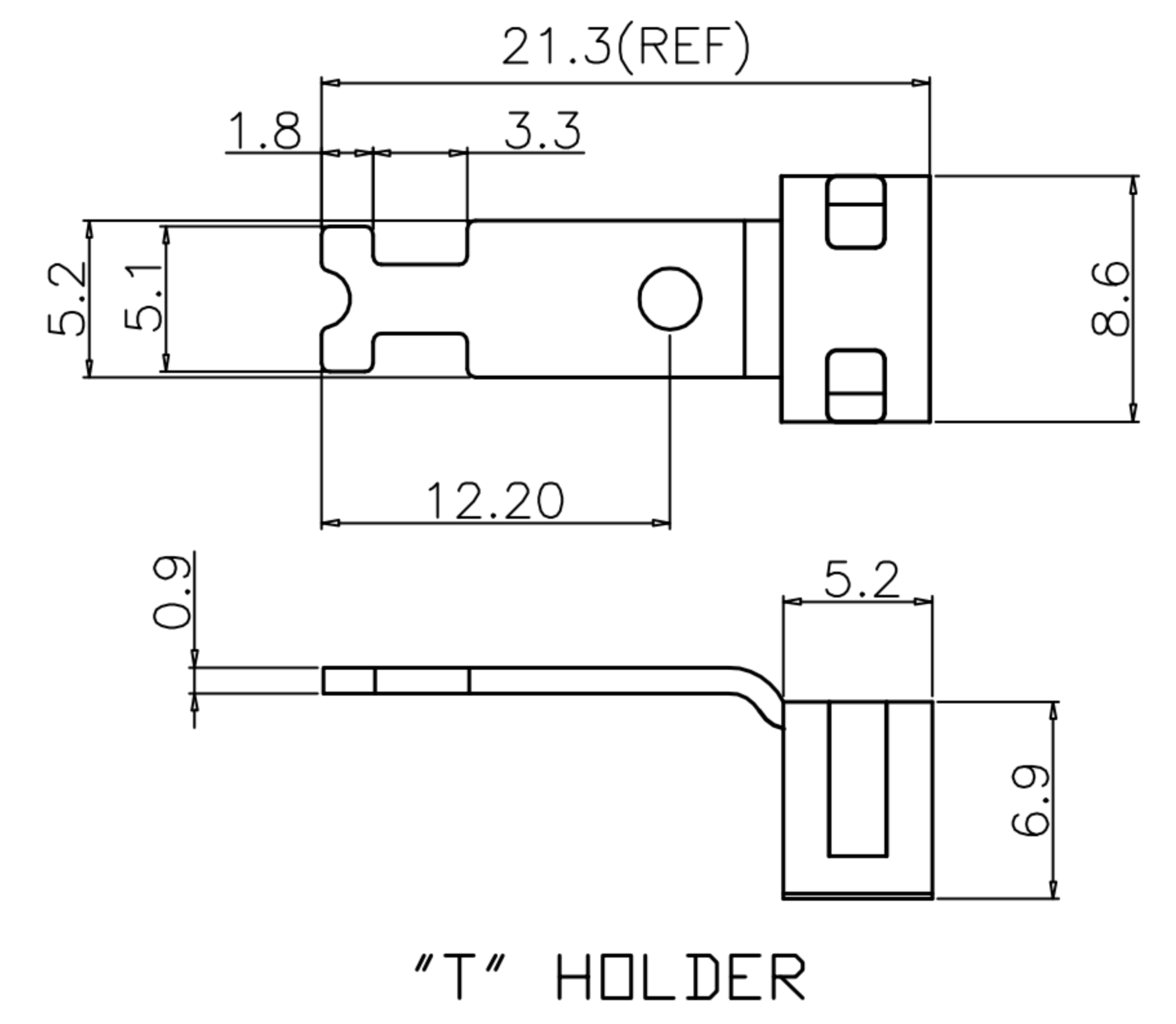
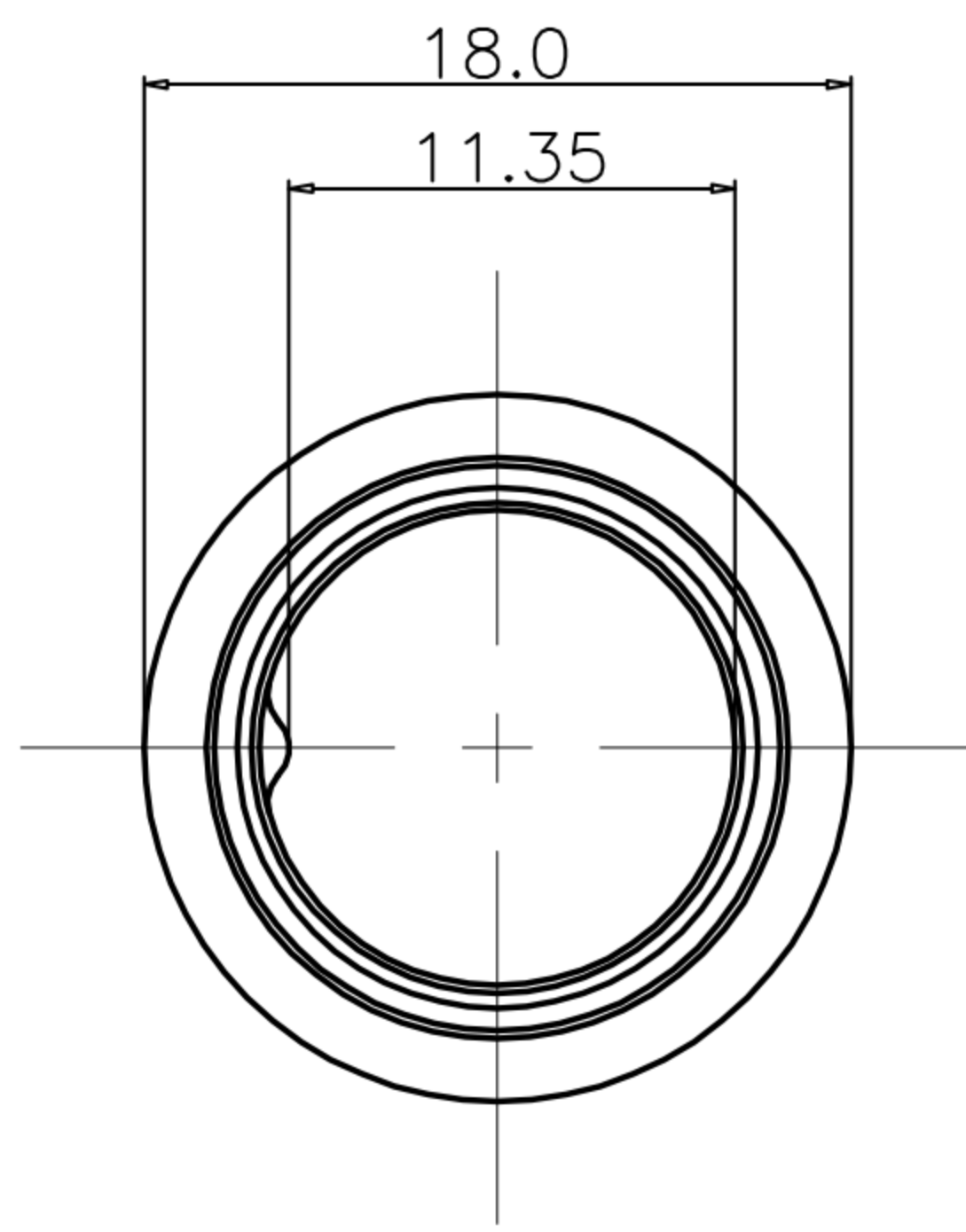
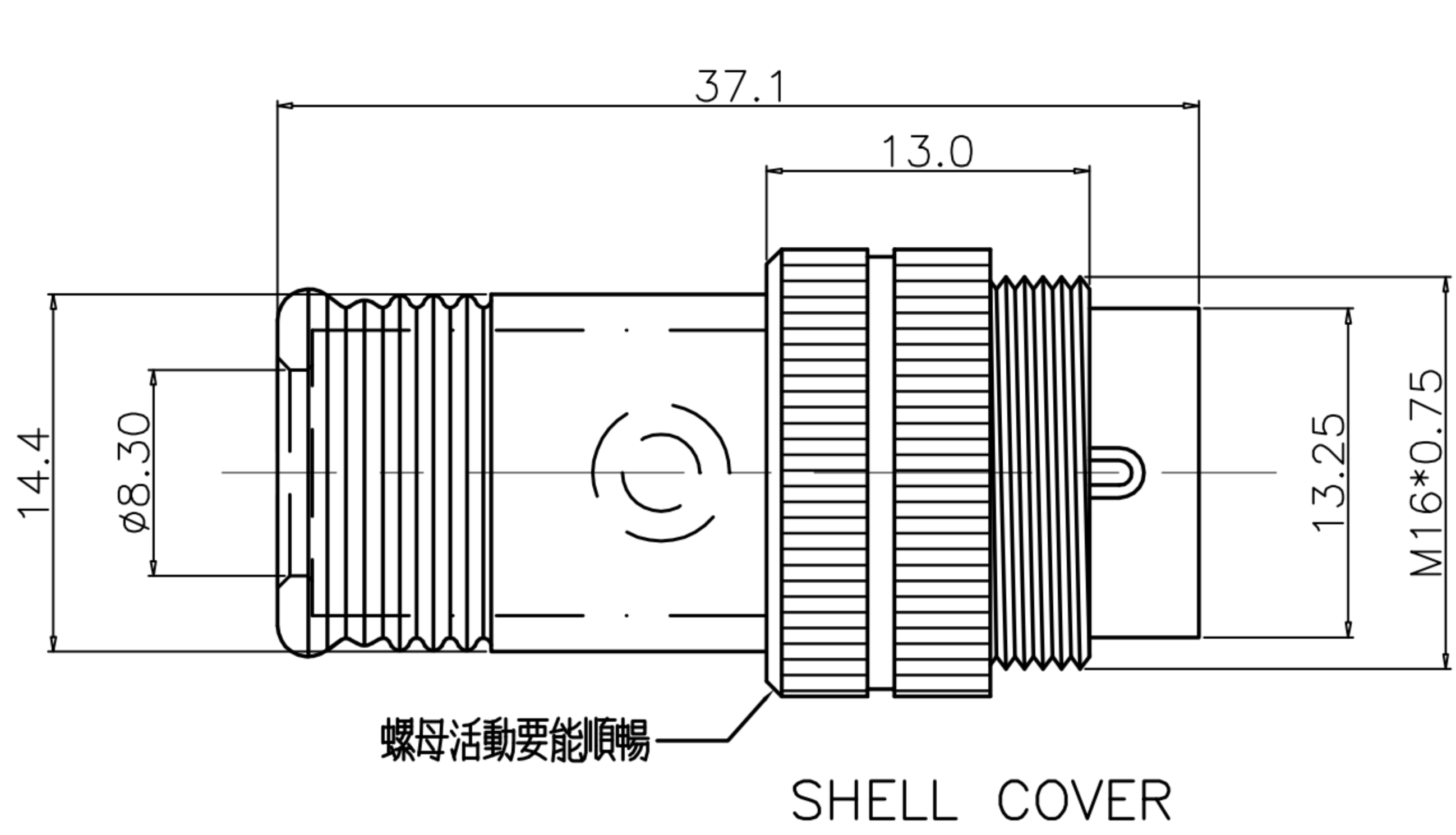

A B C D E F

CUSTOMER DRAWING

REV.	DESCRIPTION	APPROVED BY	DATE	ECN NO.
△A	RELEASE	Fido Weng	02/11/11'	
△B				
△C				

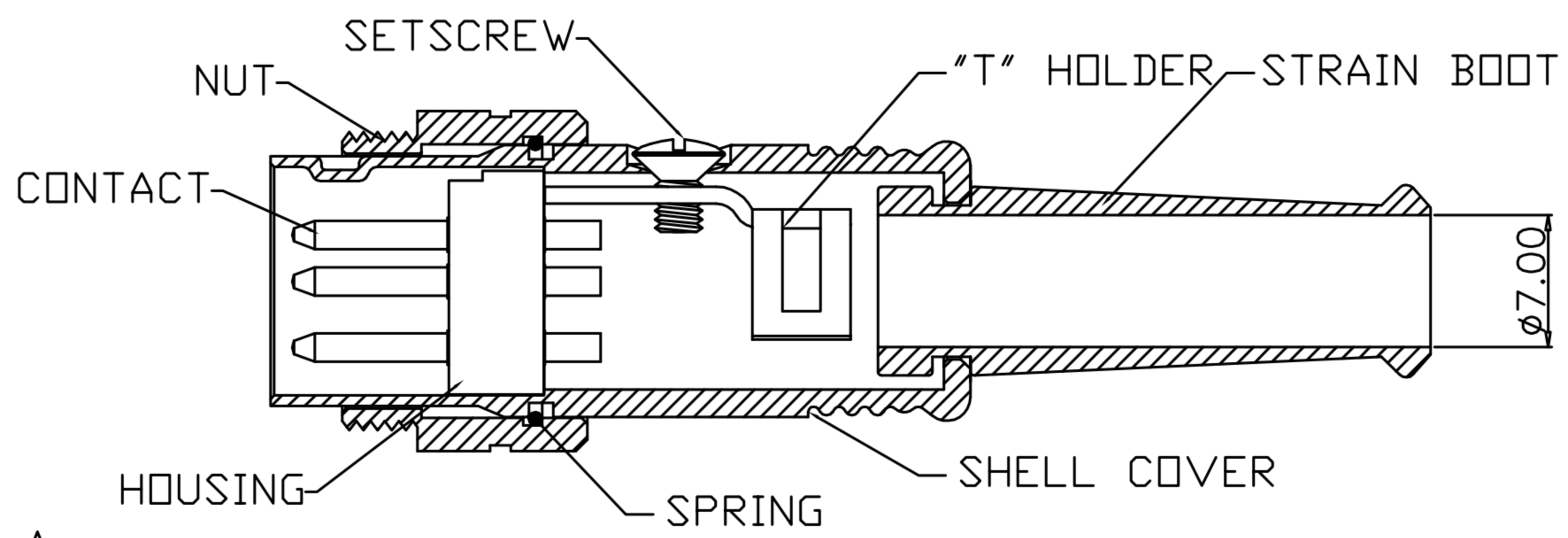
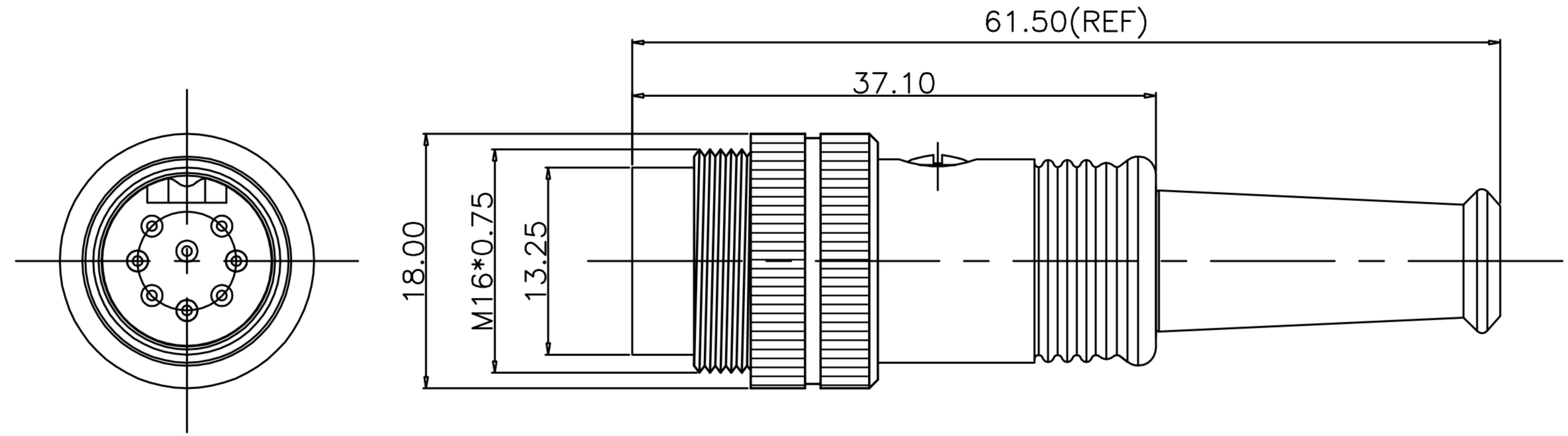

1. MATERIAL :
  - 1-1. HOUSING : PA66 ; COLOR : BLACK.
  - 1-2. CONTACT : BRASS.
  - 1-3. NUT : BRASS.
  - 1-4. SETSCREW : SPCC STEEL.
  - 1-5. "T" HOLDER : SPCC STEEL.
  - 1-6. STRAIN BOOT : TPR ; COLOR : BLACK.
  - 1-7. SHELL COVER : BRASS.
  - 1-8. SPRING : STAINLESS STEEL.
2. FINISH :
  - 2-1. CONTACT : SILVER PLATED OVER ALL
  - 2-2. NUT : NICKEL PLATED OVER ALL
  - 2-3. SETSCREW : NICKEL PLATED OVER ALL
  - 2-4. "T" HOLDER: NICKEL PLATED OVER ALL
  - 2-5. SHELL : NICKEL PLATED OVER ALL
3. ELECTRICAL SPECIFICATION :
  - 3-1. Rated current : 5A
  - 3-2. Rated voltage : 250V
4. ENVIRONMENTAL :
  - 4-1. Operation Temperature : -40℃~85℃

TABLE A

DI-03M2-17-11	DI-04M2-09	DI-05M2-26-11	DI-05M2-25-11	DI-06M2-12-11	DI-07M2-25-11	DI-08M2-06

DRAWN	Ku Chou	APP'D	Emily Suen	UNIT	mm	TOLERANCE		广东科斯达电子科技有限公司 GUANG DONG KE SI DA ELECTRONIC TECHNOLOGY CO., LTD.	TITLE	270° MALE DIN CABLE PLUG			SHEET	1/2
CHK'D	Emily Suen			SCALE	1:1	.x ±0.25 .xx ±0.10 .xxx ±0.05 .xxxx ±0.03 ANGULA ±1°			PART NO.	SEE TABLE A	DWG NO.	QC5608	VERSION	A