

CUSTOMER DRAWING

REV.	DESCRIPTION	APPVL. BY	DATE	ECN NO.
A	RELEASE	Fido Weng	05/10/23"	
B				
C				

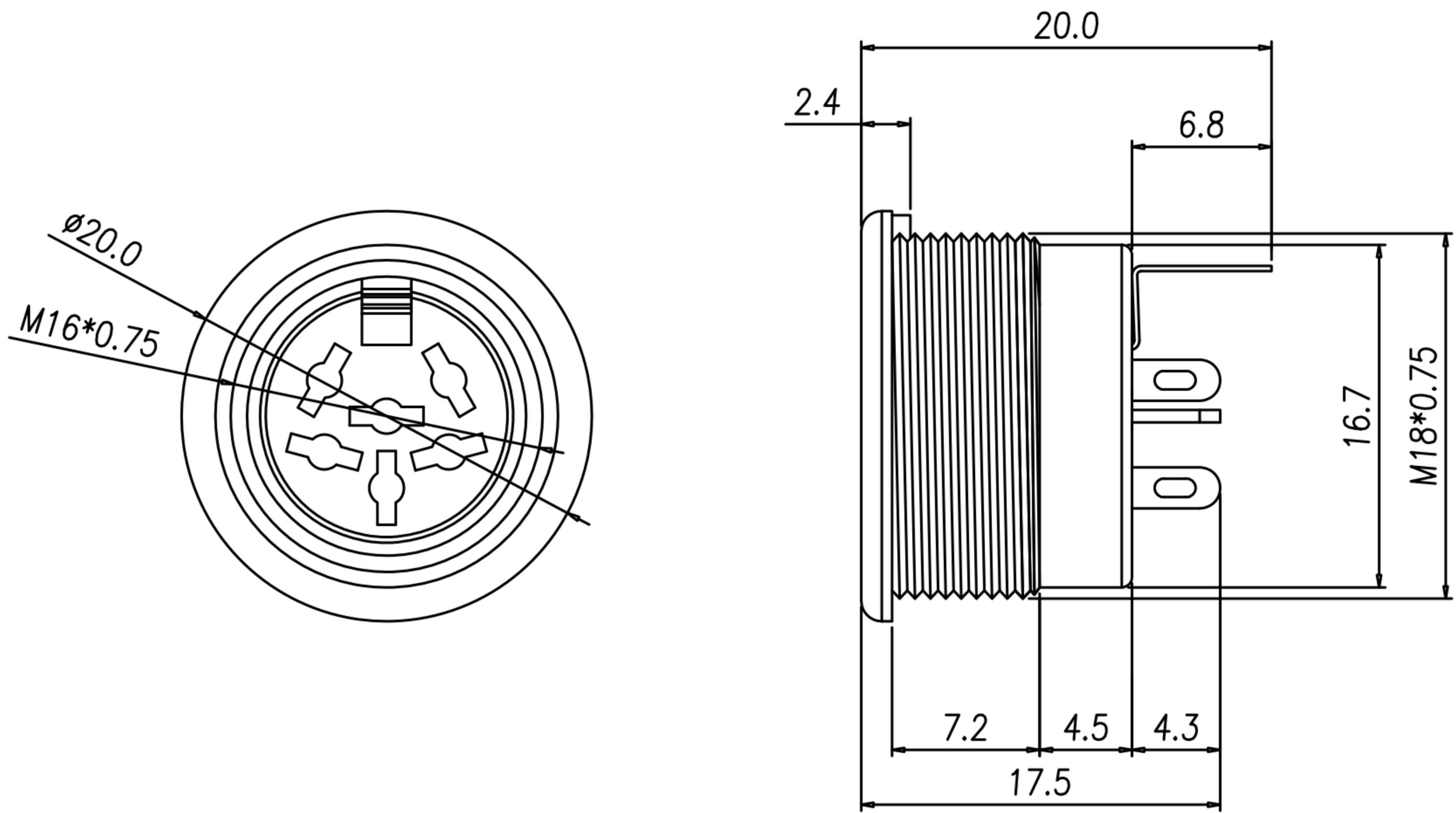
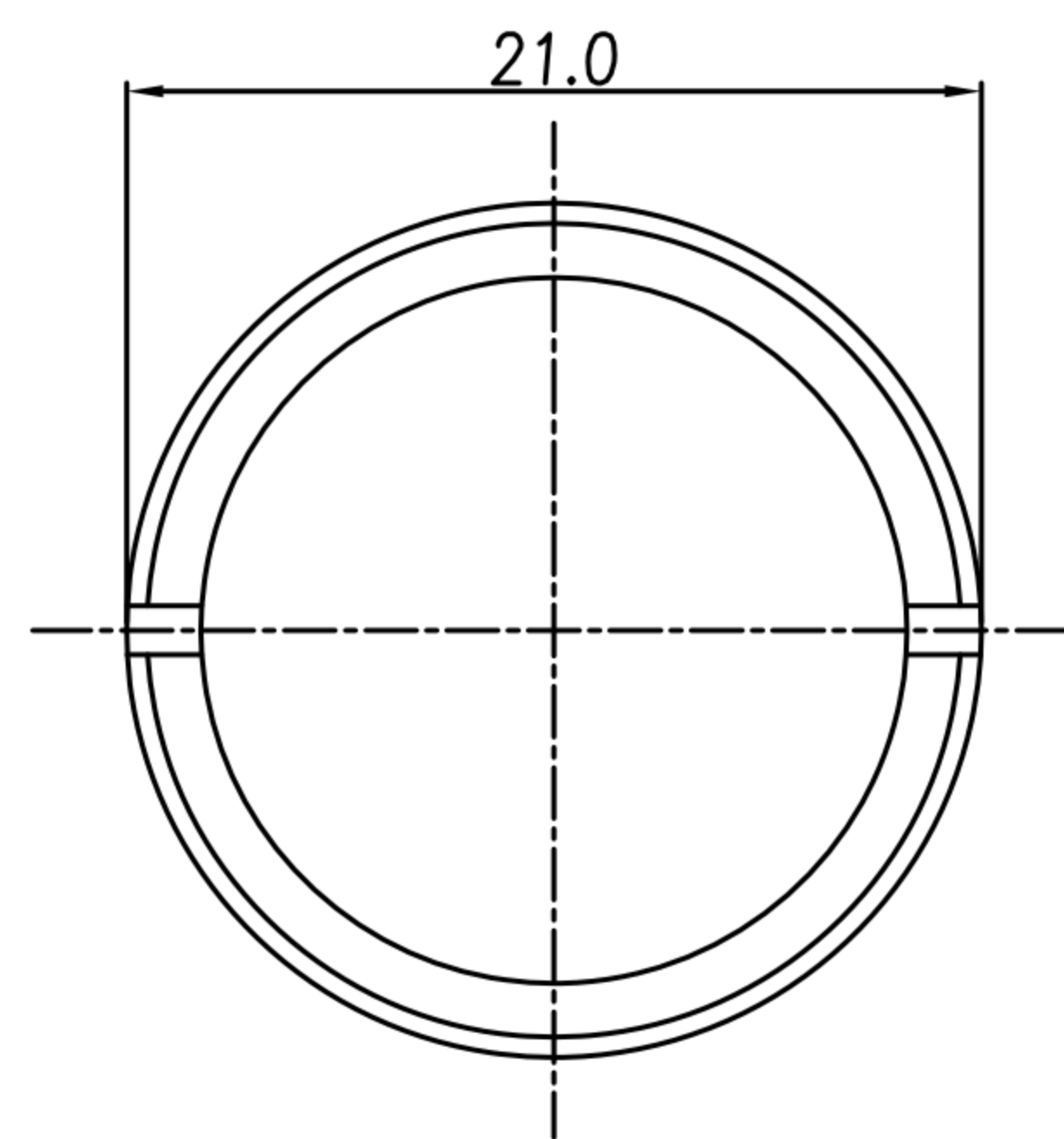
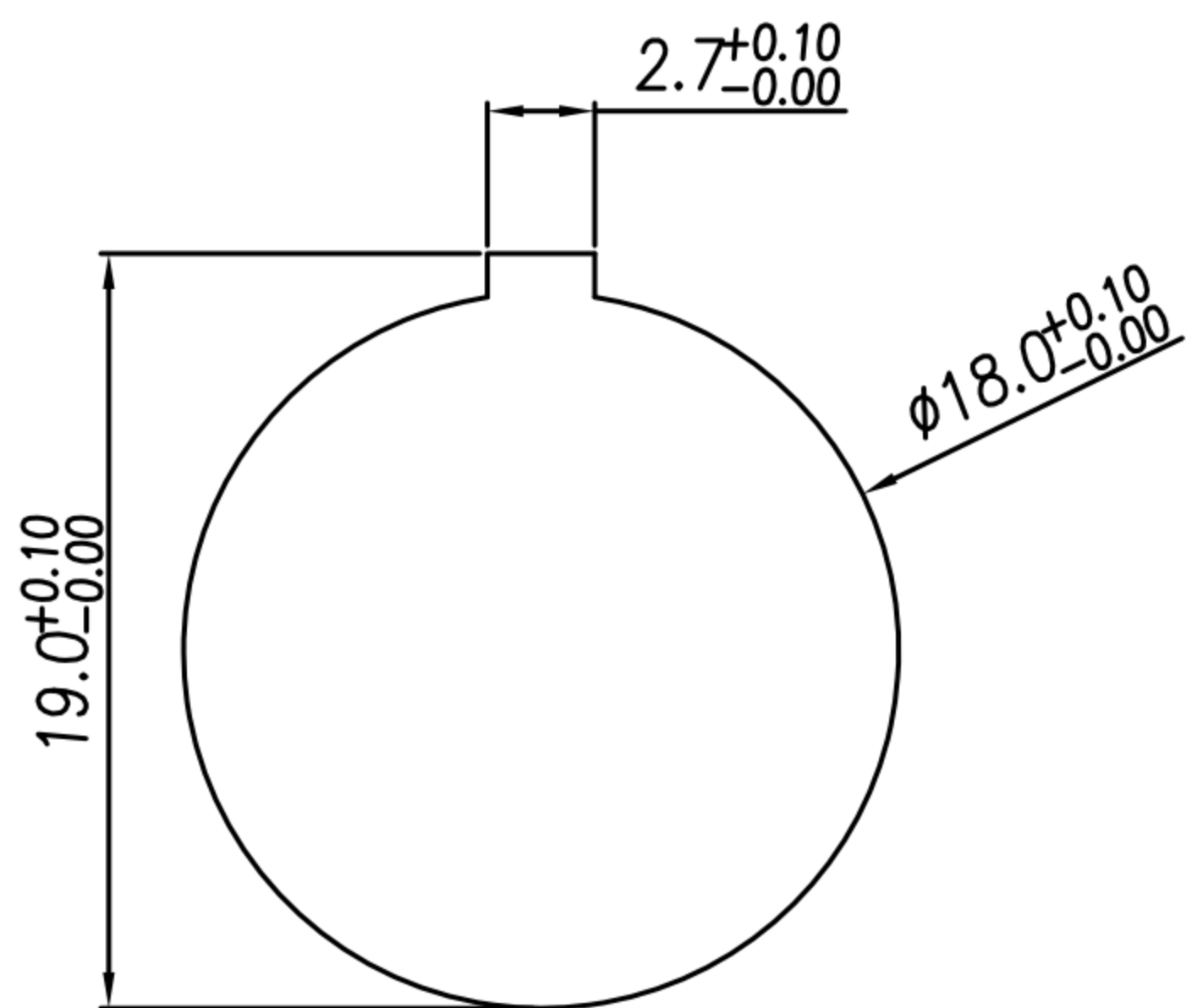
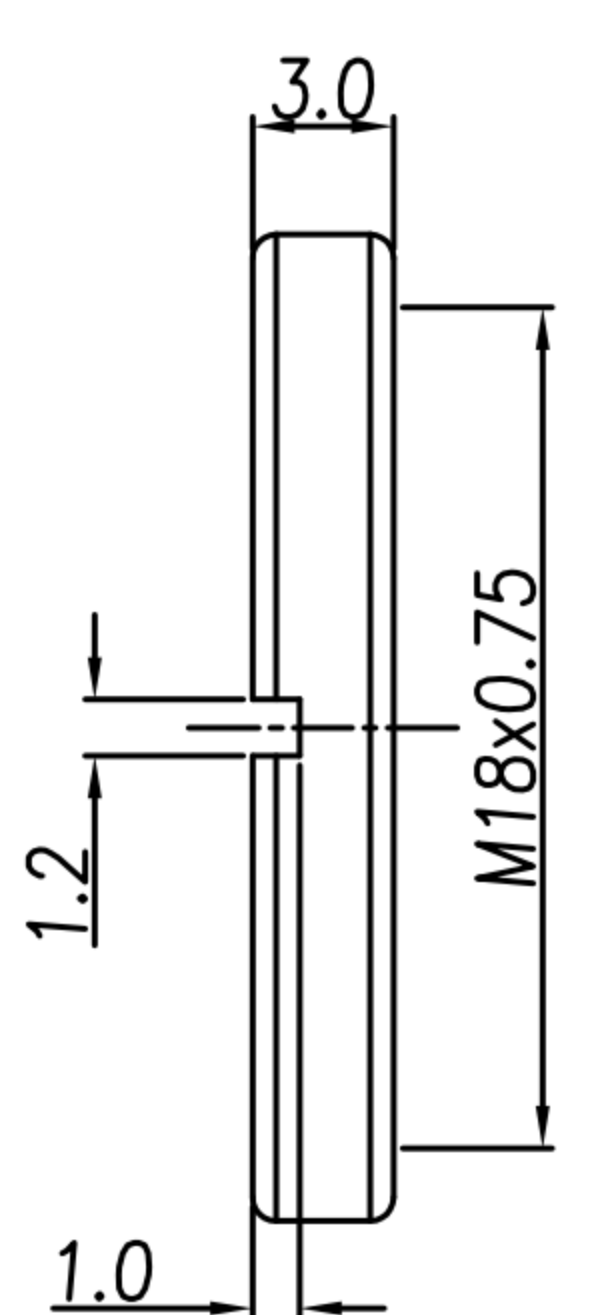

TABLE A

3PIN	4PIN	5PIN(05-A)
DI-03F2-18-11	DI-04F2-25-11	DI-05F2-29-11
5PIN(05-B)	6PIN	
DI-05F2-28-11	DI-06F2-30-11	
7PIN	8PIN	
DI-07F2-27-11	DI-08F2-21-11	



NUT



RECOMMEND PANEL CUT-OUT

NOTE

- MATERIAL :
 - HOUSING : PA66 UL94V-0 ; COLOR : BLACK
 - CONTACT : BRASS.
 - SHELL : PA66 UL94V-0 ; COLOR : GREY
 - NUT : BRASS
 - GROUND : PHOSPHOR BRONZE
- FINISH :
 - CONTACT : TIN PLATED.
 - NUT : NICKEL PLATED.
 - GROUND : NICKEL PLATED.
- ELECTRICAL SPECIFICATION :
 - Rated current : 5A
 - Rated Voltage : 250V
- Environmental :
 - Operation Temperature : -25°C~85°C

DRAW	Mark Kao	APPVL	Emily Suen	UNIT	mm	TOLERANCE			广东科斯达电子科技有限公司 GUANG DONG KE SI DA ELECTRONIC TECHNOLOGY CO., LTD.	TITLE	DIN M16X0.75 (F) 後鎖螺絲式(塑膠外殼/魚叉式端子)			SHEET	1
CHECK	Emily Suen			SCALE	1:1	.x ±0.20 .xx ±0.10 .xxx ±0.05 .xxxx ±0.03 ANGULA ±1°				PART NO.	SEE TABLE A	DWG NO.	QC10891	VERSION	