

CUSTOMER DRAWING

REV.	DESCRIPTION	APPROVED BY	DATE	ECN NO.
A	RELEASE	Emily Suen	02/09/19*	
B				
C				

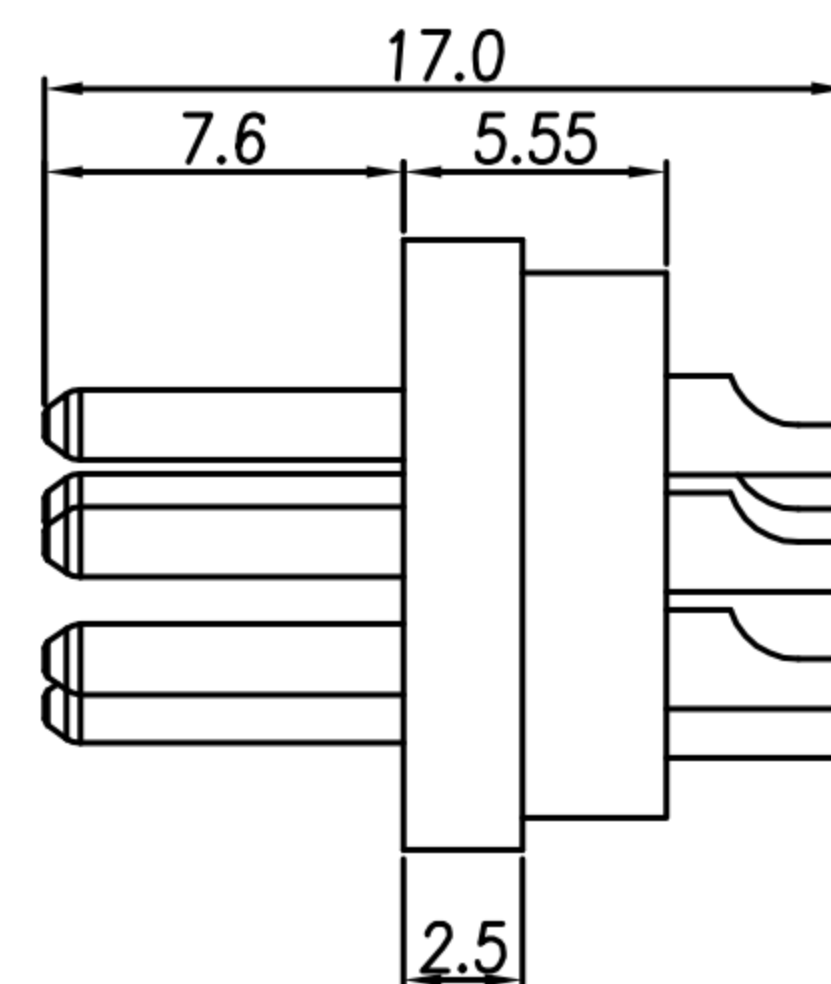

3P~8PIN尺寸

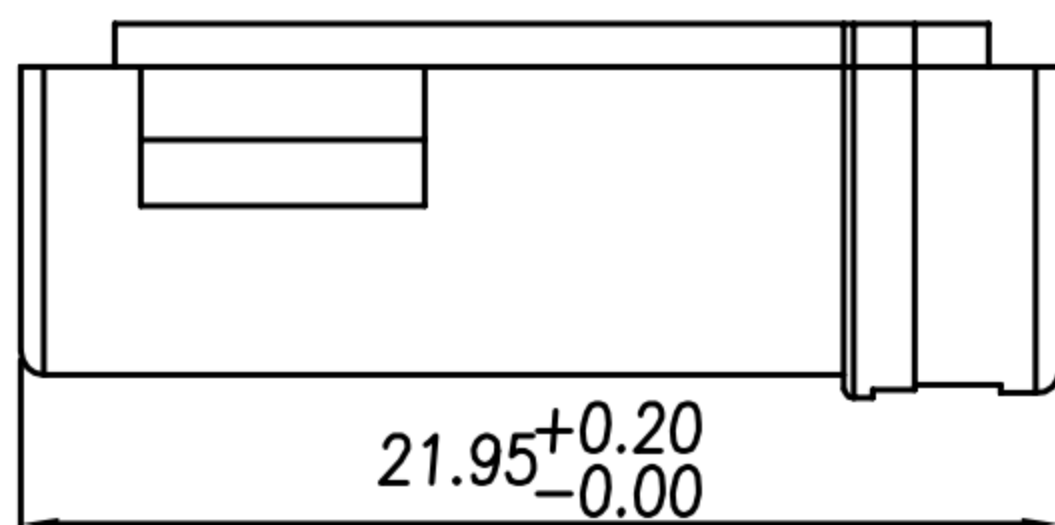
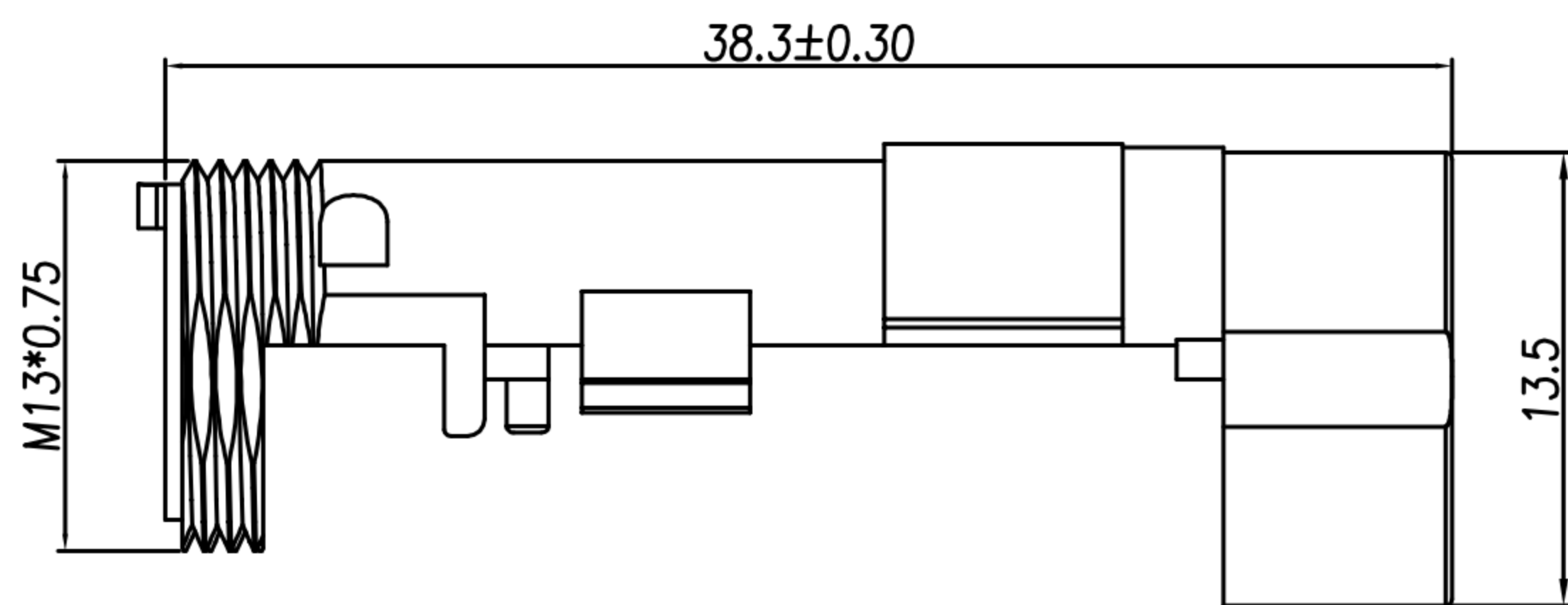
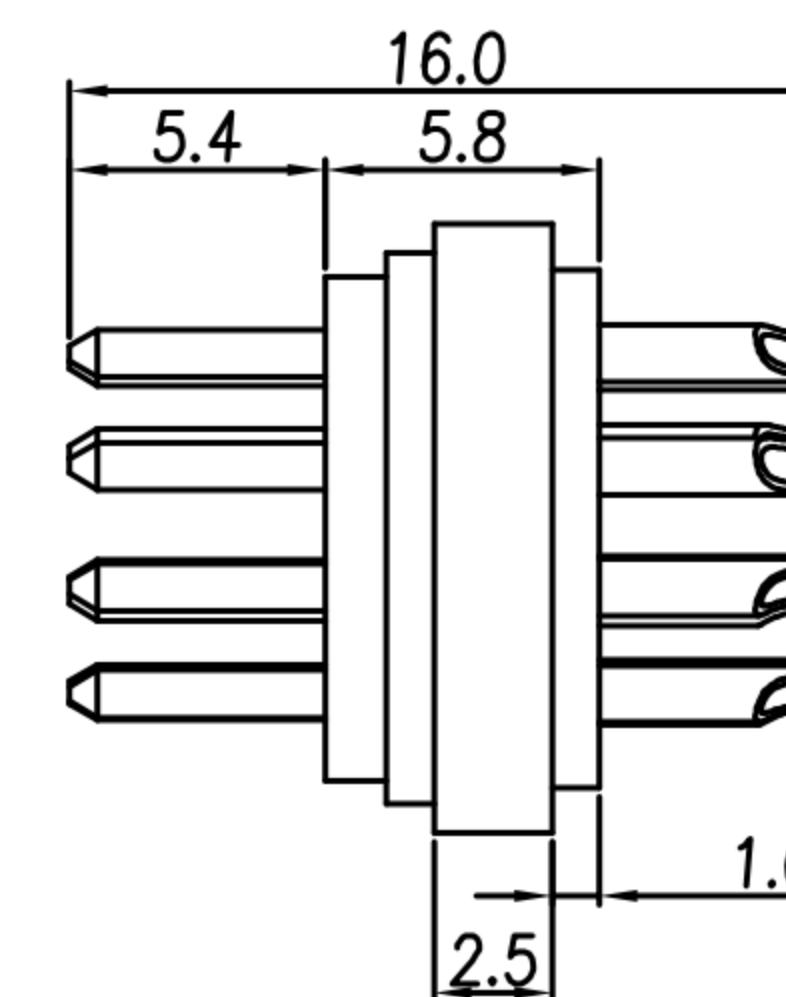

12PIN尺寸

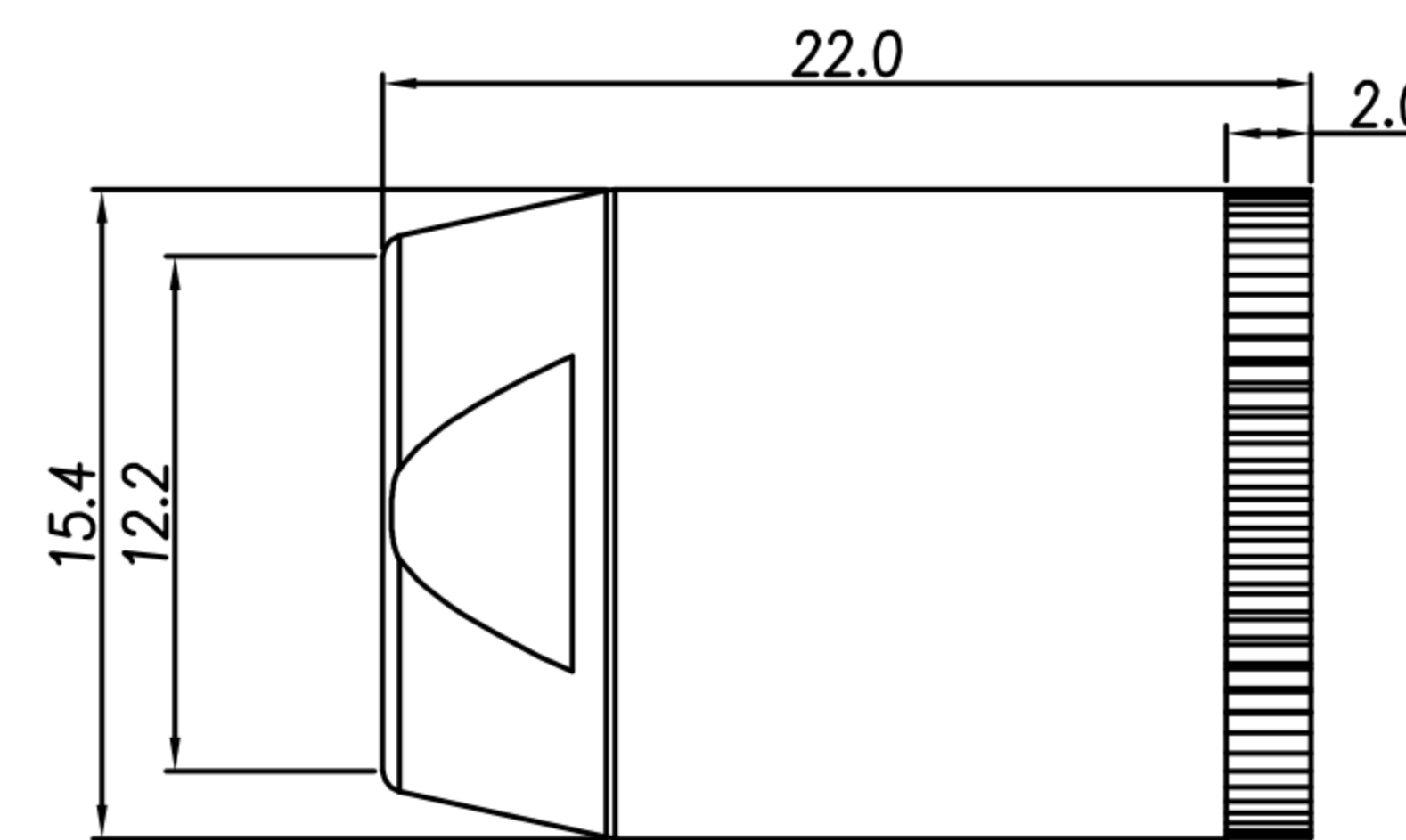
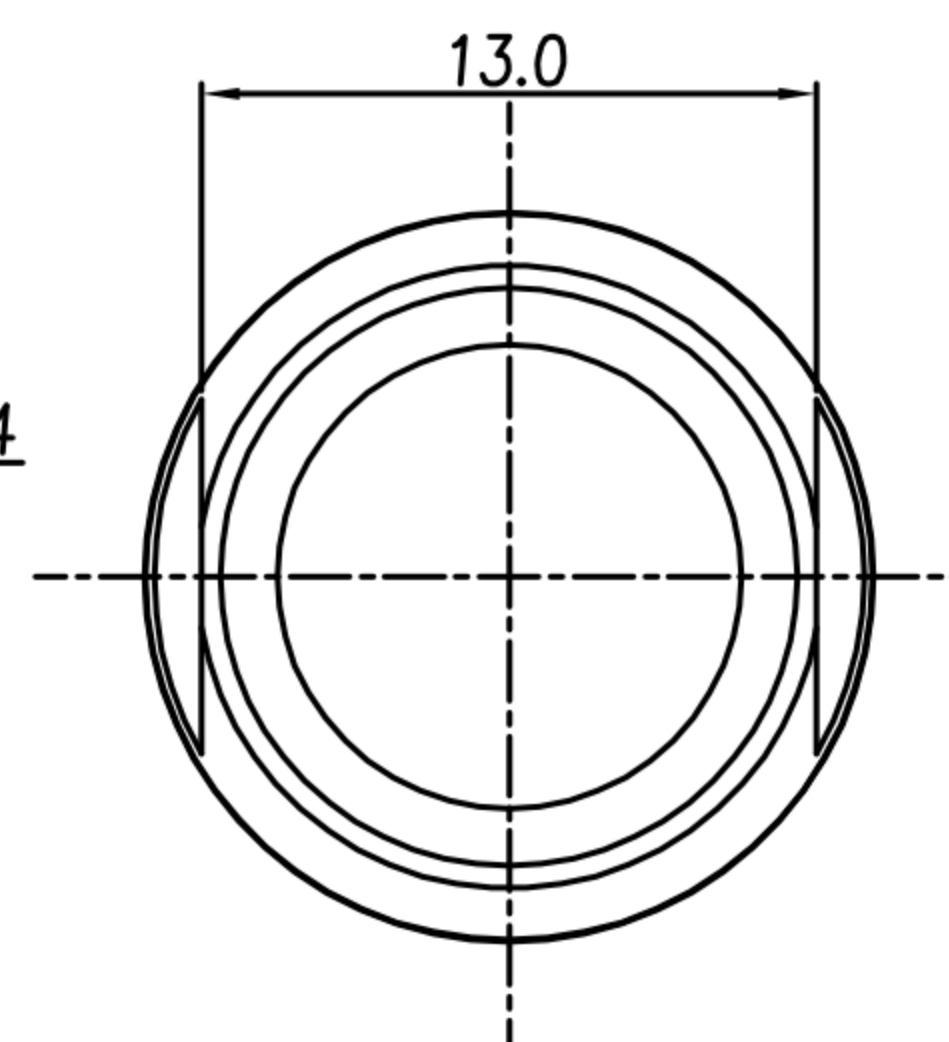
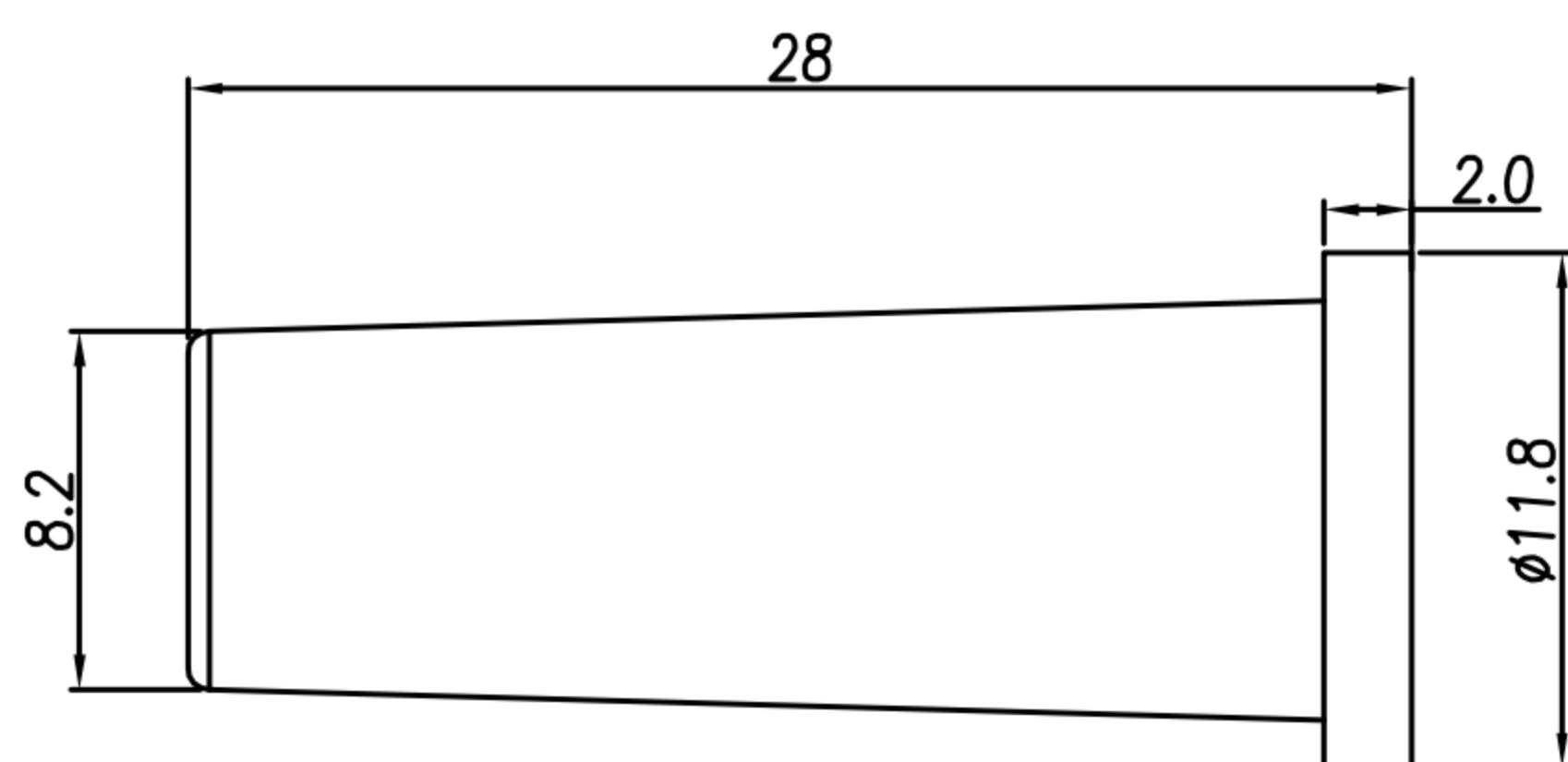
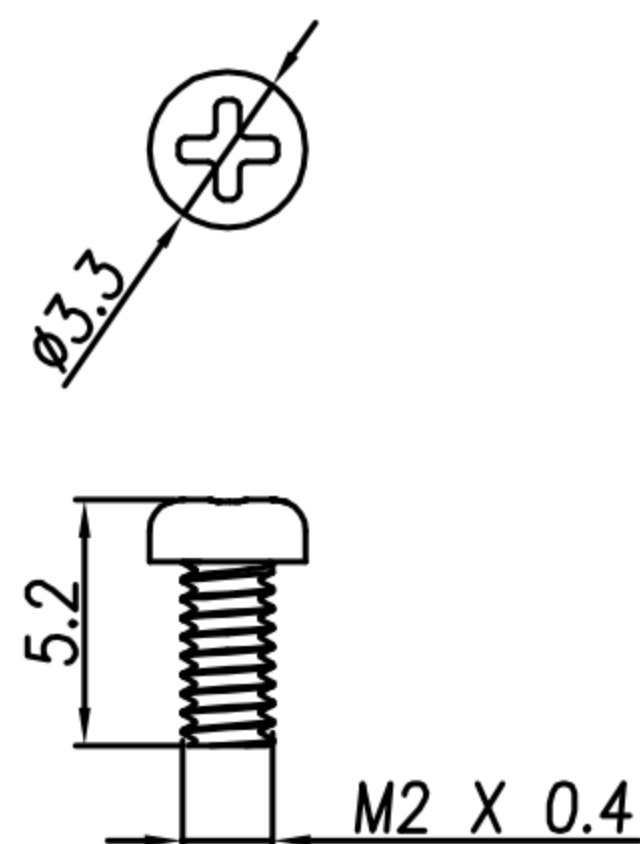
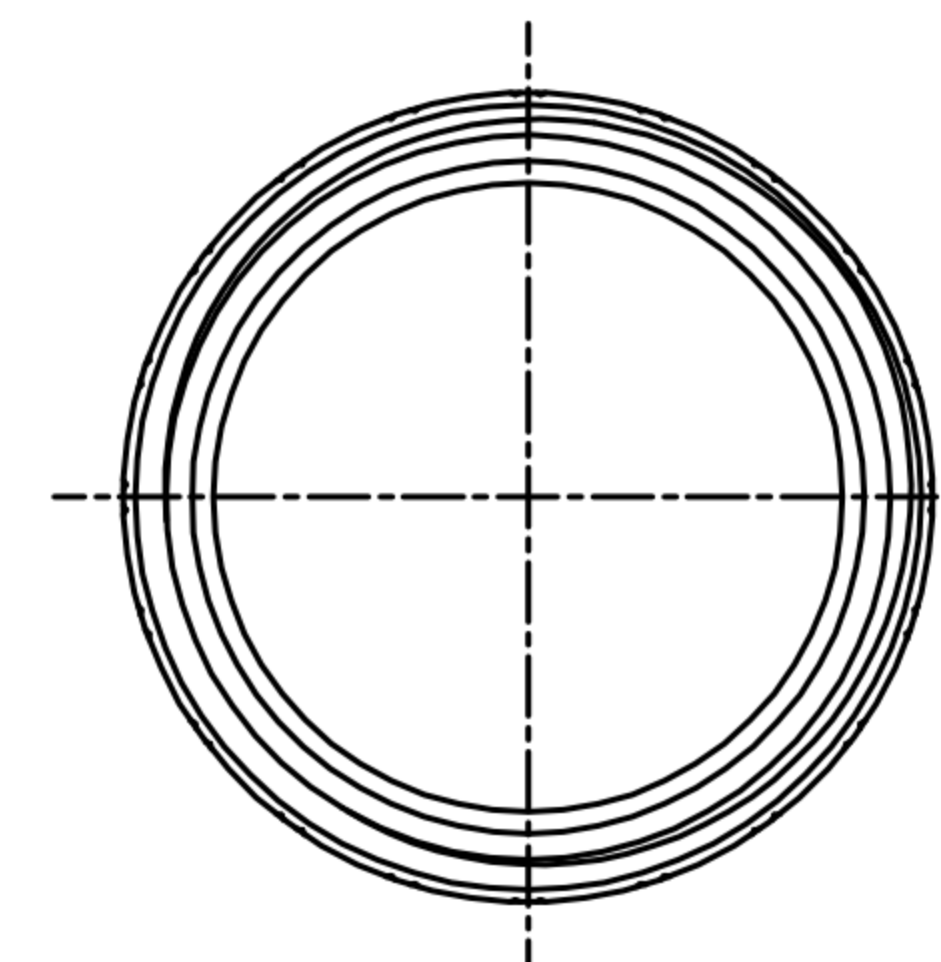
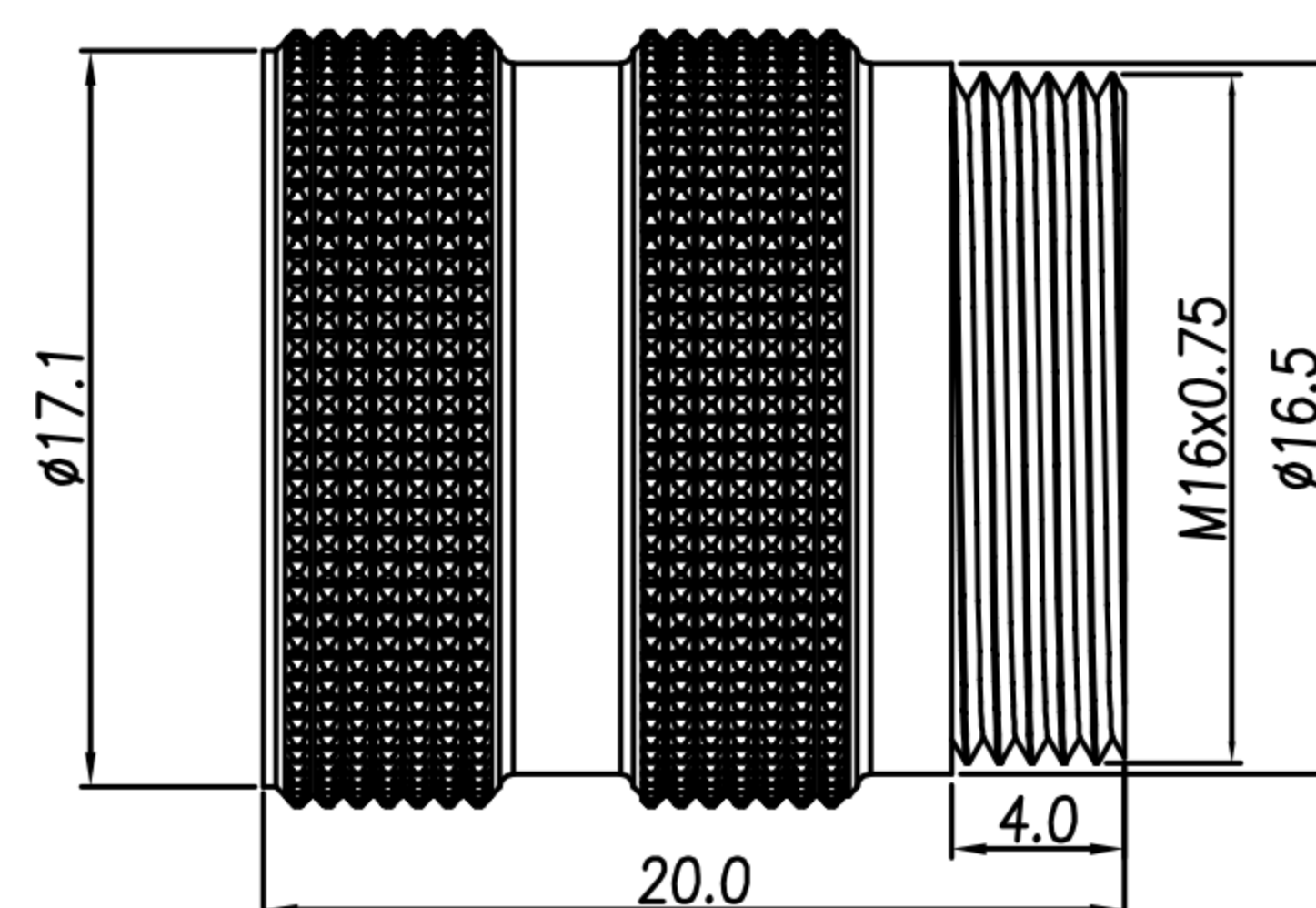
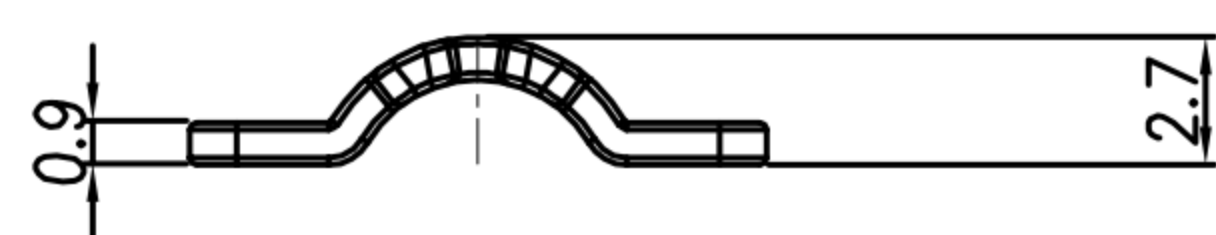
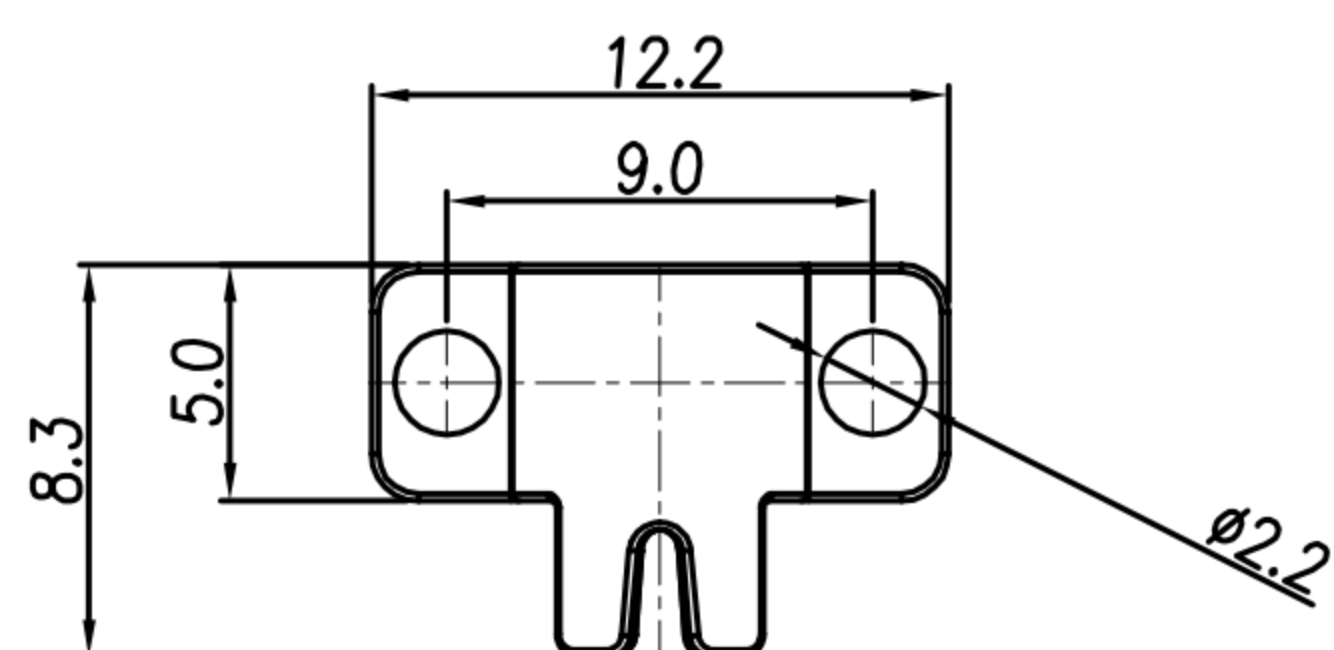
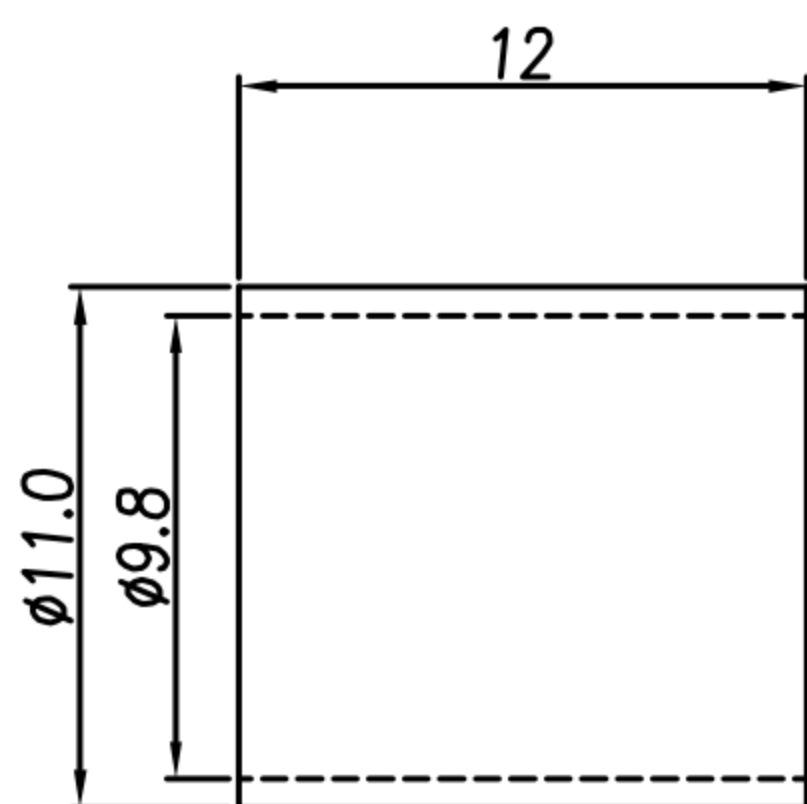

DRAWN	LED	APP'D	Ku Chou	UNIT	mm	TOLERANCE		广东科斯达电子科技有限公司 GUANG DONG KE SI DA ELECTRONIC TECHNOLOGY CO., LTD.	TITLE	DIN (M) Assembly type(端子金)(OD6mm)			SHEET	3/3
CHK'D	Emily Suen			SCALE	1:1	.x ±0.20 .xx ±0.10 .xxx ±0.05 .xxxx ±0.03 ANGULA ±1°			PART NO.	SEE TABLE A	DWG NO.	QC9388	VERSION	A

CUSTOMER DRAWING

REV.	DESCRIPTION	APPROVED BY	DATE	ECN NO.
△A	RELEASE	Emily Suen	02/09/19*	
△B				
△C				

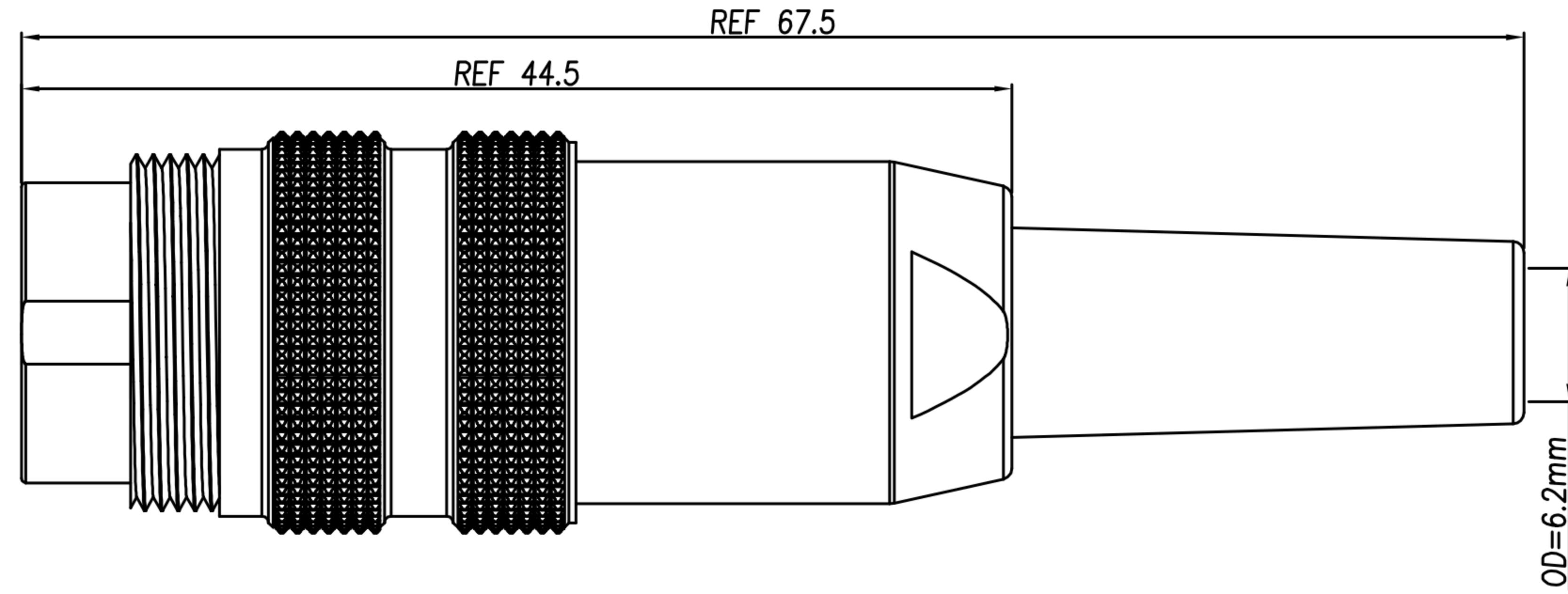
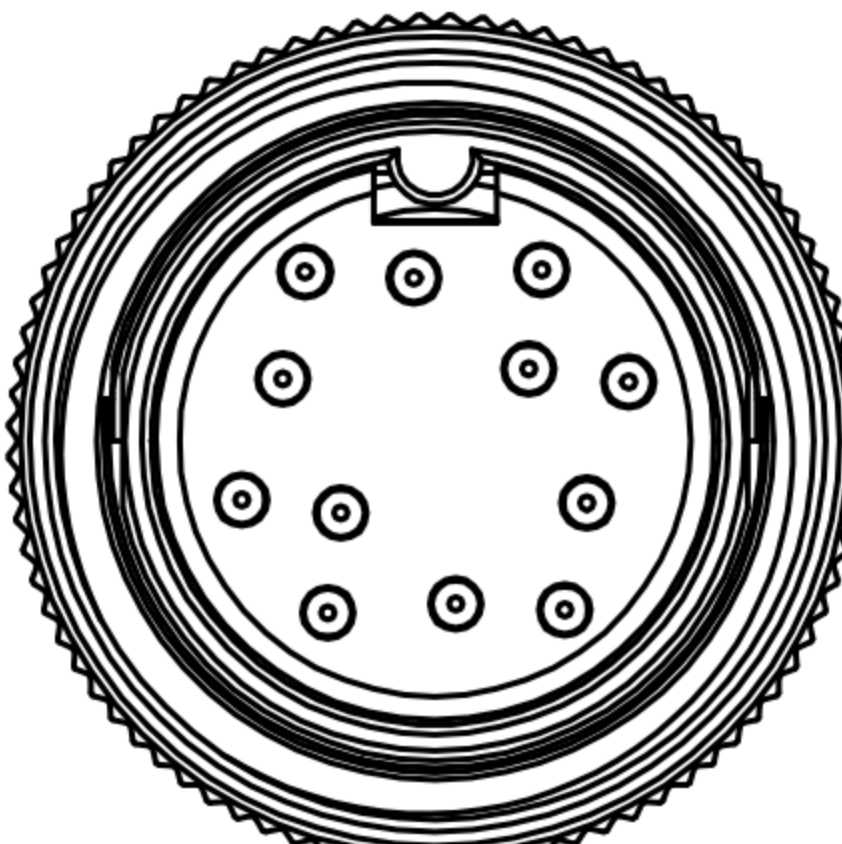

- MATERIAL :**
 - 1-1. HOUSING : NYLON UL94V-0 ; COLOR : BLACK
 - 1-2. CONTACT :BRASS
 - 1-3. CAP : ZINC ALLOY
 - 1-4. CLAMPS BODY : ZINC ALLOY
 - 1-5. SCREW : SPCC
 - 1-6. CLAMPS : ZINC ALLOY
 - 1-7. ISOLATION : PVC
 - 1-8. COAT : BRASS
 - 1-9. BACK BODY : NYLON+GF15% UL94V-0 ;COLOR: BLACK
 - 1-10. SR : PVC
- FINISH :**
 - 2-1. CONTACT : GOLD FLASH MICRO INCHES MIN.
 - 2-2. CAP : NICKEL PLATED
 - 2-3. CLAMPS : NICKEL PLATED
 - 2-4. CLAMPS BODY : NICKEL PLATED
 - 2-5. SCREW : NICKEL PLATED
 - 2-6. COAT : NICKEL PLATED
- ELECTRICAL SPECIFICATION :**
 - 3-1. Rated current : 3PIN~8PIN 5A ; 12PIN 3A
 - 3-2. Rated Voltage : 3PIN~8PIN 250V ;12PIN 60V
 - 3-3. Water proof : IP40
- Environmental :**
 - 4-1. Operation Temperature : -20 ℃~85℃

DI-03M2-13-11	DI-04M2-22-11	DI-05M2-19-11	DI-05M2-21-11	DI-06M2-20-11	DI-07M2-22-11	DI-07M2-19-11	DI-08M2-21-11	DI-12M2-16-11

DRAWN	LED	APP'D	Ku Chou	UNIT	mm	TOLERANCE				TITLE	DIN (M) Assembly type(端子表)(OD6mm)			SHEET
CHK'D	Emily Suen			SCALE	1:1					PART NO.	SEE TABLE A	DWG NO.	QC9388	VERSION

CUSTOMER DRAWING

REV.	DESCRIPTION	APPROVED BY	DATE	ECN NO.
A	RELEASE	Emily Suen	02/09/19*	
B				
C				

ASSEMBLY INSTRUCTION

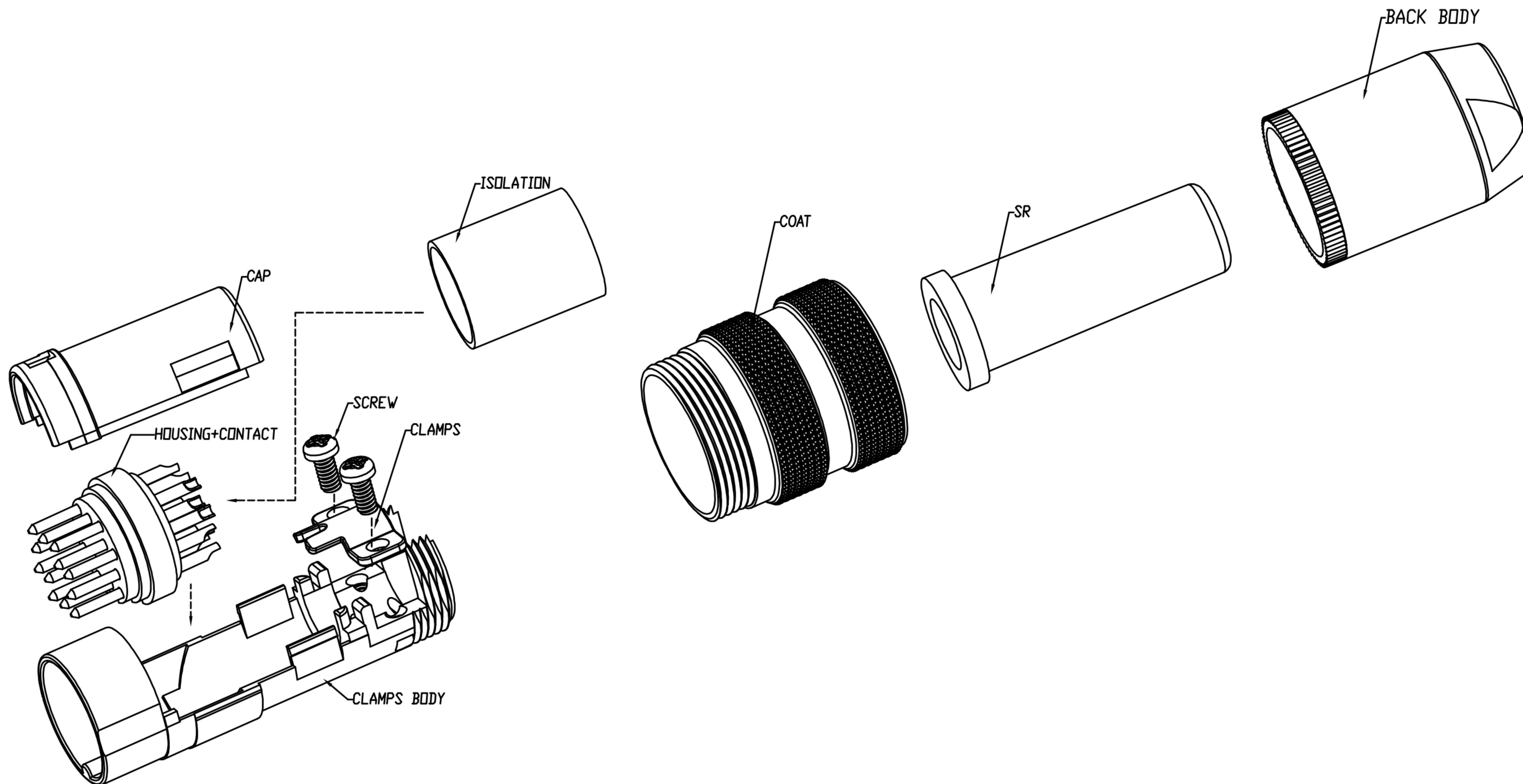

DRAWN	LED	APP'D	Ku Chou	UNIT	mm	TOLERANCE		广东科斯达电子科技有限公司 GUANG DONG KE SI DA ELECTRONIC TECHNOLOGY CO., LTD.	TITLE	DIN (M) Assembly type(端子夹金)(OD6mm)			SHEET	2
CHK'D	Emily Suen			SCALE	1:1	.x ±0.20 .xx ±0.10 .xxx ±0.05 .xxxx ±0.03 ANGULA ±1°			PART NO.	SEE TABLE A	DWG NO.	QC9388	VERSION	A