

CUSTOMER DRAWING

| REV. | DESCRIPTION | APPROVED BY | DATE      | ECN NO. |
|------|-------------|-------------|-----------|---------|
| A    | RELEASE     | Emily Suen  | 02/09/19* |         |
| B    |             |             |           |         |
| C    |             |             |           |         |

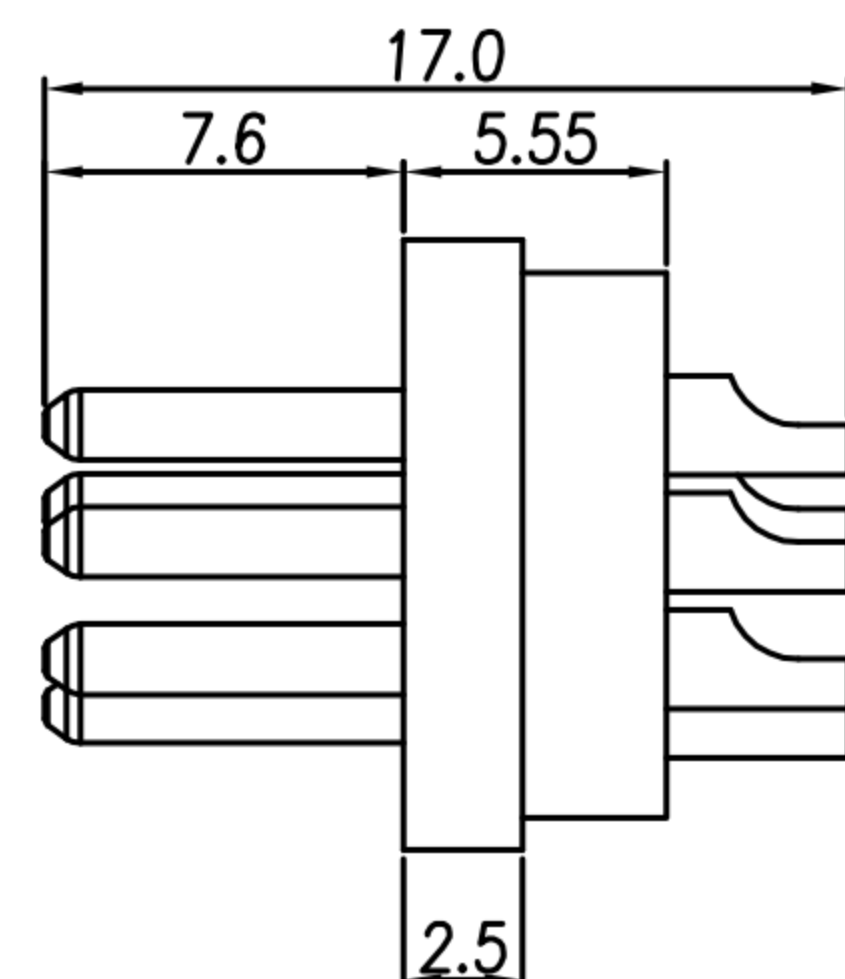

3P~8PIN尺寸

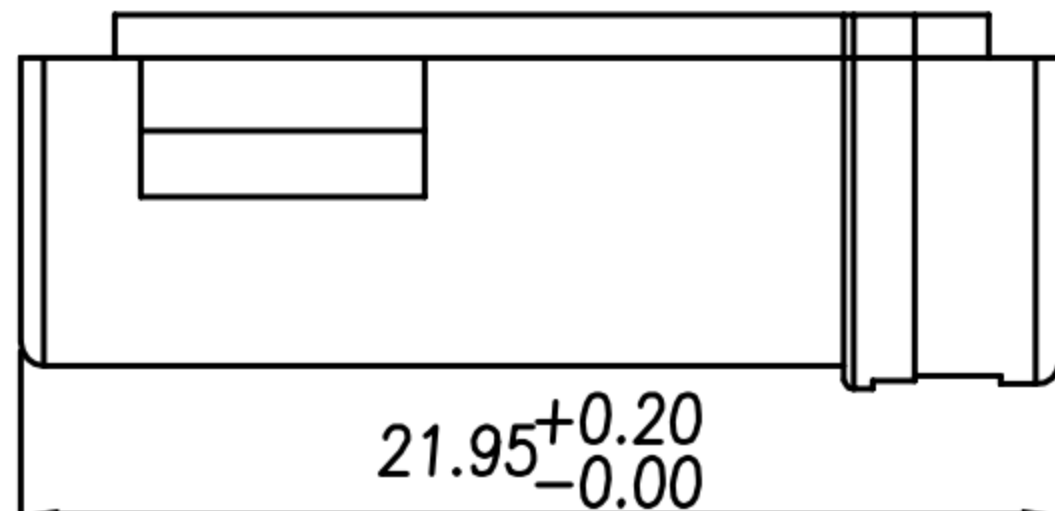
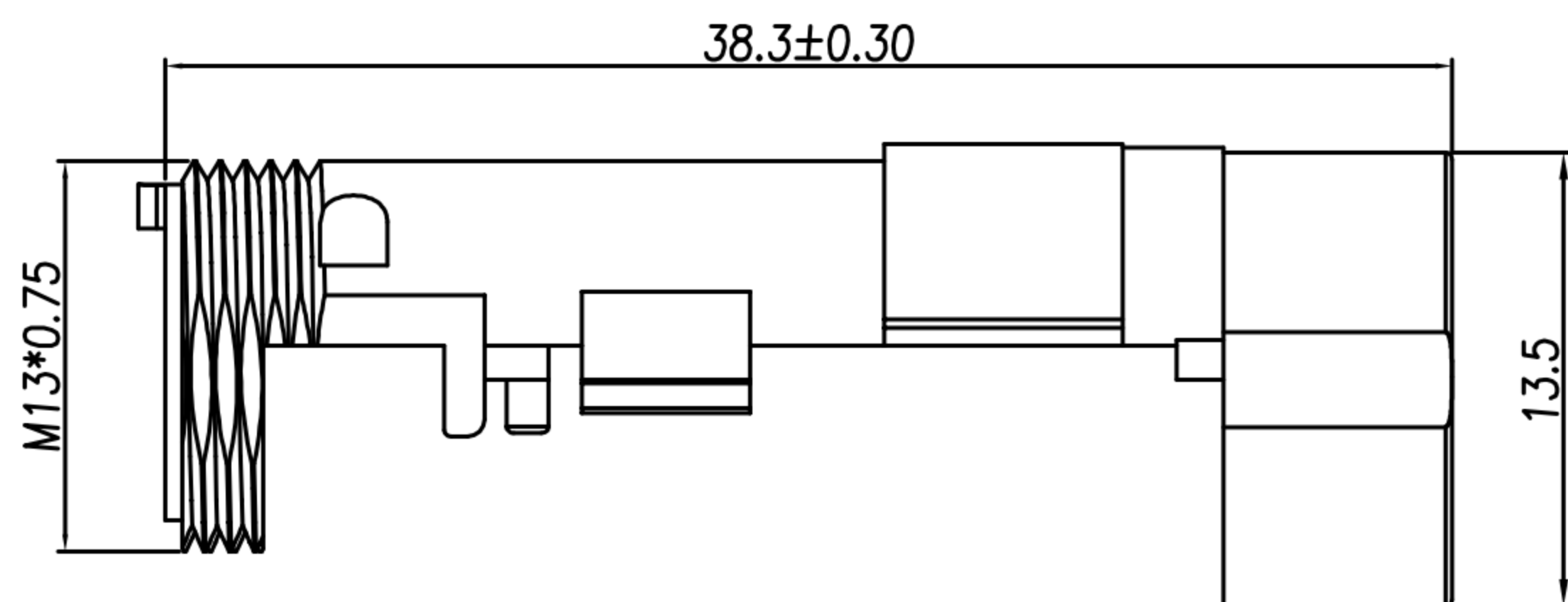
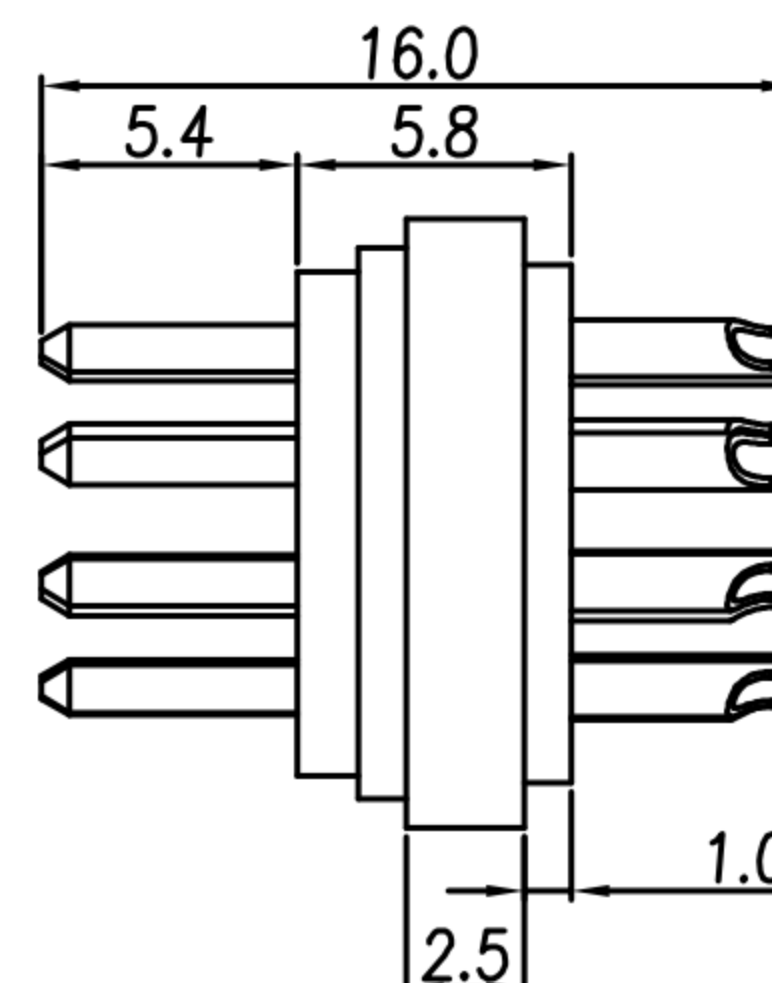

12PIN尺寸

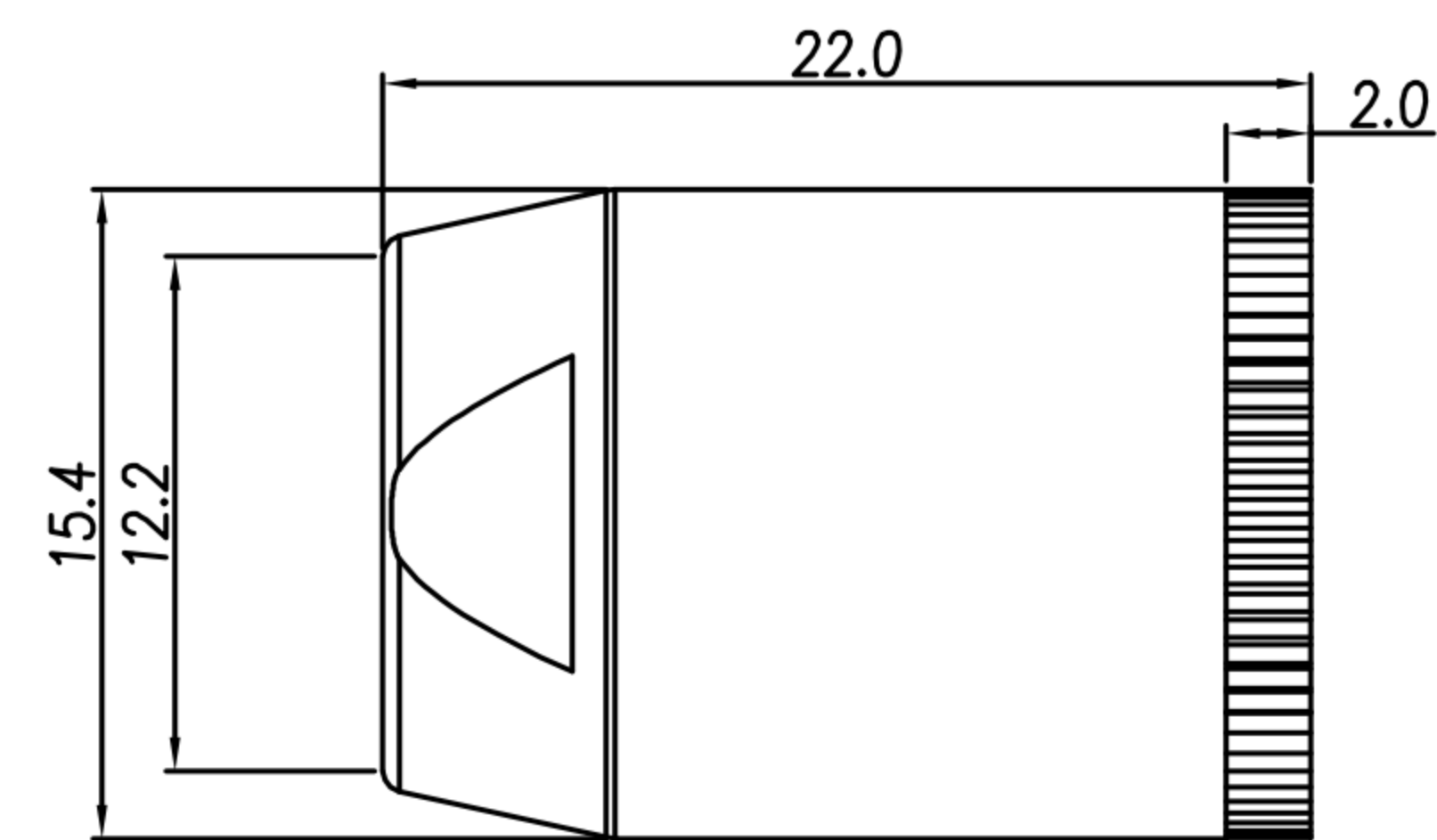
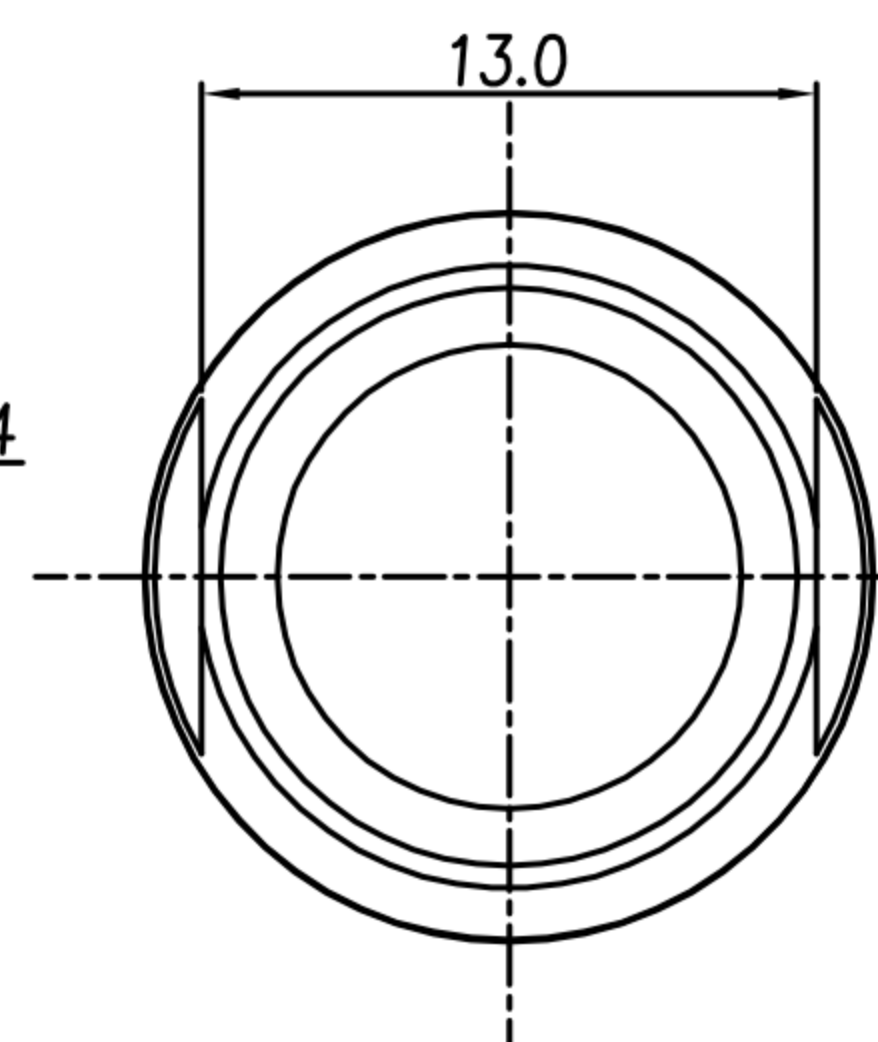
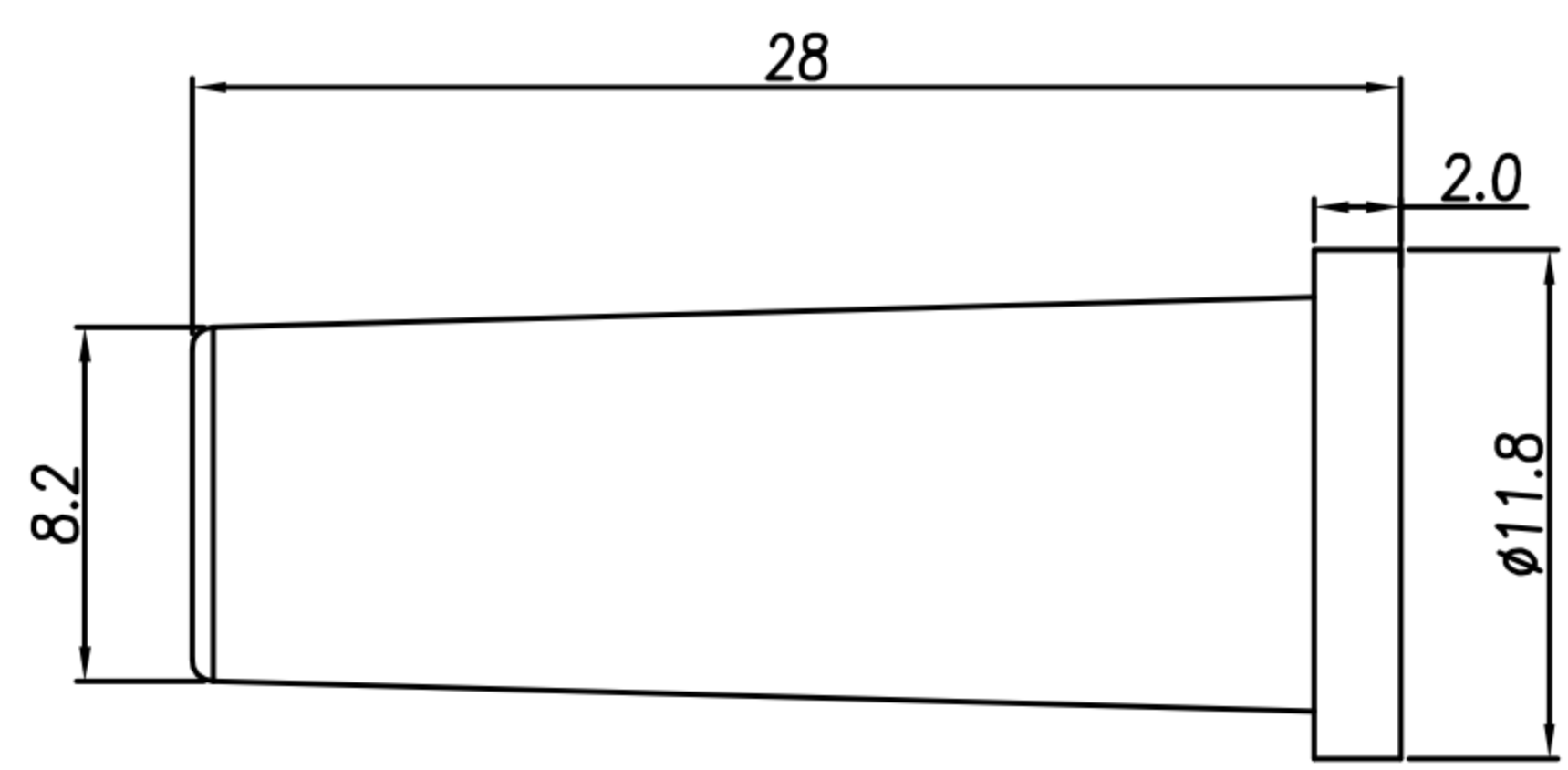
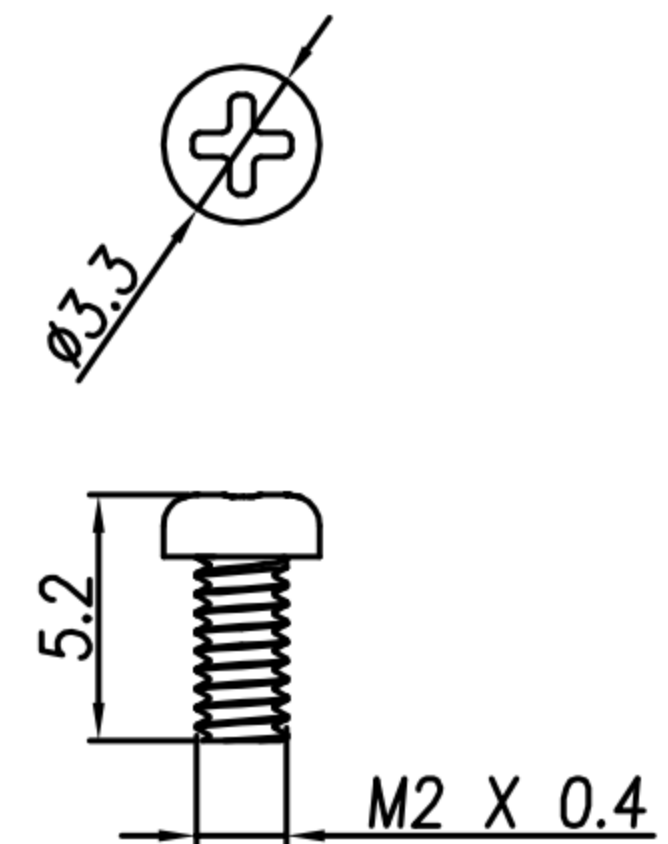
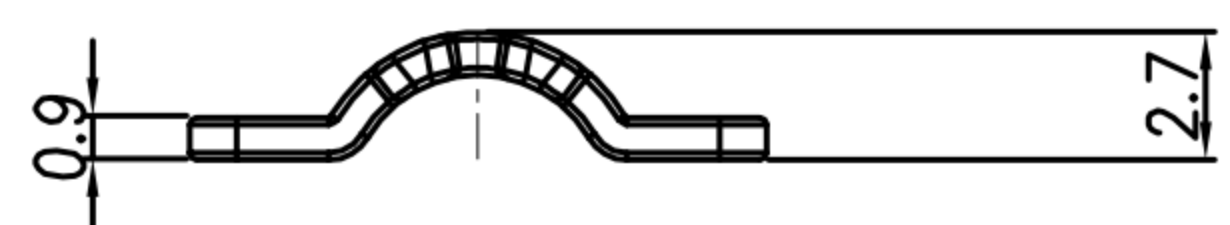
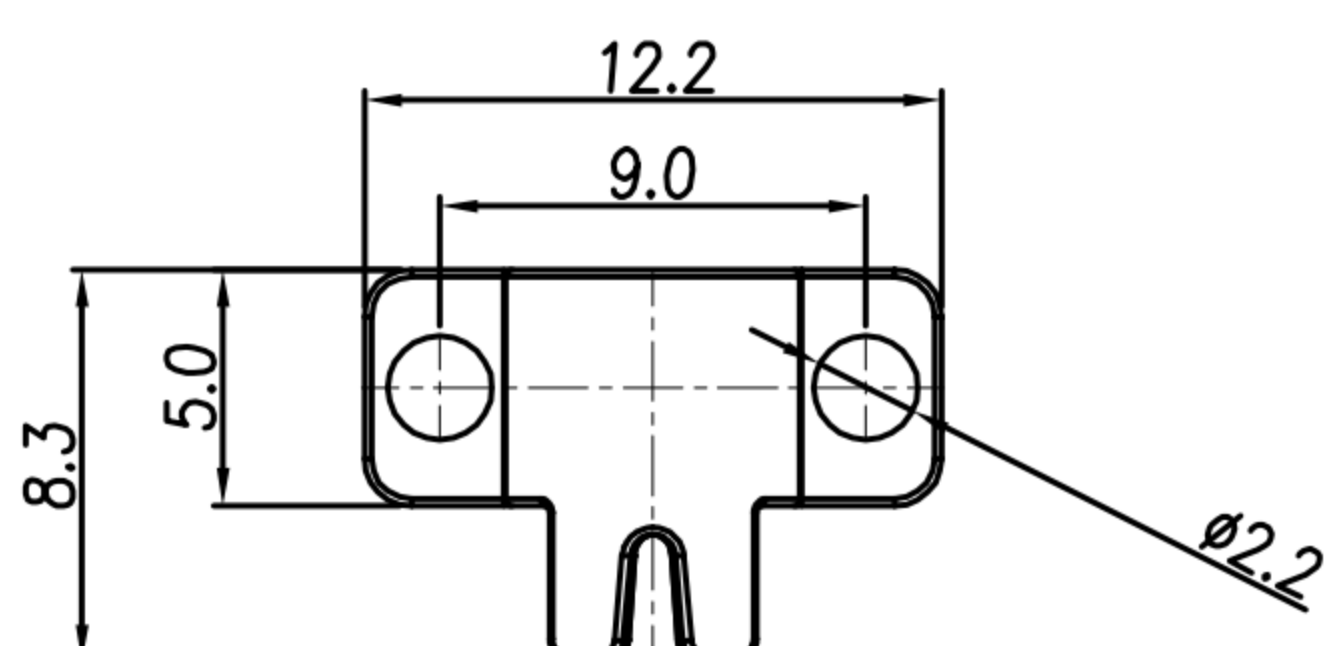
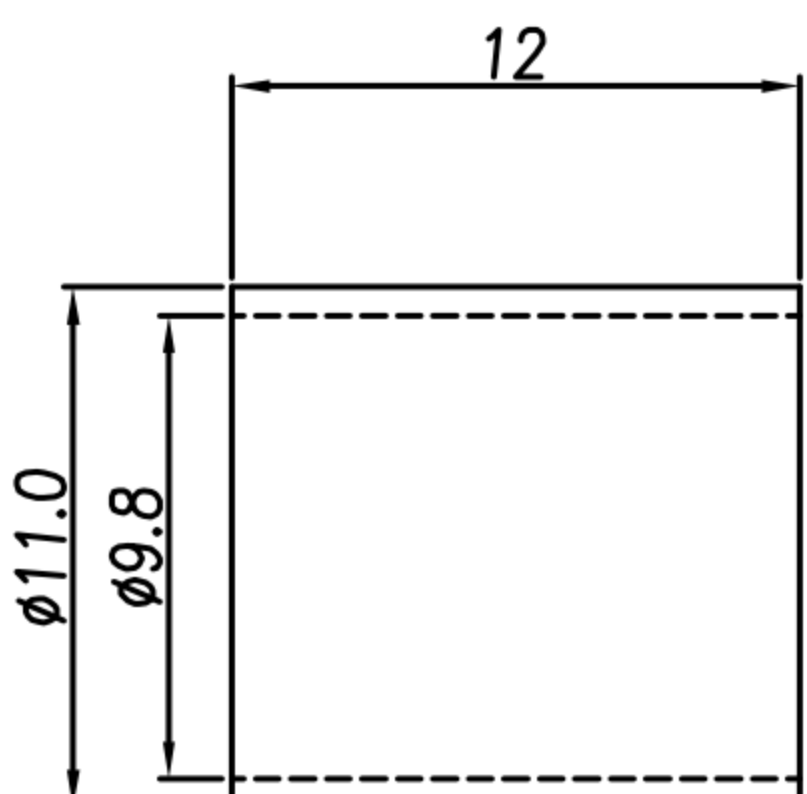
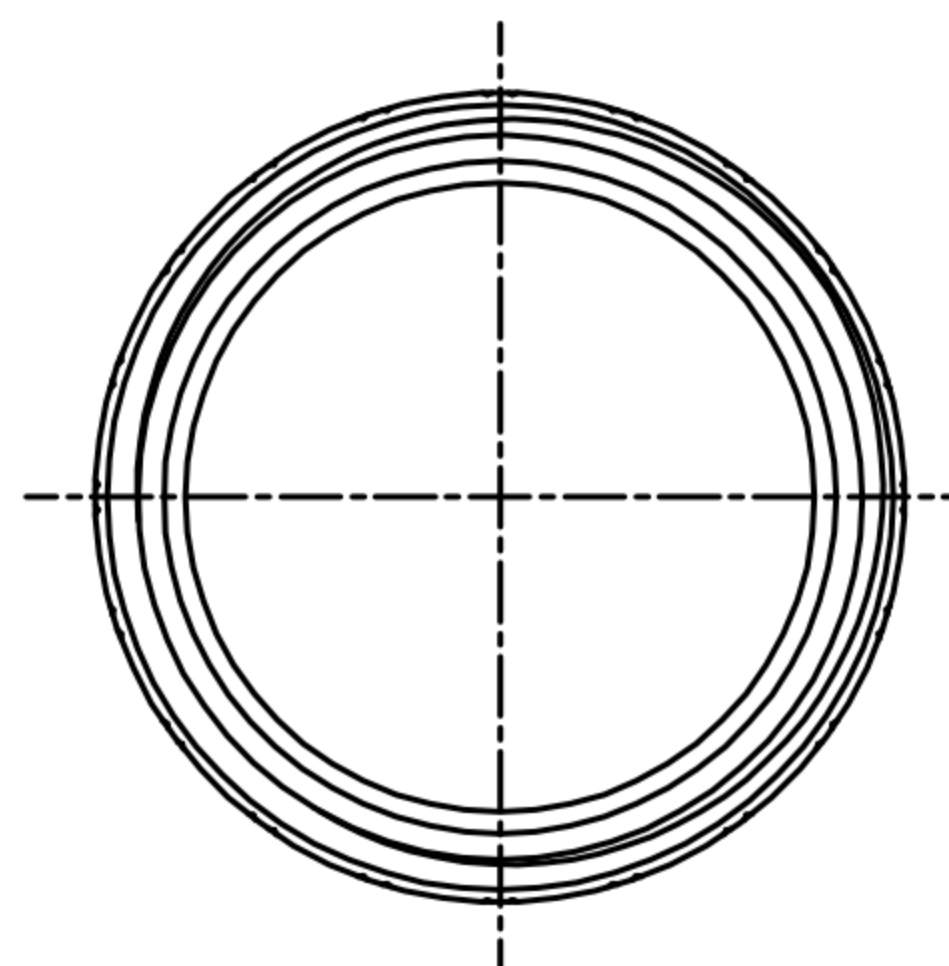
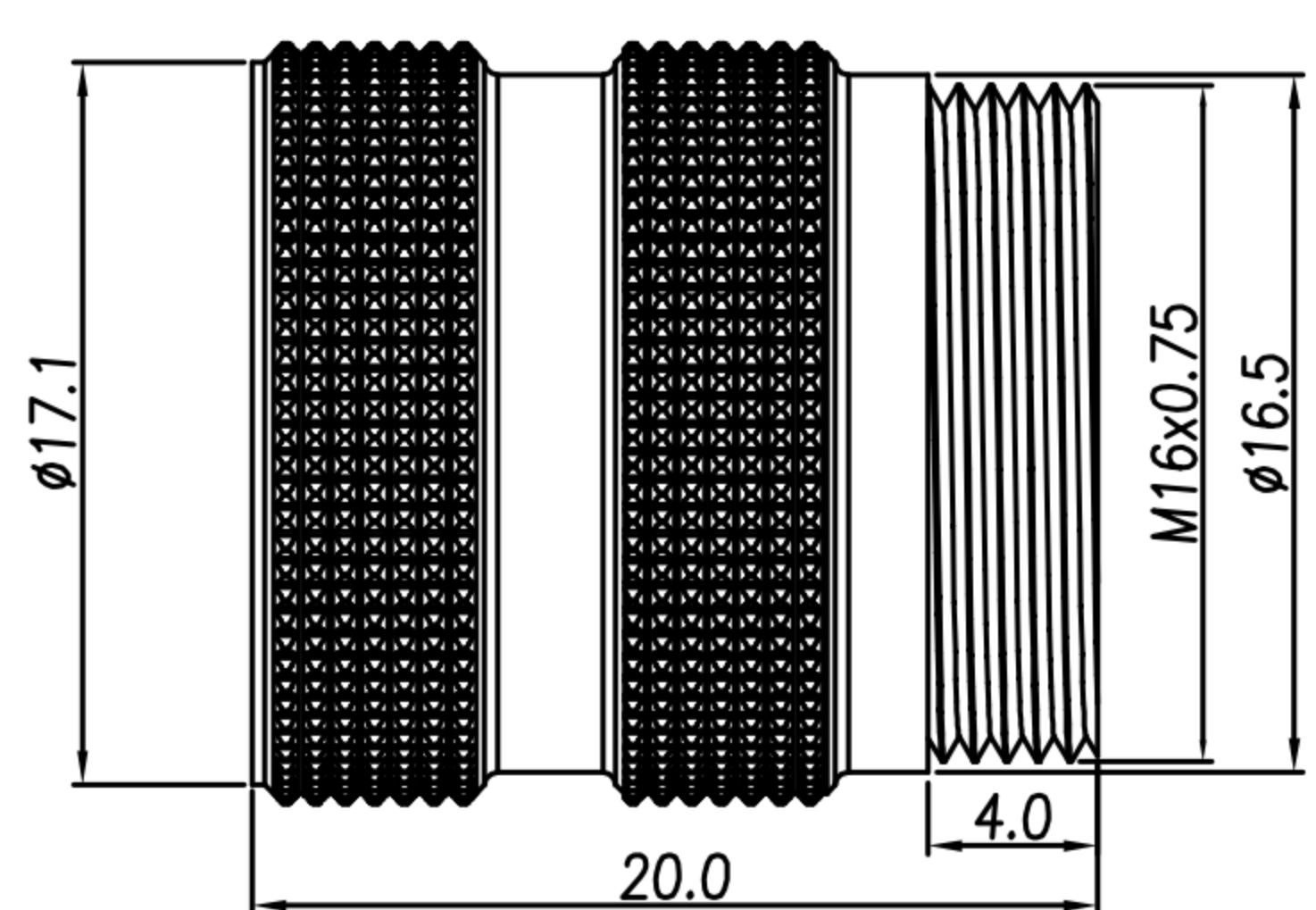

|       |            |       |         |       |     |  |  |          |                                   |         |        |             |
|-------|------------|-------|---------|-------|-----|--|--|----------|-----------------------------------|---------|--------|-------------|
| DRAWN | LED        | APP'D | Ku Chou | UNIT  | mm  | TOLERANCE  |  | TITLE    | DIN (M) Assembly type(端子金)(OD6mm) |         |        | SHEET       |
| CHK'D | Emily Suen |       |         | SCALE | 1:1 | .x ±0.20<br>.xx ±0.10<br>.xxx ±0.05<br>.xxxx ±0.03<br>ANGULA ±1° |  | PART NO. | SEE TABLE A                       | DWG NO. | QC9388 | 3<br>3<br>A |

广东科斯达电子科技有限公司  
GUANG DONG KE SI DA ELECTRONIC TECHNOLOGY CO., LTD.



# CUSTOMER DRAWING

| REV. | DESCRIPTION | APPROVED BY | DATE      | ECN NO. |
|------|-------------|-------------|-----------|---------|
| △A   | RELEASE     | Emily Suen  | 02/09/19* |         |
| △B   |             |             |           |         |
| △C   |             |             |           |         |

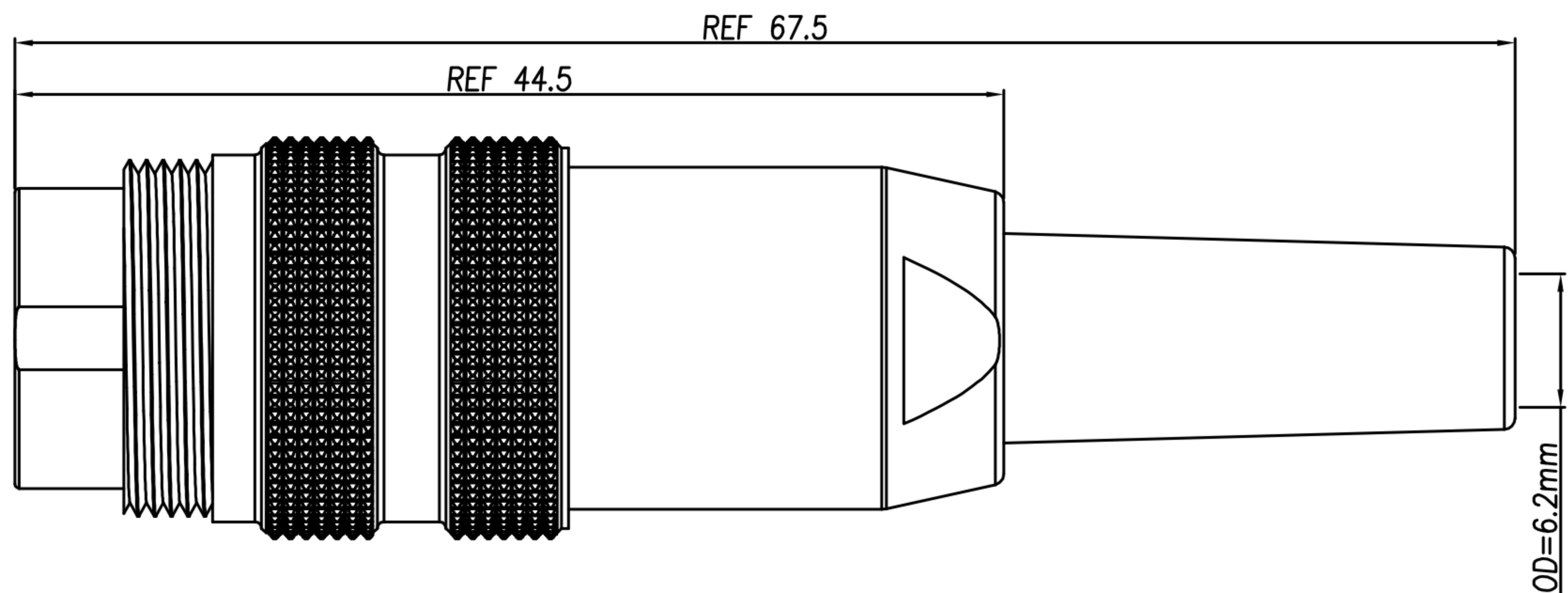
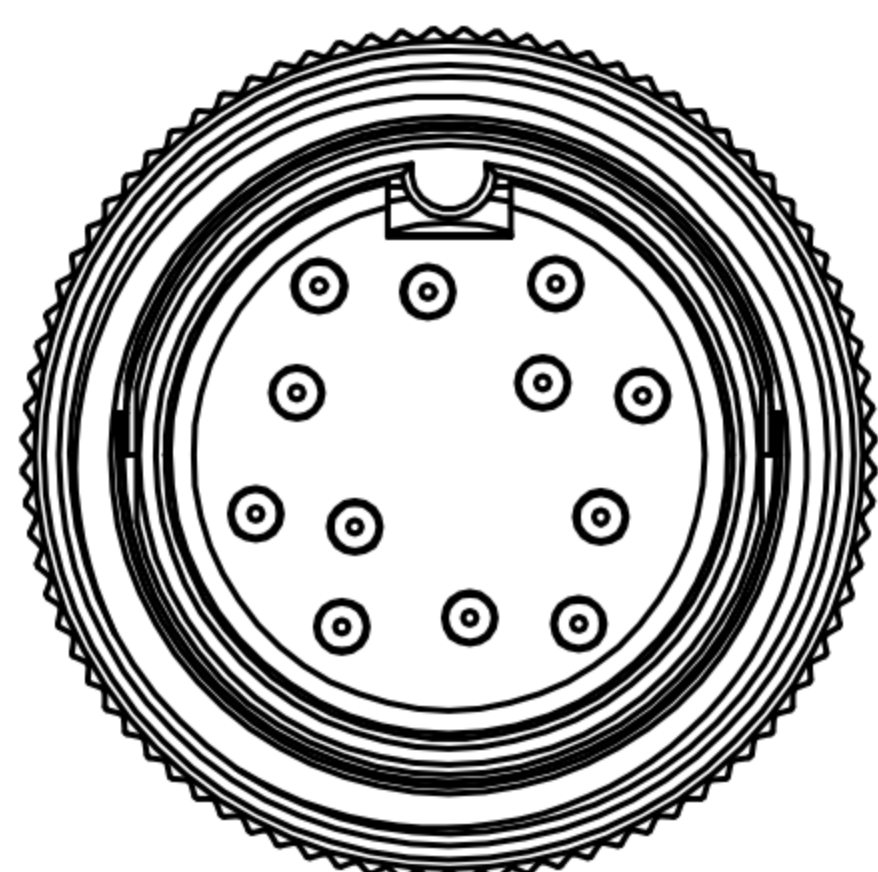

1. MATERIAL :
  - 1-1. HOUSING : NYLON UL94V-0 ; COLOR : BLACK
  - 1-2. CONTACT :BRASS
  - 1-3. CAP : ZINC ALLOY
  - 1-4. CLAMPS BODY : ZINC ALLOY
  - 1-5. SCREW : SPCC
  - 1-6. CLAMPS : ZINC ALLOY
  - 1-7. ISOLATION : PVC
  - 1-8. COAT : BRASS
  - 1-9. BACK BODY : NYLON+GF15% UL94V-0 ;COLOR: BLACK
  - 1-10. SR : PVC
2. FINISH :
  - 2-1. CONTACT : GOLD FLASH MICRO INCHES MIN.
  - 2-2. CAP : NICKEL PLATED
  - 2-3. CLAMPS : NICKEL PLATED
  - 2-4. CLAMPS BODY : NICKEL PLATED
  - 2-5. SCREW : NICKEL PLATED
  - 2-6. COAT : NICKEL PLATED
3. ELECTRICAL SPECIFICATION :
  - 3-1. Rated current : 3PIN~8PIN 5A ; 12PIN 3A
  - 3-2. Rated Voltage : 3PIN~8PIN 250V ;12PIN 60V
  - 3-3. Water proof : IP40
4. Environmental :
  - 4-1. Operation Temperature : -20 ℃~85℃

|               |               |               |               |               |               |               |               |               |
|---------------|---------------|---------------|---------------|---------------|---------------|---------------|---------------|---------------|
|               |               |               |               |               |               |               |               |               |
| DI-03M2-13-11 | DI-04M2-22-11 | DI-05M2-19-11 | DI-05M2-21-11 | DI-06M2-20-11 | DI-07M2-22-11 | DI-07M2-19-11 | DI-08M2-21-11 | DI-12M2-16-11 |

|       |            |       |         |       |     |  |  |  |          |                                    |         |        |                     |
|-------|------------|-------|---------|-------|-----|--|--|--|----------|------------------------------------|---------|--------|---------------------|
| DRAWN | LED        | APP'D | Ku Chou | UNIT  | mm  | TOLERANCE  |  | 广东科斯达电子科技有限公司<br>GUANG DONG KE SI DA ELECTRONIC TECHNOLOGY CO., LTD. | TITLE    | DIN (M) Assembly type(端子表金)(OD6mm) |         |        | SHEET               |
| CHK'D | Emily Suen |       |         | SCALE | 1:1 | .x ±0.20<br>.xx ±0.10<br>.xxx ±0.05<br>.xxxx ±0.03<br>ANGULA ±1° |  |  | PART NO. | SEE TABLE A                        | DWG NO. | QC9388 | 1/3<br>VERSION<br>A |



CUSTOMER DRAWING

| REV. | DESCRIPTION | APPROVED BY | DATE      | ECN NO. |
|------|-------------|-------------|-----------|---------|
| A    | RELEASE     | Emily Suen  | 02/09/19* |         |
| B    |             |             |           |         |
| C    |             |             |           |         |

ASSEMBLY INSTRUCTION

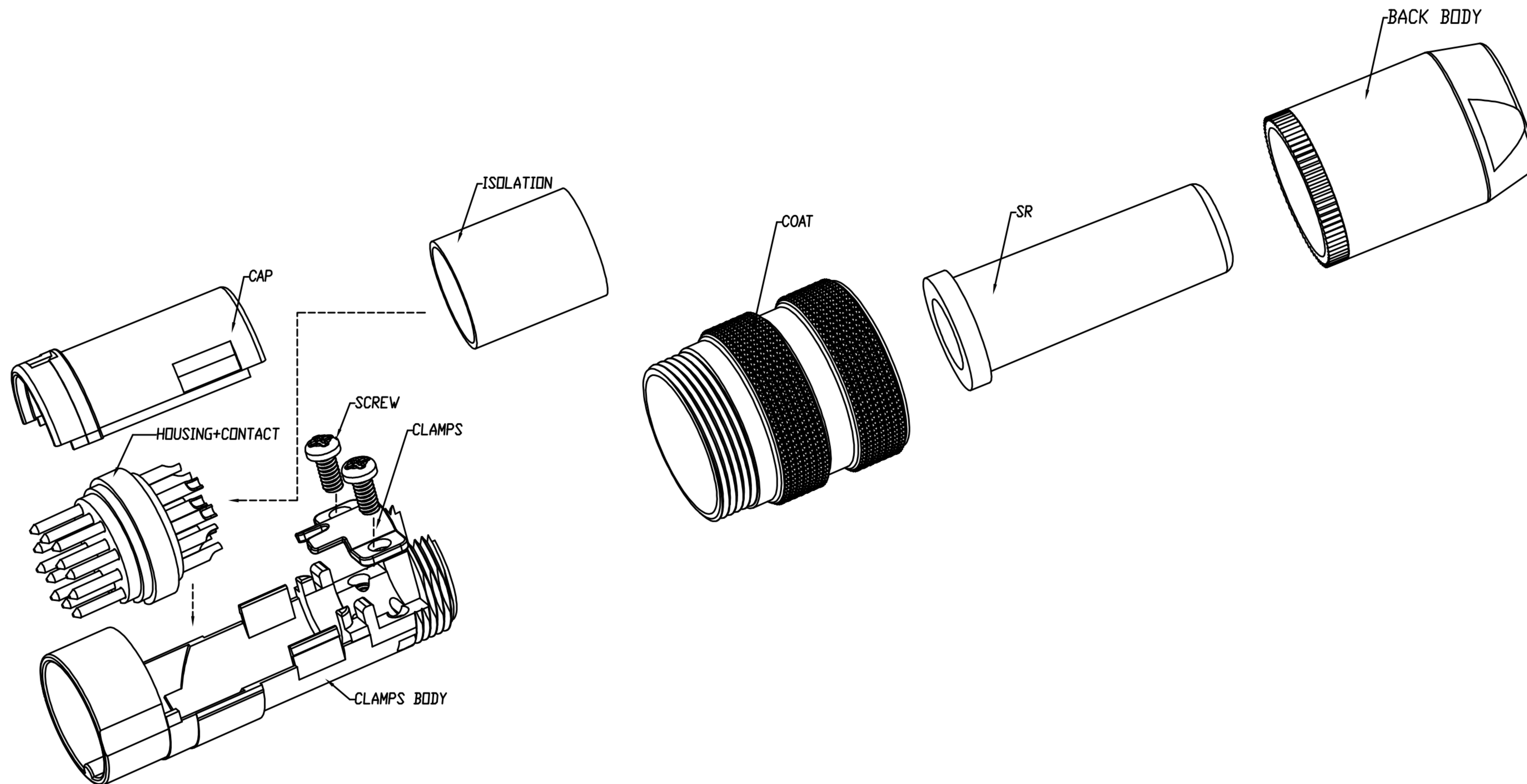

|       |            |       |         |       |     |  |  |  |          |                                    |         |        |         |
|-------|------------|-------|---------|-------|-----|--|--|--|----------|------------------------------------|---------|--------|---------|
| DRAWN | LED        | APP'D | Ku Chou | UNIT  | mm  | TOLERANCE  |  | 广东科斯达电子科技有限公司<br>GUANG DONG KE SI DA ELECTRONIC TECHNOLOGY CO., LTD. | TITLE    | DIN (M) Assembly type(端子夹金)(OD6mm) |         |        | SHEET   |
| CHK'D | Emily Suen |       |         | SCALE | 1:1 | .x ±0.20<br>.xx ±0.10<br>.xxx ±0.05<br>.xxxx ±0.03<br>ANGULA ±1° |  |  | PART NO. | SEE TABLE A                        | DWG NO. | QC9388 | VERSION |