

CUSTOMER DRAWING

REV.	DESCRIPTION	APPROVED BY	DATE	ECN NO.
A	RELEASE	Fido Weng	06/08/09	
B				
C				

1. MATERIAL :
- 1-1. HOUSING :PA66+15%GF ; COLOR : BLACK.
  - 1-2. CONTACT : BRASS
  - 1-3. SHELL : K7
  - 1-4. CAP : K7
  - 1-5. COAT : PA66+15%GF ; COLOR : BLACK.
  - 1-6. SR : PVC ; COLOR : BLACK.
2. FINISH :
- 2-1. CONTACT : NICKEL PLATING
  - 2-2. SHELL : NICKEL PLATED
  - 2-3. COVER : NICKEL PLATED

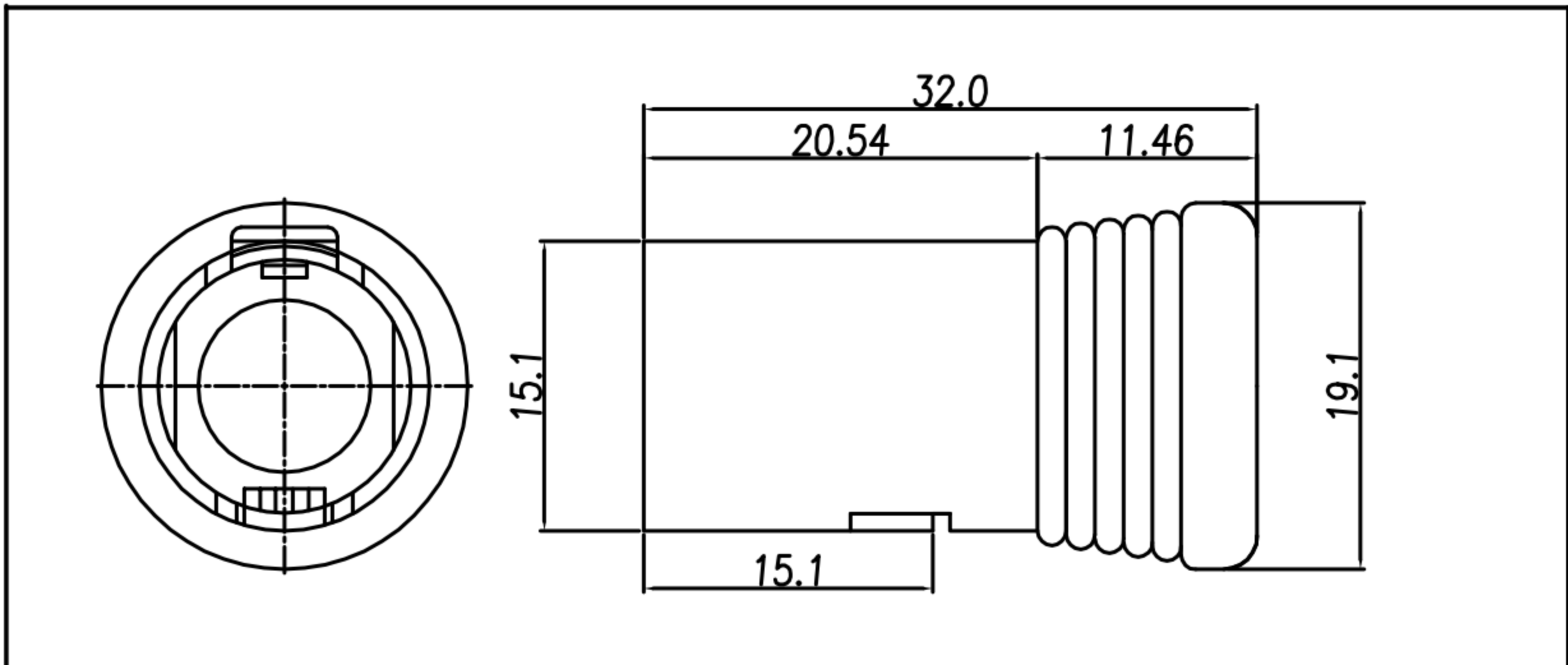

ON-DM0470-01(COAT)

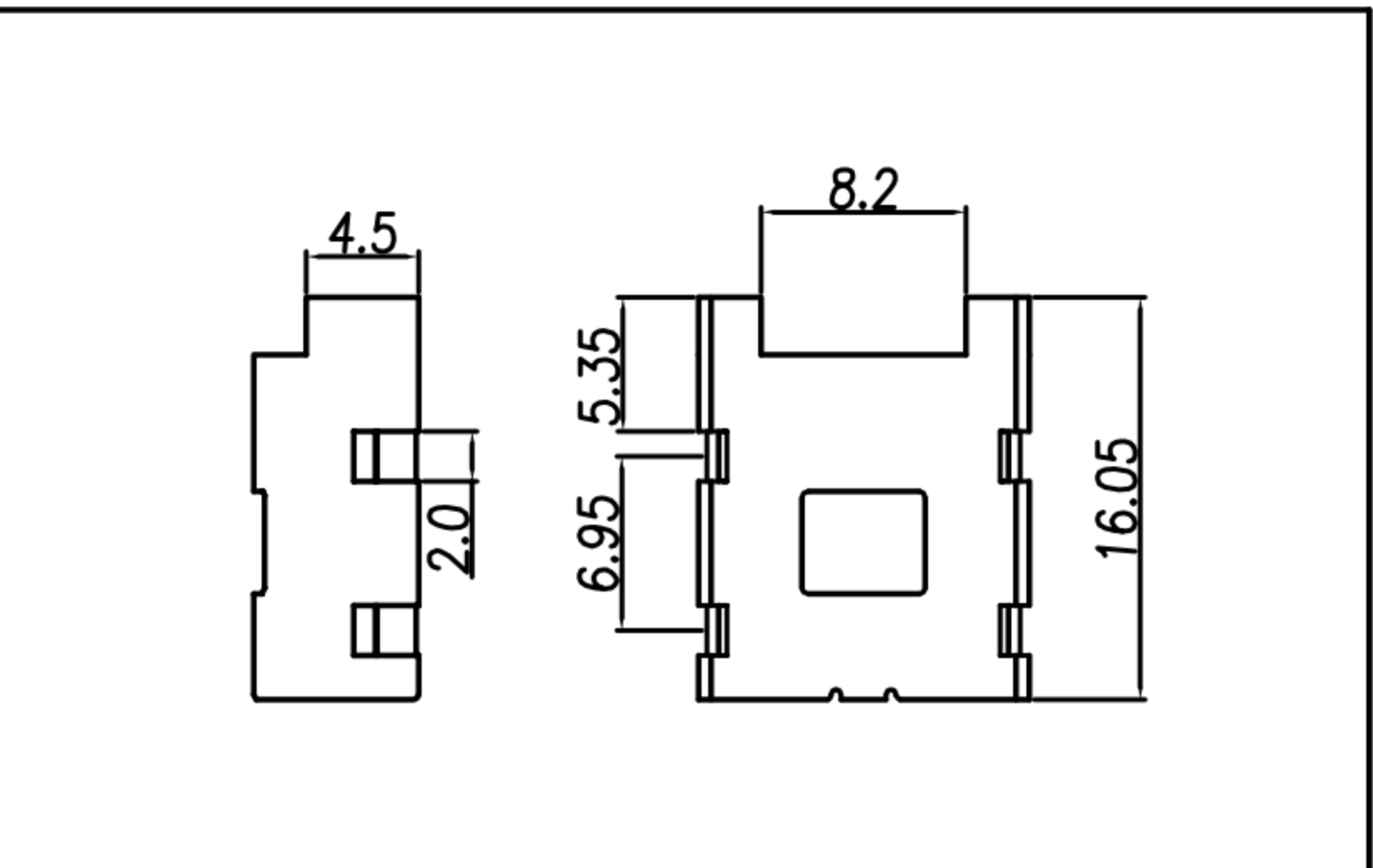

OY-DM0744-10(CAP)

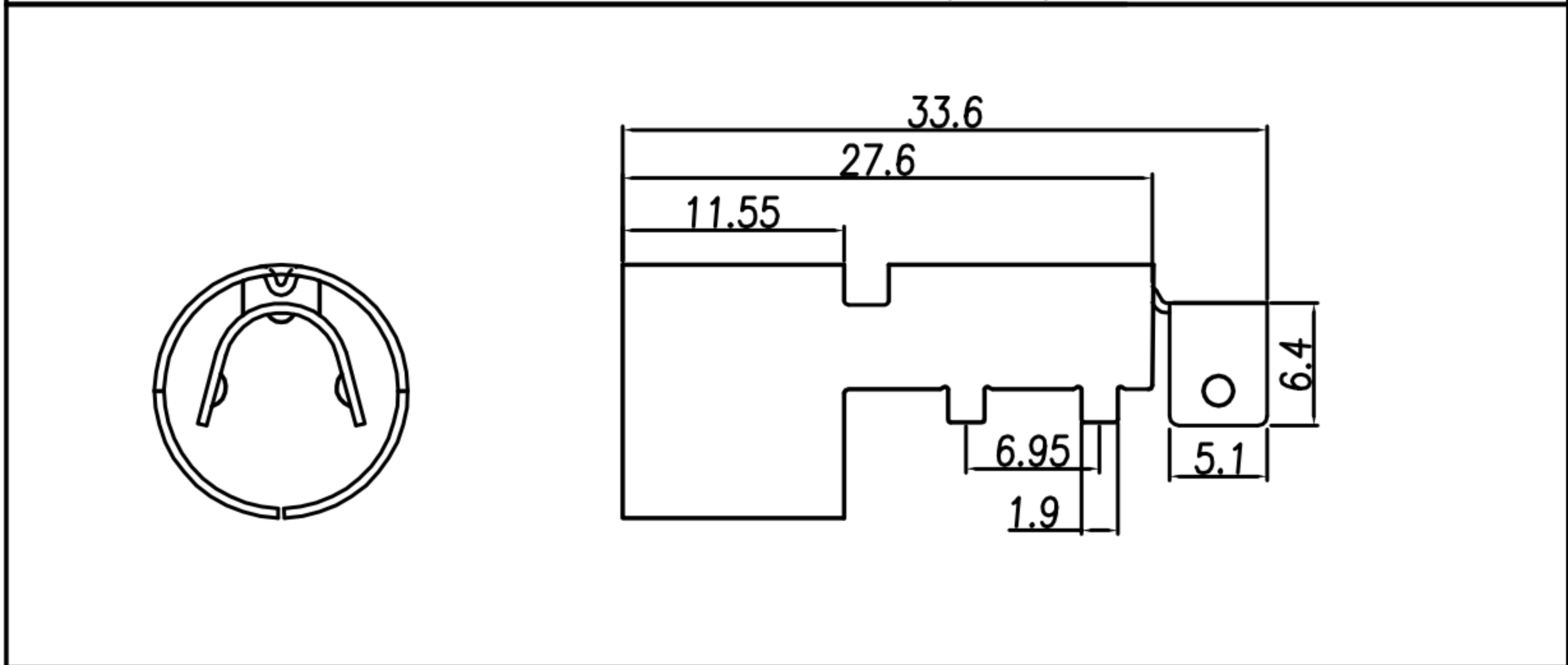

OY-DM0743-10(SHELL)

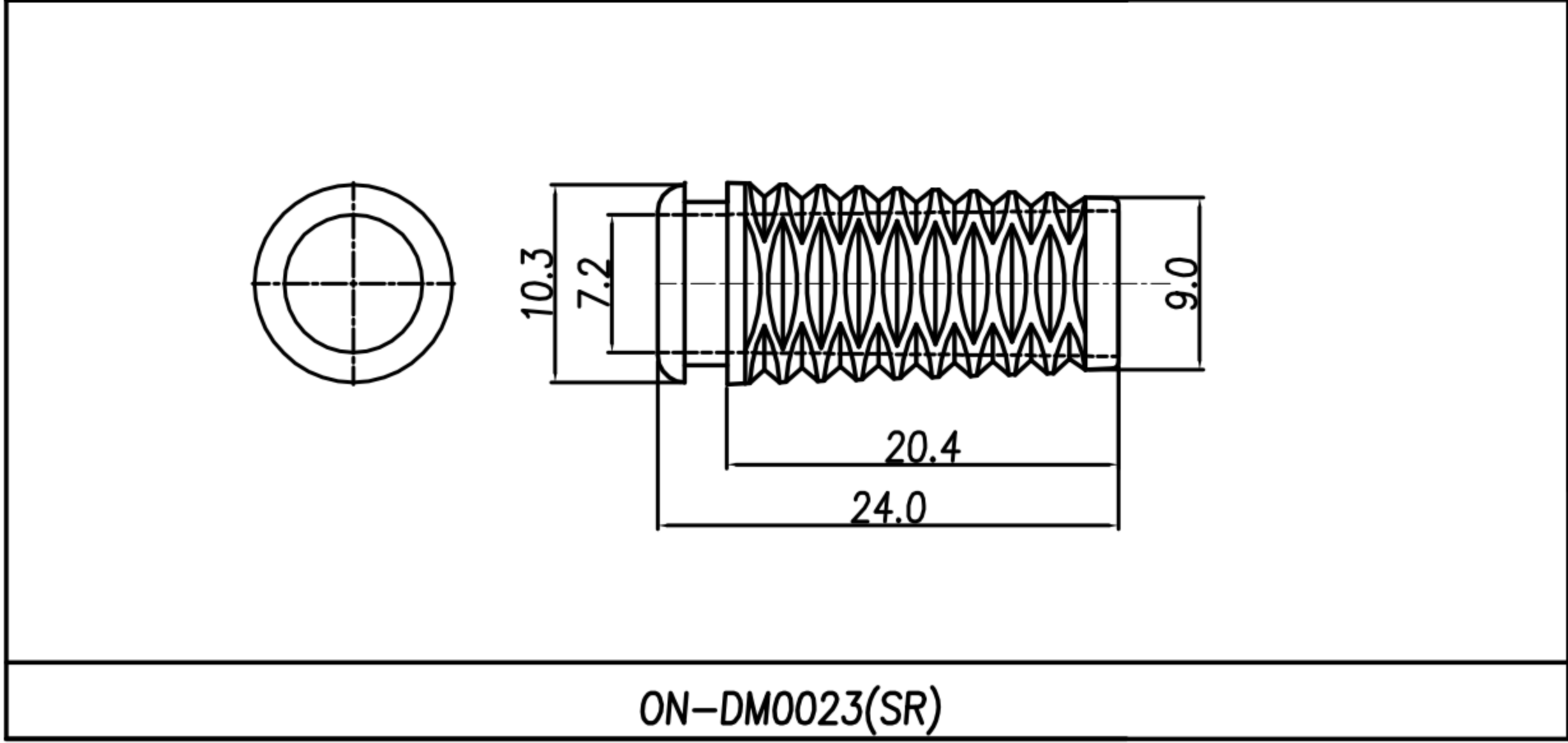
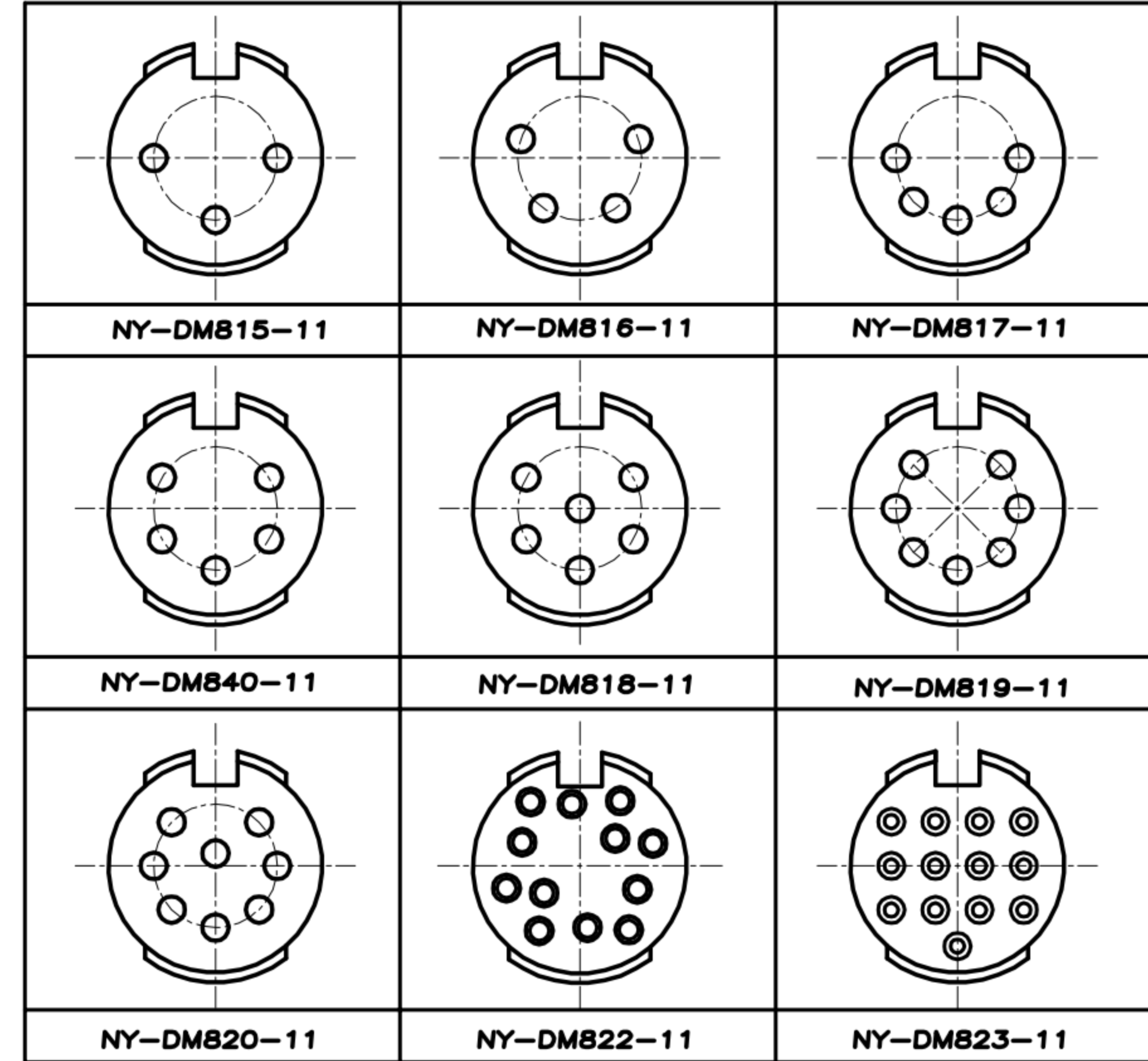

ON-DM0023(SR)

DRAWN	Angus LAI	APP'D	Emily Suen	UNIT	mm	TOLERANCE		广东科斯达电子科技有限公司 GUANG DONG KE SI DA ELECTRONIC TECHNOLOGY CO., LTD.	TITLE	DIN PLUG (M) 装配式			SHEET	3/3
CHK'D	Emily Suen			SCALE	1:1	.x ±0.20 .xx ±0.10 .xxx ±0.05 .xxxx ±0.03 ANGULA ±1°			PART NO.	SEE TABLE A	DWG NO.	QC7568	VERSION	A



CUSTOMER DRAWING

REV.	DESCRIPTION	APPROVED BY	DATE	ECN NO.
A	RELEASE	Fido Weng	06/08/09*	
B				
C				

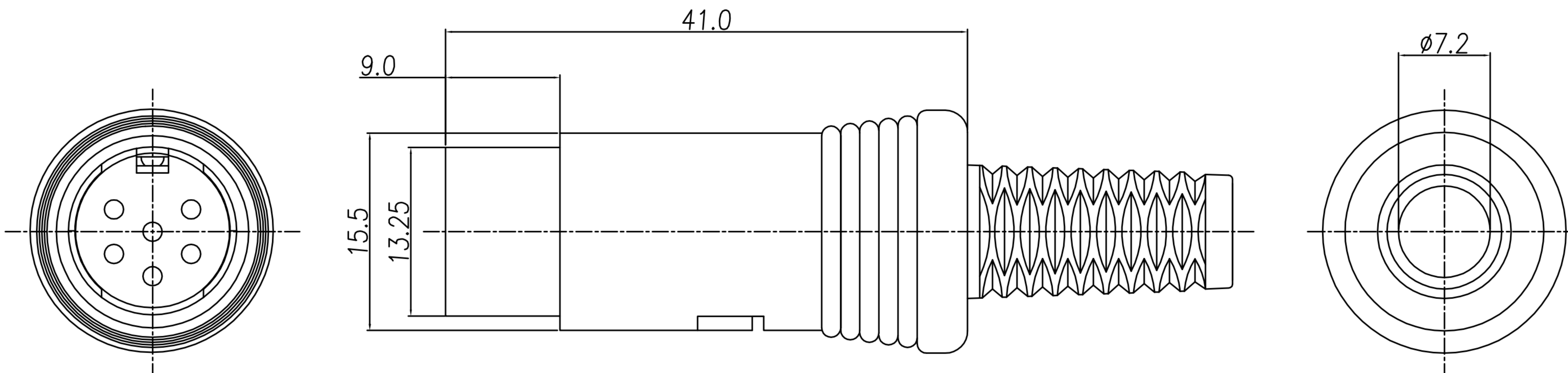

1. MATERIAL :
  - 1-1. HOUSING : PA66+15%GF ; COLOR : BLACK.
  - 1-2. CONTACT : BRASS
  - 1-3. SHELL : K7
  - 1-4. CAP : K7
  - 1-5. COAT : PA66+15%GF ; COLOR : BLACK.
  - 1-6. SR : PVC ; COLOR : BLACK.
2. FINISH :
  - 2-1. CONTACT : NICKEL PLATING
  - 2-2. SHELL : NICKEL PLATED
  - 2-3. COVER : NICKEL PLATED
3. ELECTRICAL SPECIFICATION :
  - 3-1. Rated current: 3PIN~8PIN 5A ; 12PIN~13PIN 3A
  - 3-2. Rated Voltage : 3PIN~8PIN 250V ; 12PIN~13PIN 60V

DI-03M2-09-11	DI-04M2-19-11	DI-05M2-12-11
DI-05M2-15-11	DI-06M2-15-11	DI-07M2-10-11
DI-08M2-17-11	DI-12M2-12-11	DI-13M2-10-11

DRAWN	Angus LAI	APP'D	Emily Suen	UNIT	mm	TOLERANCE		广东科斯达电子科技有限公司 GUANG DONG KE SI DA ELECTRONIC TECHNOLOGY CO., LTD.	TITLE	DIN PLUG (M) 插头			SHEET	3 VERSION A
CHK'D	Emily Suen			SCALE	1:1	.x ±0.20 .xx ±0.10 .xxx ±0.05 .xxxx ±0.03 ANGULA ±1'			PART NO.	SEE TABLE A	DWG NO.	QC7568		



A B C D E F

CUSTOMER DRAWING

REV.	DESCRIPTION	APPROVED BY	DATE	ECN NO.
△A	RELEASE	Fido Weng	06/08/09*	
△B				
△C				

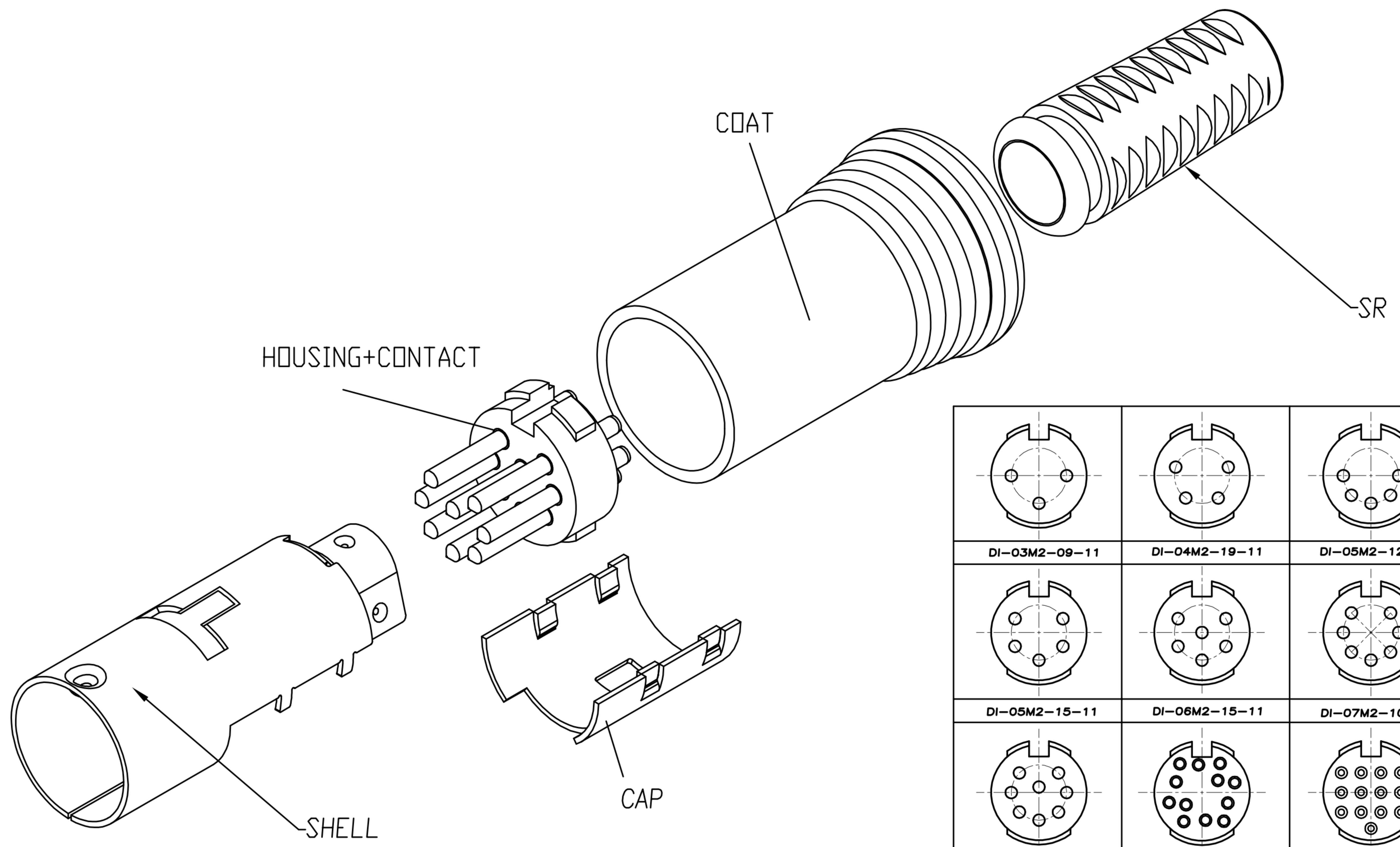

DI-03M2-09-11	DI-04M2-19-11	DI-05M2-12-11
DI-05M2-15-11	DI-06M2-15-11	DI-07M2-10-11
DI-08M2-17-11	DI-12M2-12-11	DI-13M2-10-11

DRAWN	Angus LAI	APP'D	Emily Suen	UNIT	mm	TOLERANCE		广东科斯达电子科技有限公司 GUANG DONG KE SI DA ELECTRONIC TECHNOLOGY CO., LTD.	TITLE	DIN PLUG (M) 插头			SHEET	
CHK'D	Emily Suen			SCALE	1:1	.x ±0.20 .xx ±0.10 .xxx ±0.05 .xxxx ±0.03 ANGULA ±1°			PART NO.	SEE TABLE A	DWG NO.	QC7568	VERSION	