

CUSTOMER DRAWING

REV.	DESCRIPTION	APPROVED BY	DATE	ECN NO.
A	RELEASE	Fido Weng	06/08/09'	
B				ECN1012
C				

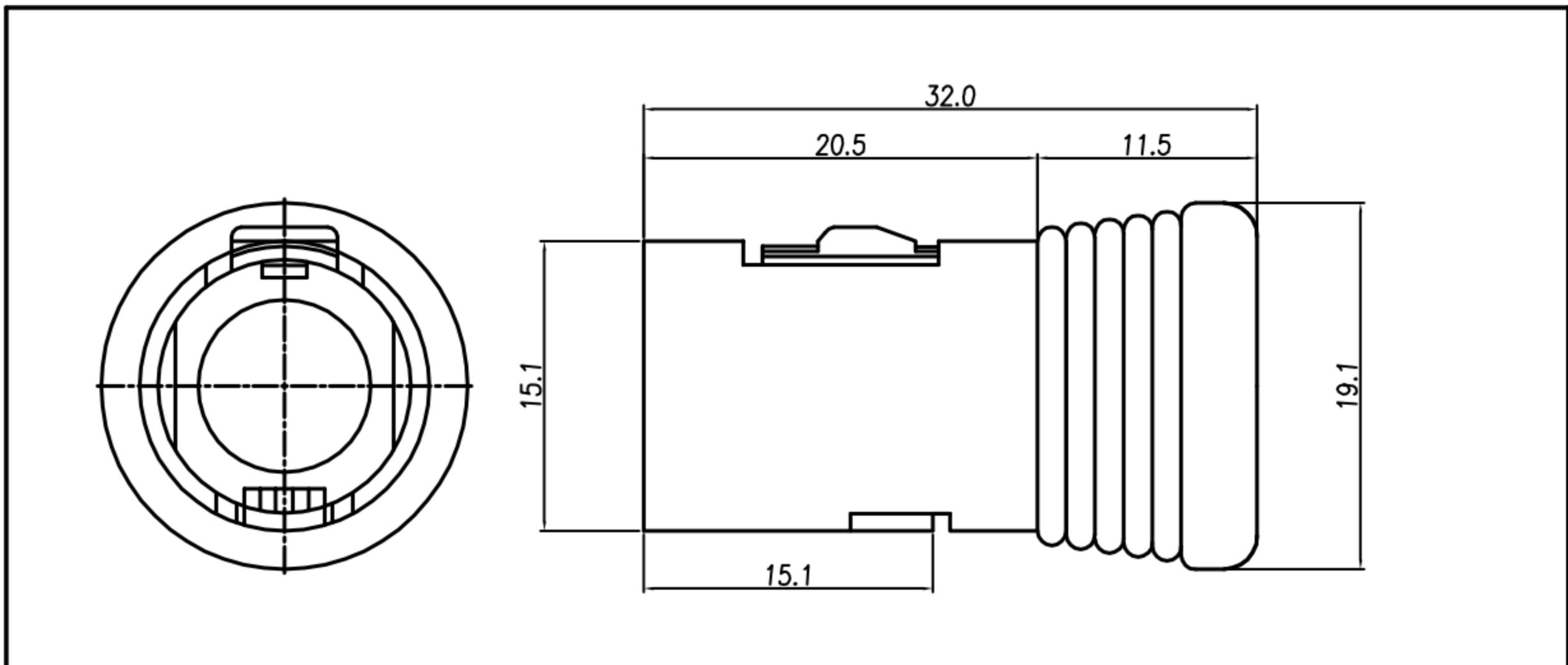

(COAT)

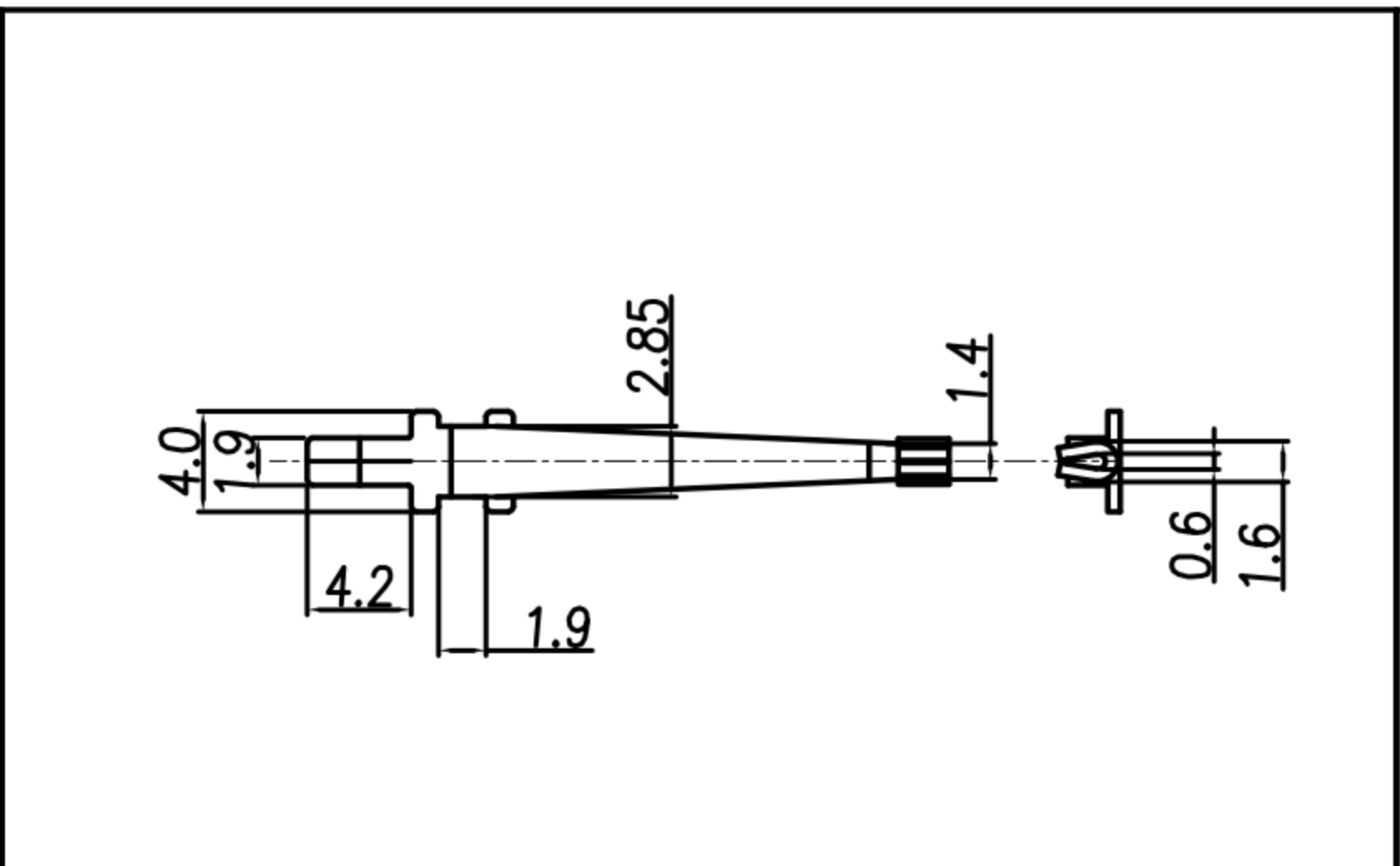

(LOCK)

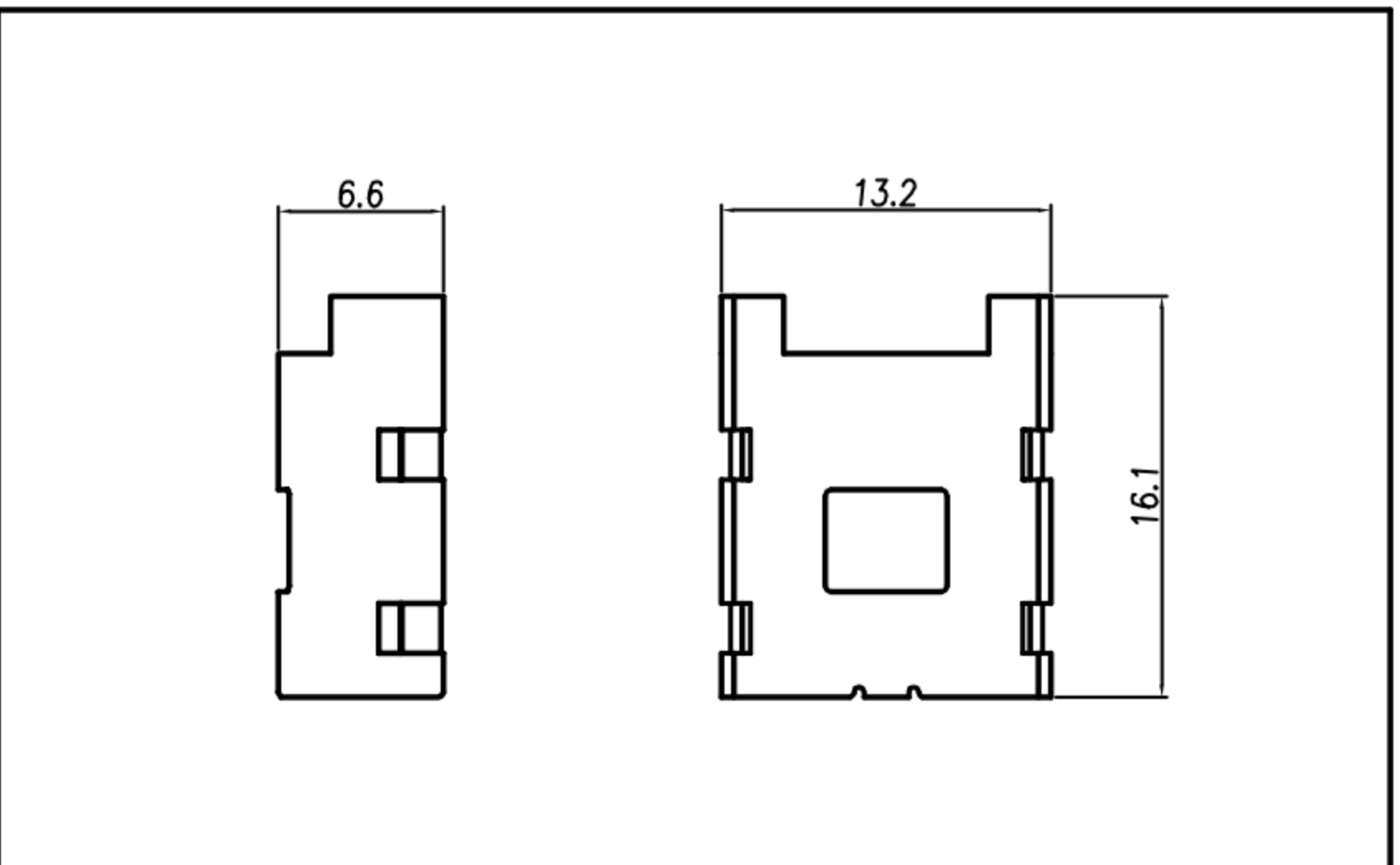

(CAP)

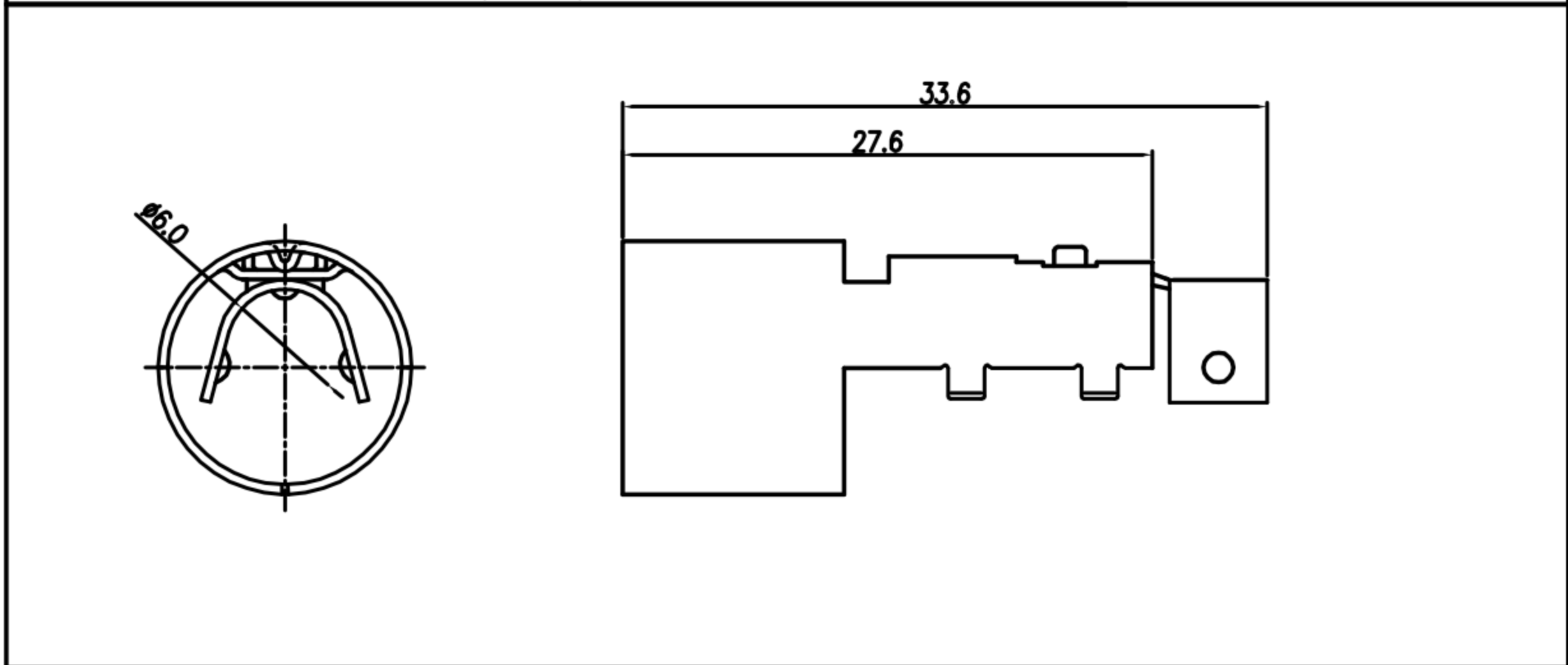

(SHELL)

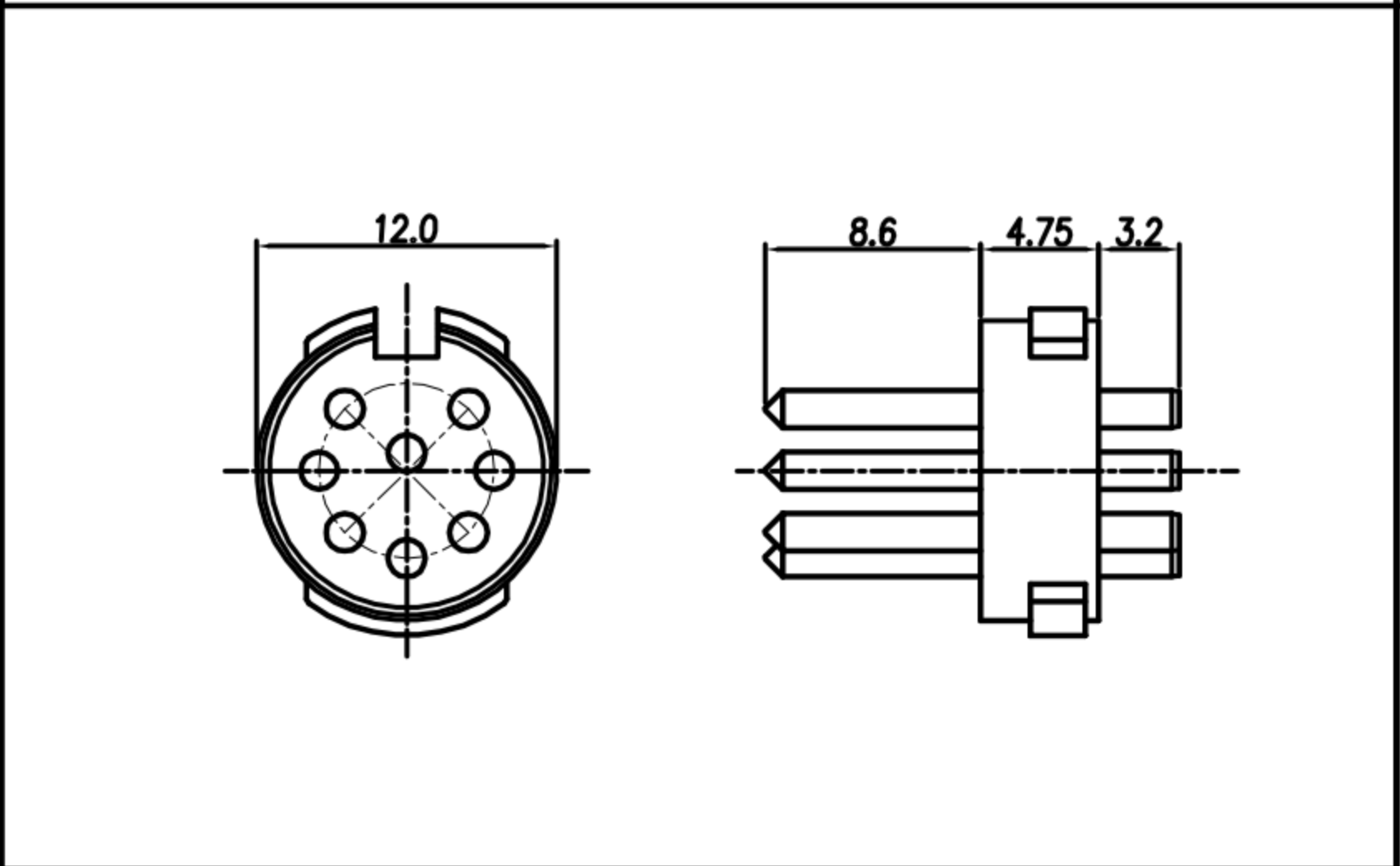

(HOUSING+PIN)

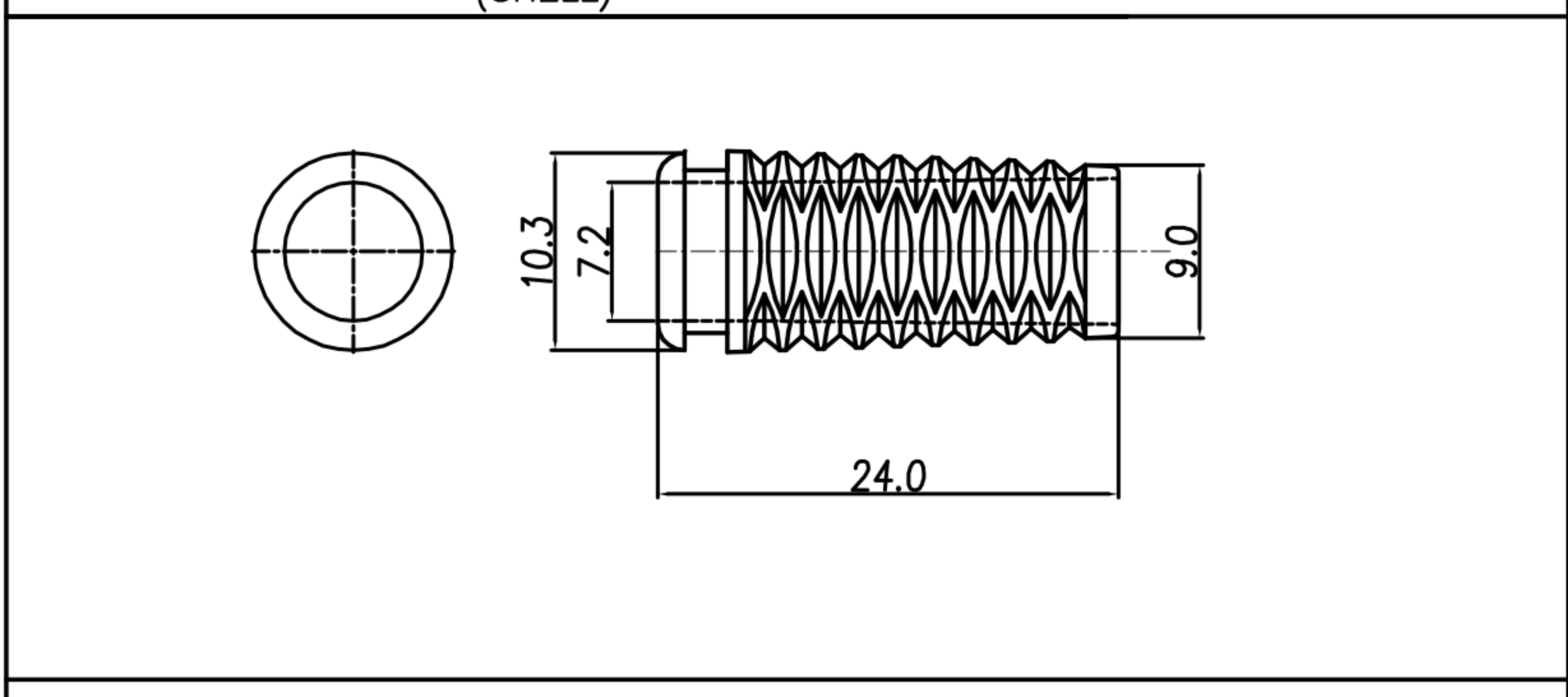

ON-DM0023(SR)

1. MATERIAL :
 - 1-1. HOUSING : PA66+15%GF ; COLOR : BLACK.
 - 1-2. CONTACT : BRASS
 - 1-3. SHELL : K7
 - 1-4. SR : PVC ; COLOR : BLACK.
 - 1-5. COAT : PA66+15%GF;COLOR:BLACK.
 - 1-6. LOCK : BRASS
 - 1-7. CAP : K7
2. FINISH :
 - 2-1. CONTACT : NICKEL PLATED
 - 2-2. SHELL : NICKEL PLATED
 - 2-3. CLASP : NICKEL PLATED
 - 2-4. COVER : NICKEL PLATED

DRAWN	Angus LAI	APP'D	Emily Suen	UNIT	mm	TOLERANCE		广东科斯达电子科技有限公司 GUANG DONG KE SI DA ELECTRONIC TECHNOLOGY CO., LTD.	TITLE	DIN PLUG 装配式带LOCK			SHEET	3/3
CHK'D	Emily Suen			SCALE	1:1	.x ±0.20 .xx ±0.10 .xxx ±0.05 .xxxx ±0.03 ANGULA ±1°			PART NO.	SEE TABLE A	DWG NO.	QC8346	VERSION	A

CUSTOMER DRAWING

REV.	DESCRIPTION	APPROVED BY	DATE	ECN NO.
A	RELEASE	Fido Weng	06/08/09*	
B				
C				

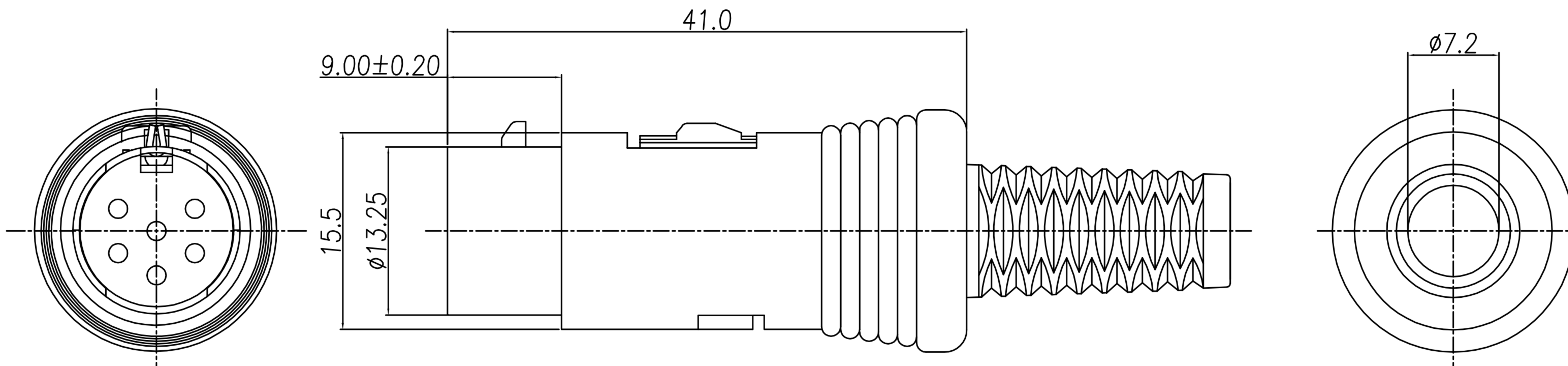

1. MATERIAL :

- 1-1. HOUSING : PA66+15%GF ; COLOR : BLACK.
- 1-2. CONTACT : BRASS
- 1-3. SHELL : K7
- 1-4. CAP : K7
- 1-5. COAT : PA66+15%GF ; COLOR : BLACK.
- 1-6. SR : PVC ; COLOR : BLACK.
- 1-7. LOCK : BRASS.

2. FINISH :

- 2-1. CONTACT : NICKEL PLATING
- 2-2. SHELL : NICKEL PLATED
- 2-3. COVER : NICKEL PLATED
- 2-4. LOCK : NICKEL PLATED

3. ELECTRICAL SPECIFICATION :

- 3-1. Rated current: 3PIN~8PIN 5A ; 12PIN~13PIN 3A
- 3-2. Rated Voltage : 3PIN~8PIN 250V ; 12PIN~13PIN 60V

DI-03M2-11-11	DI-04M2-20-11	DI-05M2-16-11
DI-05M2-17-11	DI-06M2-18-11	DI-07M2-12-11
DI-08M2-19-11	DI-12M2-13-11	DI-13M2-12-11

DRAWN	Angus LAI	APP'D	Emily Suen	UNIT	mm	TOLERANCE			TITLE	DIN PLUG 插式带LOCK			SHEET
CHK'D	Emily Suen			SCALE	1:1	.x ±0.20 .xx ±0.10 .xxx ±0.05 .xxxx ±0.03 ANGULA ±1'			PART NO.	SEE TABLE A	DWG NO.	QC8346	VERSION

A B C D E F

CUSTOMER DRAWING

REV.	DESCRIPTION	APPROVED BY	DATE	ECN NO.
△A	RELEASE	Fido Weng	06/08/09*	
△B				
△C				

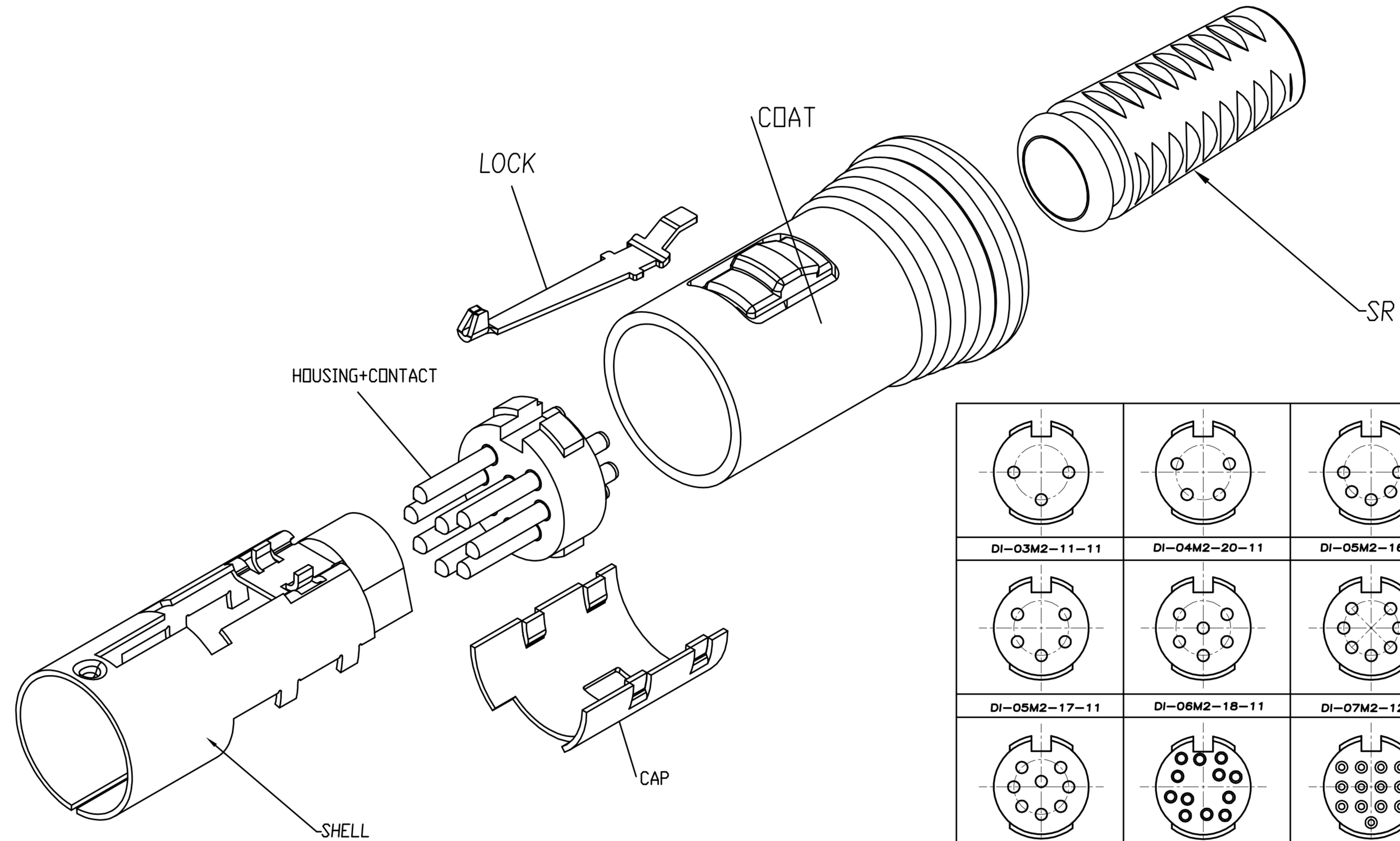

DI-03M2-11-11	DI-04M2-20-11	DI-05M2-16-11
DI-05M2-17-11	DI-06M2-18-11	DI-07M2-12-11
DI-08M2-19-11	DI-12M2-13-11	DI-13M2-12-11

DRAWN	Angus LAI	APP'D	Emily Suen	UNIT	mm	TOLERANCE		广东科斯达电子科技有限公司 GUANG DONG KE SI DA ELECTRONIC TECHNOLOGY CO., LTD.	TITLE	DIN PLUG 插式 LOCK			SHEET	2
CHK'D	Emily Suen			SCALE	1:1	.x ±0.20 .xx ±0.10 .xxx ±0.05 .xxxx ±0.03 ANGULA ±1°			PART NO.	SEE TABLE A	DWG NO.	QC8346	VERSION	A