

CUSTOMER DRAWING

REV.	DESCRIPTION	APPVL. BY	DATE	ECN NO.
A	RELEASE	Fido Weng	05/09/16"	
B				
C				

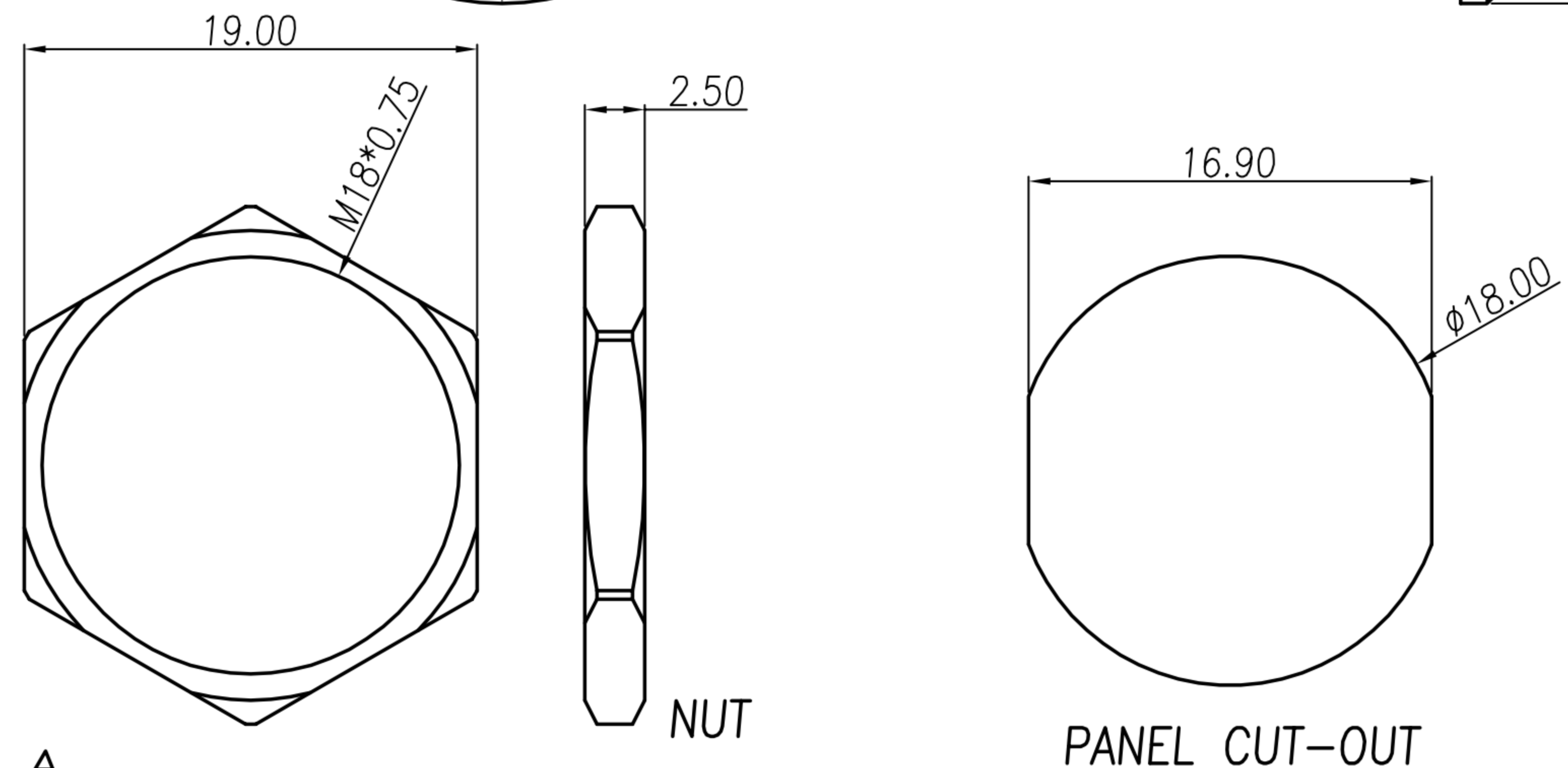
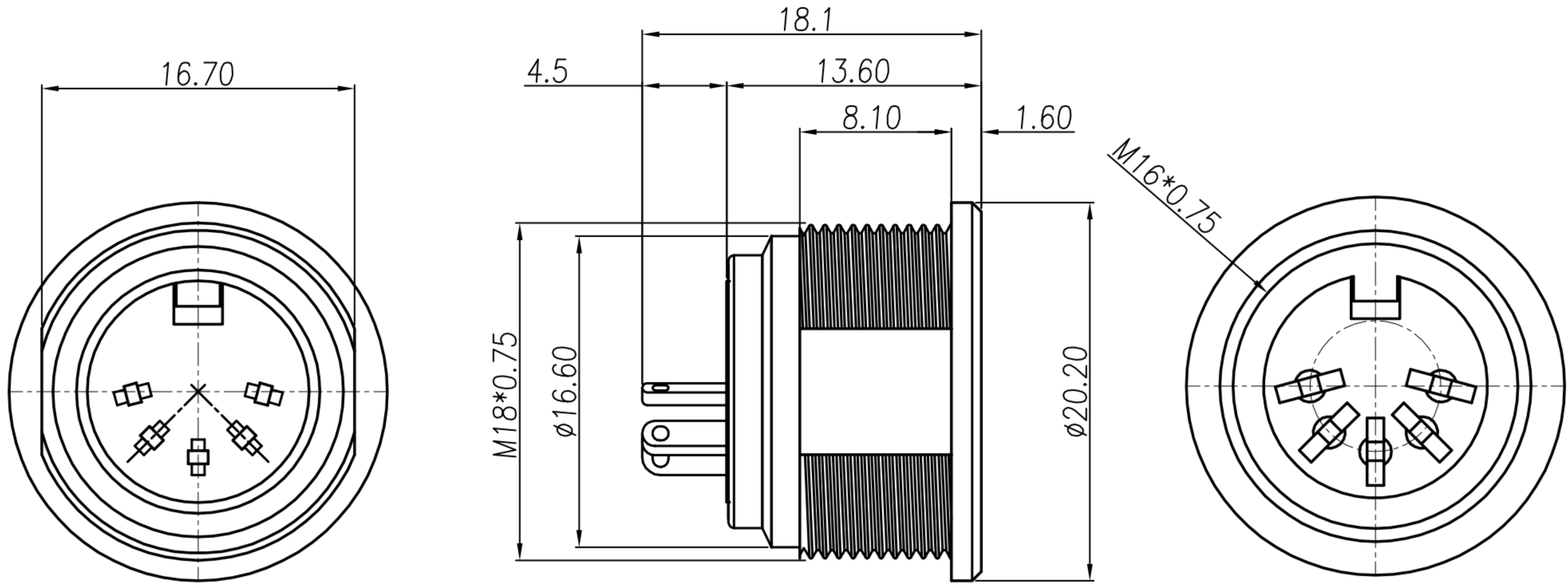

- NOTE**
1. MATERIAL :
 - 1-1. HOUSING : PBT UL94V-0 ; COLOR : BLACK
 - 1-2. CONTACT : BRASS.
 - 1-3. SHELL : BRASS
 - 1-4. NUT : BRASS
 2. FINISH :
 - 2-1. CONTACT : SILVER PLATED.
 - 2-2. SHELL : NICKEL PLATED.
 - 2-3. NUT : NICKEL PLATED.
 3. ELECTRICAL SPECIFICATION :
 - 3-1. Rated current : 5A
 - 3-2. Rated Voltage : 250V
 4. Environmental :
 - 4-1. Operation Temperature : -25℃~85℃

TABLE A

DI-03F2-08-11	DI-04F2-16-11	DI-05F2-11-11	DI-06F2-19-11	DI-07F2-10-11	DI-08F2-10-11

DRAW	Lai Angus	APPVL	Emily Suen	UNIT	mm	TOLERANCE		广东科斯达电子科技有限公司 GUANG DONG KE SI DA ELECTRONIC TECHNOLOGY CO., LTD.	TITLE	DIN M16X0.75 (F) 後鎖螺絲式(魚叉式端子)			SHEET	+
CHECK	Emily Suen			SCALE	1:1	.x ±0.20 .xx ±0.10 .xxx ±0.05 .xxxx ±0.03 ANGULA ±1°		PART NO.	SEE TABLE A	DWG NO.	QC7583	VERSION	A	