

CUSTOMER COMPONENTS DRAWING

REV.	DESCRIPTION	APPROVED BY	DATE	ECN NO.
A	RELEASE	Fido Weng	06/08/09'	
B				
C				

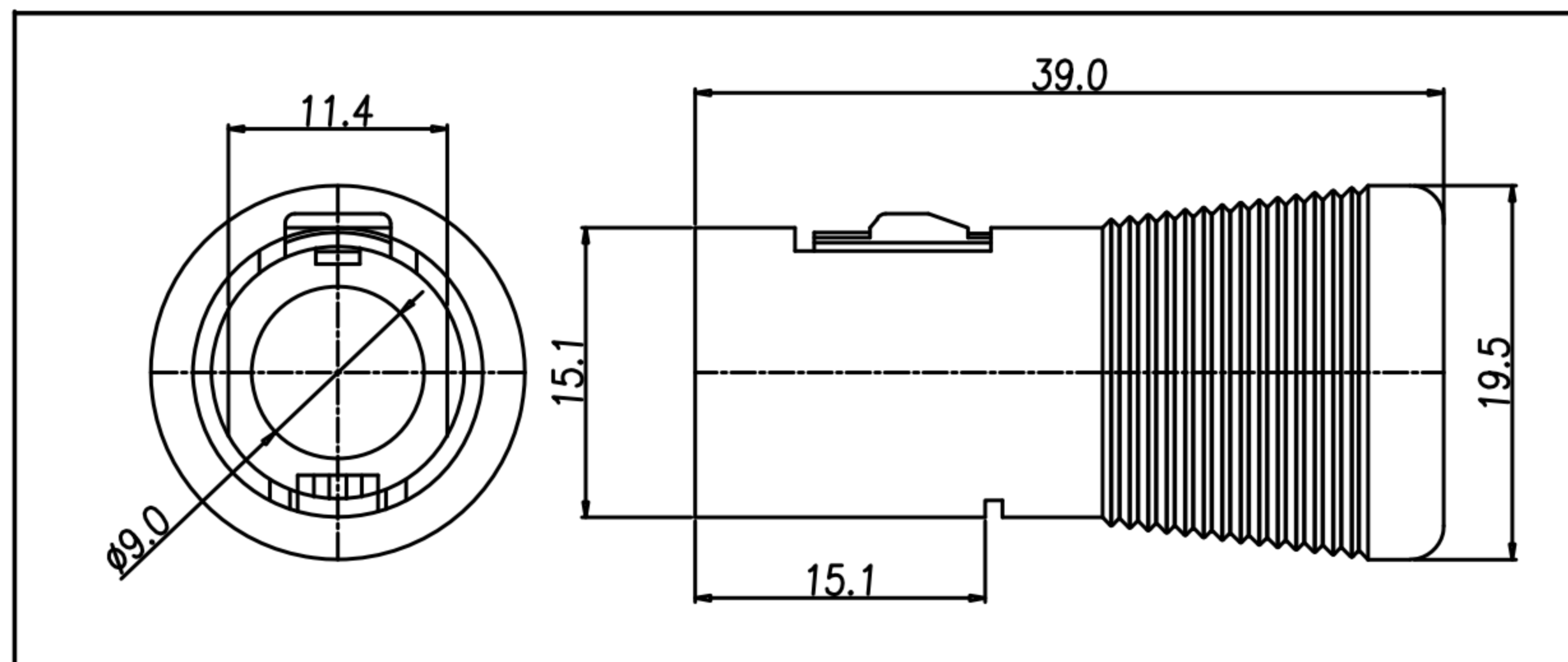

DN-DM0022(COAT)

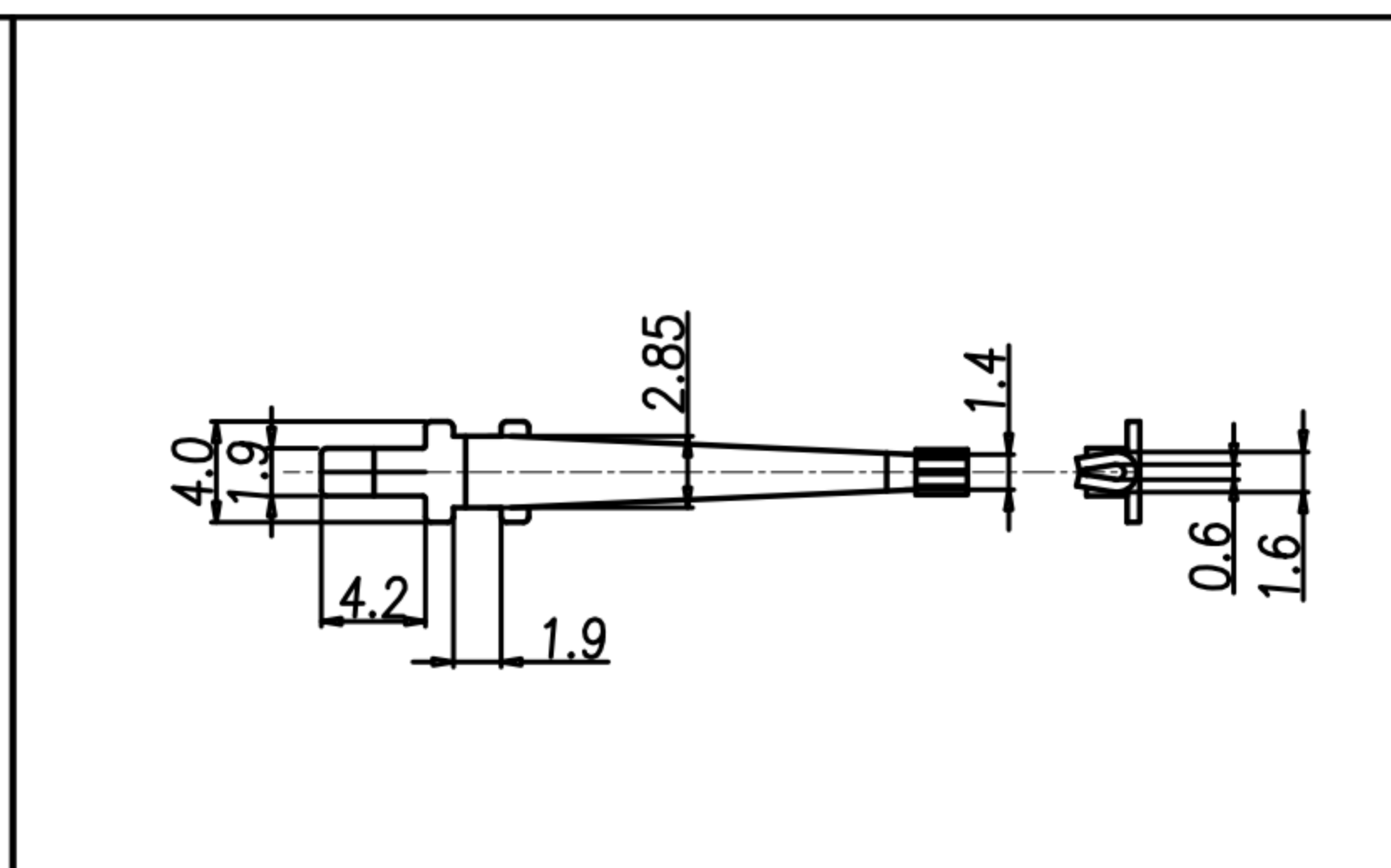

DY-DM0037(CLASP)

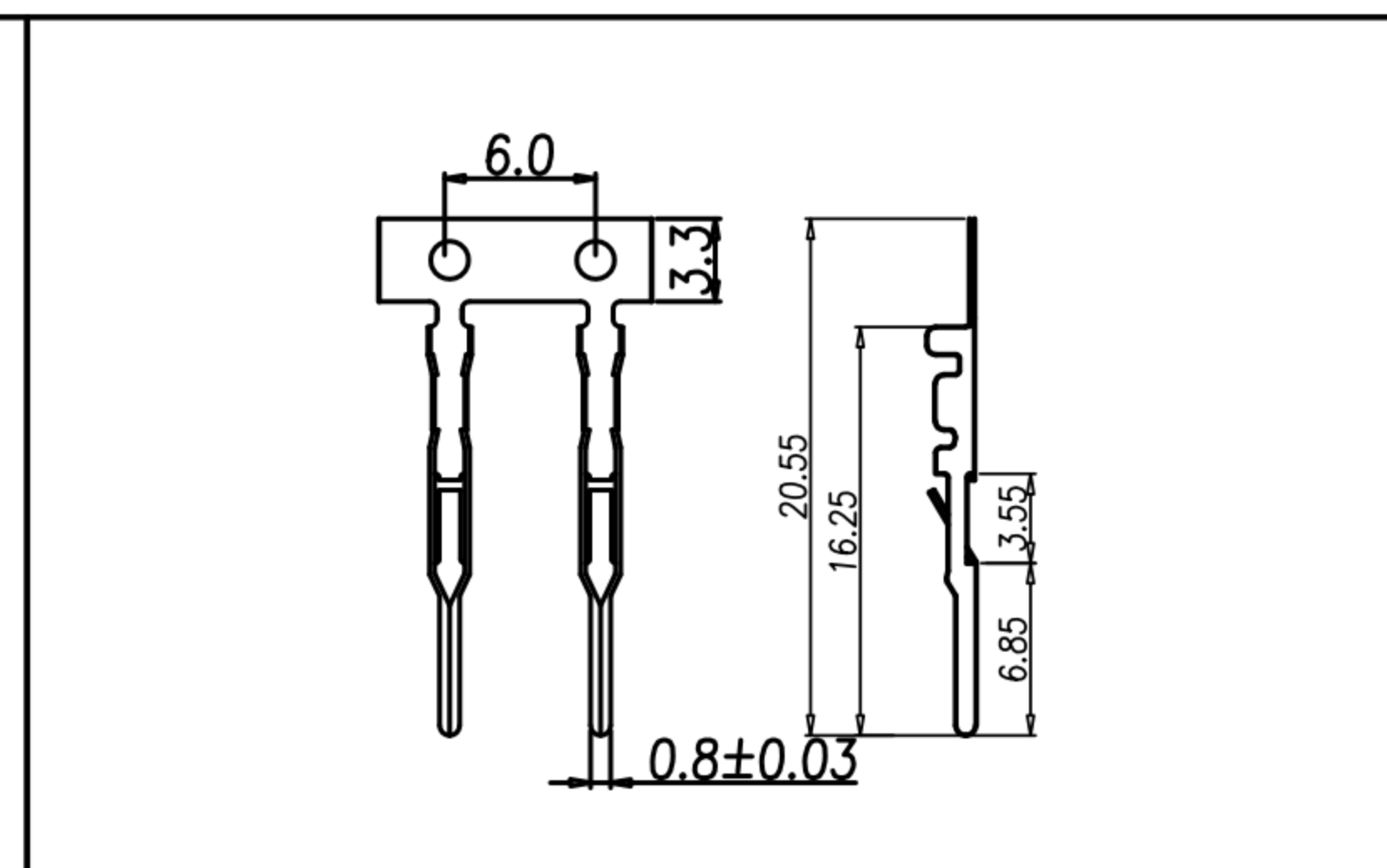

DY-DM0240(CONTACT)

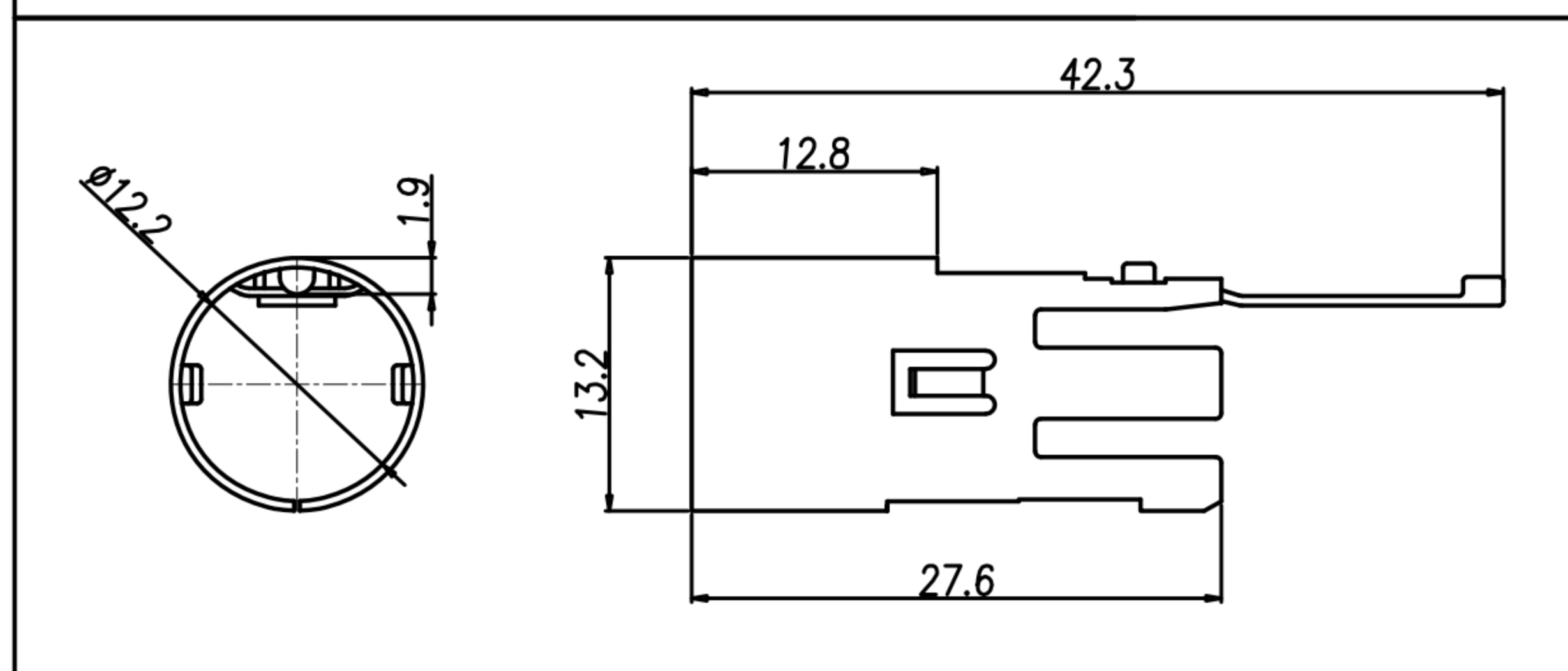

DY-DM0035(SHELL)

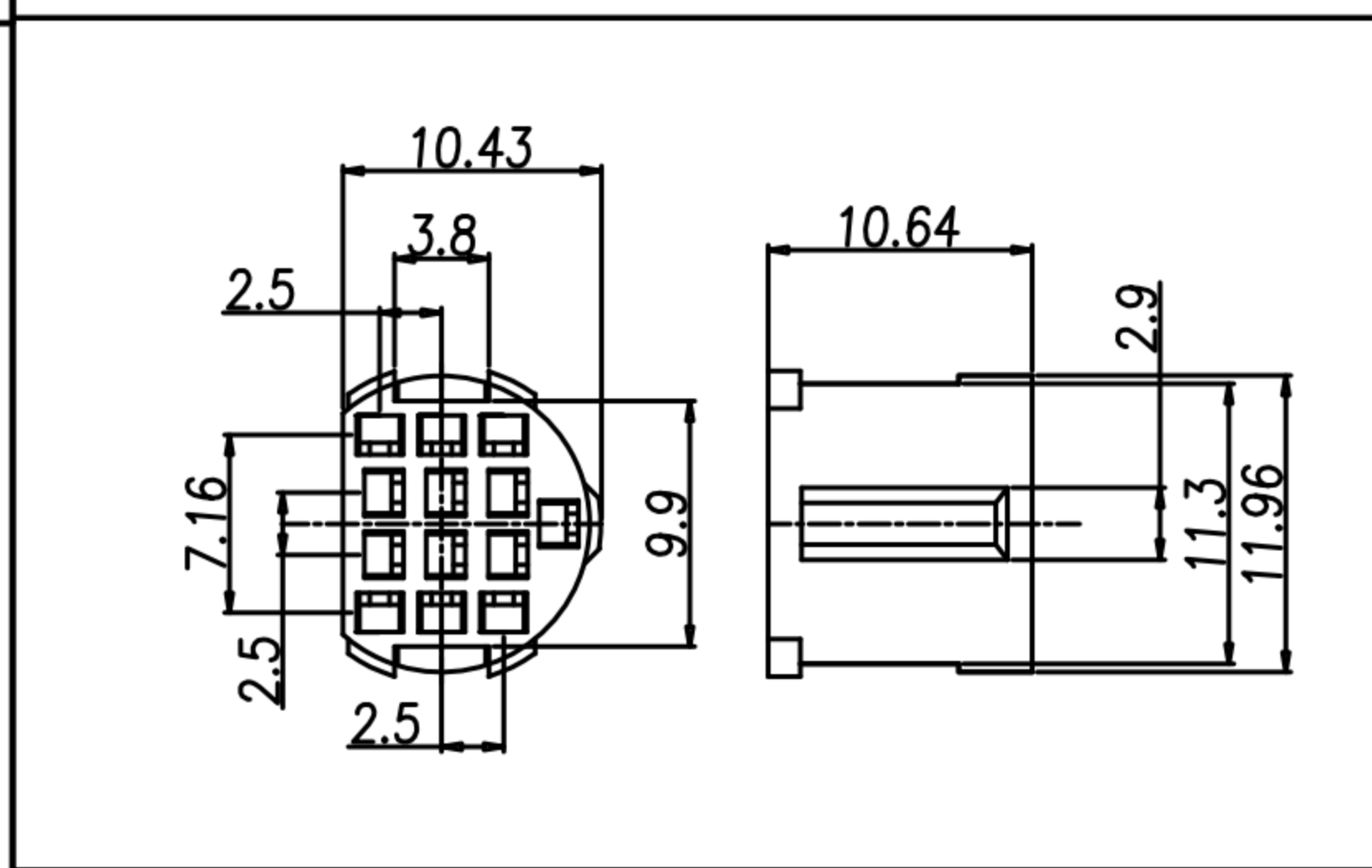

DN-DM0024(HOUSING)

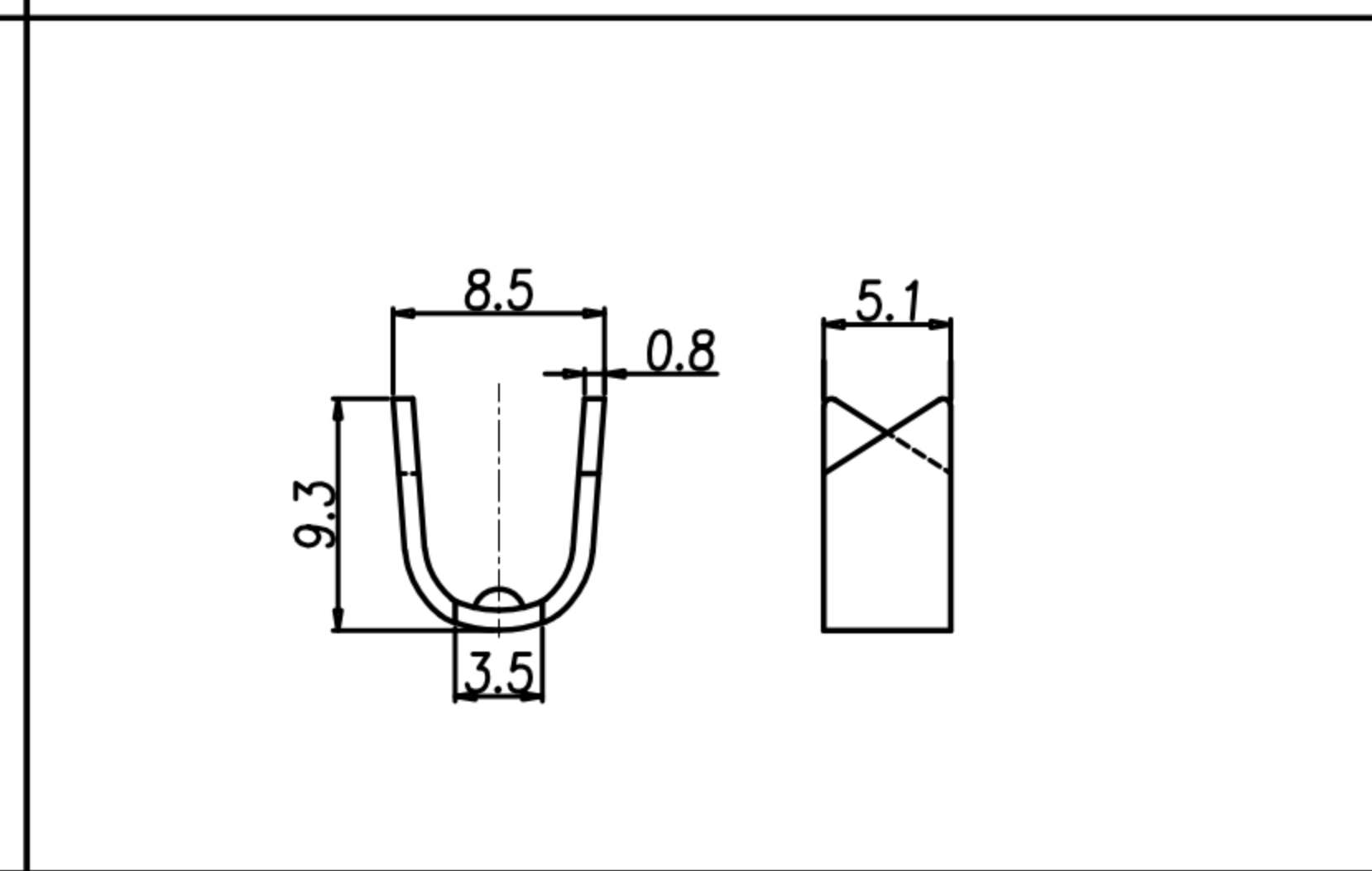

DY-DM0006(LINE BUCKLE)

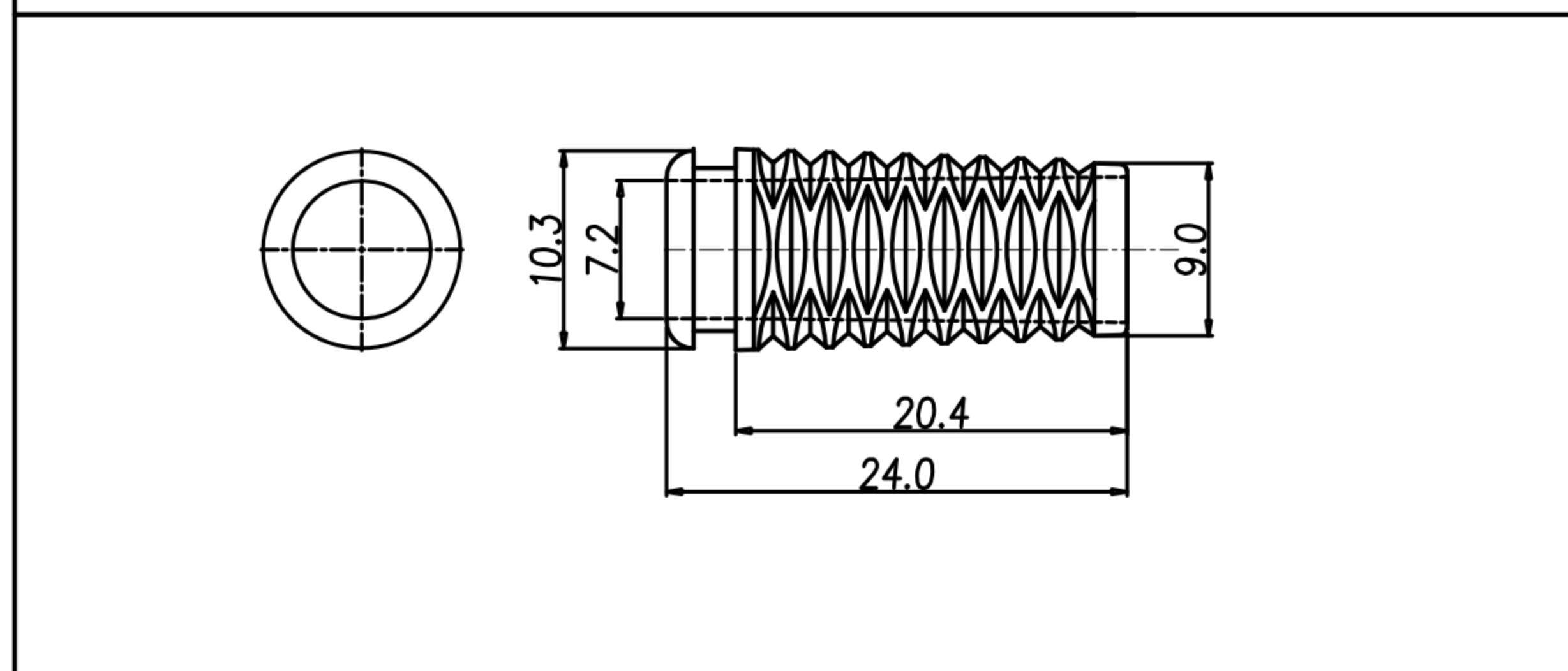

DN-DM0023(SR)

1. MATERIAL :

- 1-1. HOUSING : PBT ; COLOR : BLACK.
- 1-2. CONTACT : PHOSPHOR BRONZE.
- 1-3. SHELL : BRASS.
- 1-4. SR : PVC ; COLOR : BLACK.
- 1-5. COAT : PBT ; COLOR : BLACK.
- 1-6. CLASP : BRASS
- 1-7. LINE BUCKLE : BRASS

2. FINISH :

- 2-1. CONTACT : GOLD FLISH MICRO INCHES MIN.
- 2-2. SHELL : NICKEL PLATED
- 2-3. CLASP : NICKEL PLATED
- 2-4. SHELL : NICKEL PLATED

DRAWN	Mark Kao	APP'D	Ku Chou	UNIT	mm	TOLERANCE
CHK'D	Ku Chou			SCALE	1:1	.x ±0.20 .xx ±0.10 .xxx ±0.05 .xxxx ±0.03 ANGULA ±1°

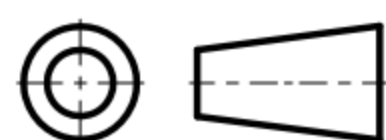

TITLE	DIN PLUG 13P 成品			SHEET	2/2
PART NO.	DI-13M2-01	DWG NO.	QC0113	VERSION	A

CUSTOMER DRAWING

REV.	DESCRIPTION	APPROVED BY	DATE	ECN NO.
A	RELEASE	Fido Weng	06/08/09'	
B				
C				

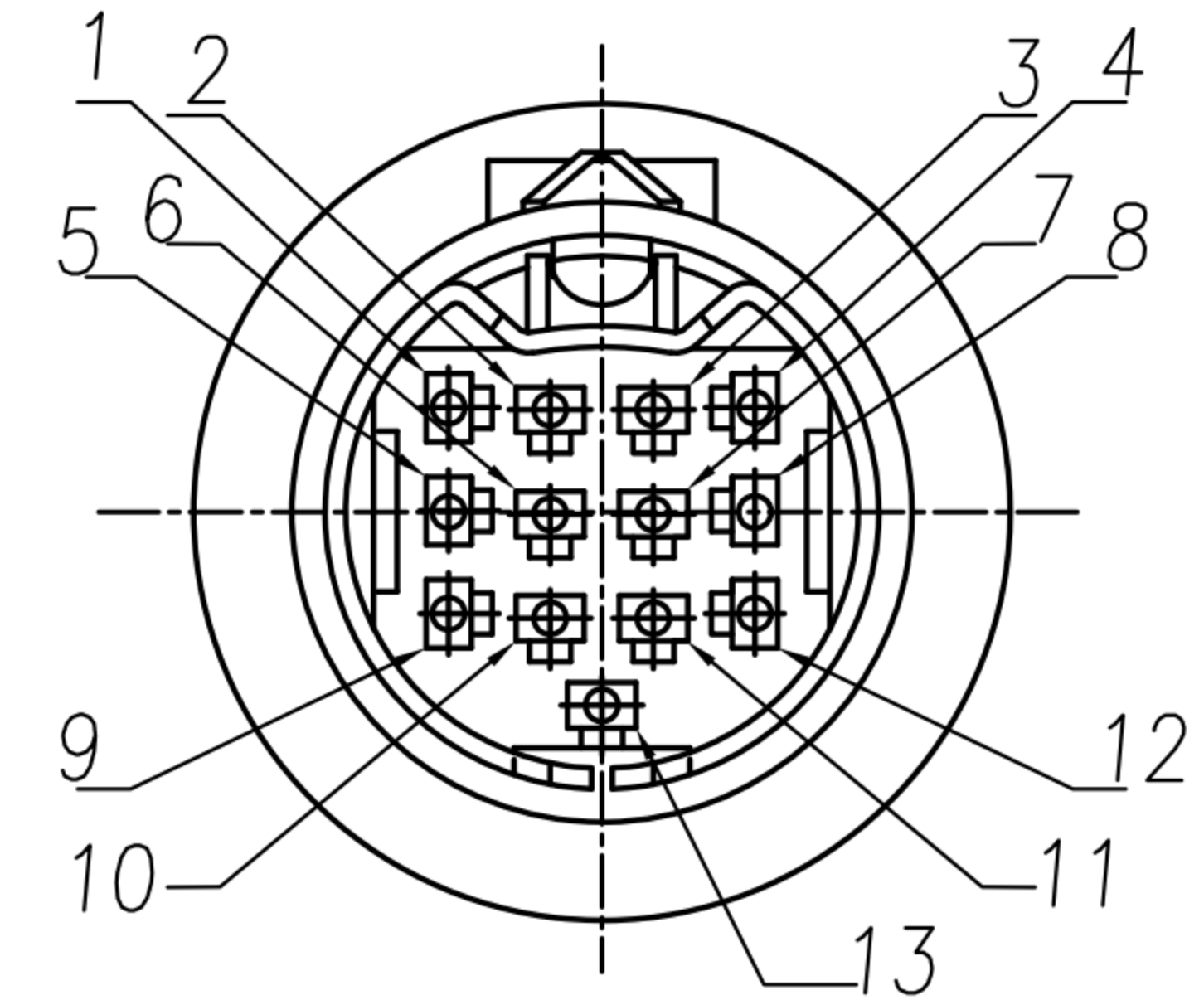
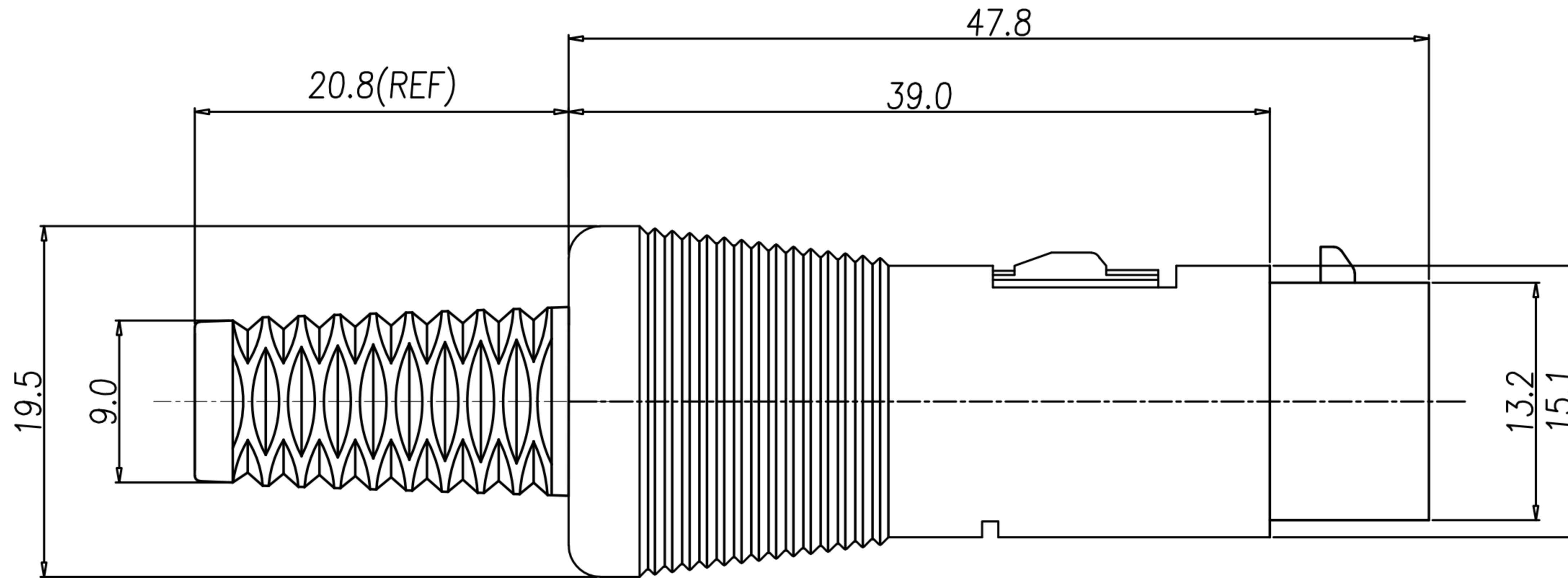

1. MATERIAL :
 - 1-1. HOUSING : PBT ; COLOR : BLACK.
 - 1-2. CONTACT : PHOSPHOR BRONZE.
 - 1-3. SHELL : BRASS.
 - 1-4. SR : PVC ; COLOR : BLACK.
 - 1-5. COAT : PBT ; COLOR : BLACK.
 - 1-6. CLASP : BRASS
 - 1-7. LINE BUCKLE : BRASS
2. FINISH :
 - 2-1. CONTACT : GOLD FLISH MICRO INCHES MIN.
 - 2-2. SHELL : NICKEL PLATED
 - 2-3. CLASP : NICKEL PLATED
 - 2-4. SHELL : NICKEL PLATED

3. ELECTRICAL SPECIFICATION :
 - 3-1. Rated current : 3A
 - 3-2. Rated oltage : 60V
4. Environmental :
 - 4-1. Operation Temperature : -20 °C~85°C

DRAWN	Mark Kao	APP'D	Ku Chou	UNIT	mm	TOLERANCE		广东科斯达电子科技有限公司 GUANG DONG KE SI DA ELECTRONIC TECHNOLOGY CO., LTD.	TITLE	DIN PLUG 13P 成品			SHEET	1/2
CHK'D	Ku Chou			SCALE	1:1	.x ±0.20 .xx ±0.10 .xxx ±0.05 .xxxx ±0.03 ANGULA ±1°			PART NO.	DI-13M2-01	DWG NO.	QC0113	VERSION	A