

CUSTOMER DRAWING

REV.	DESCRIPTION	APPROVED BY	DATE	ECN NO.
△A				
△B				
△C				

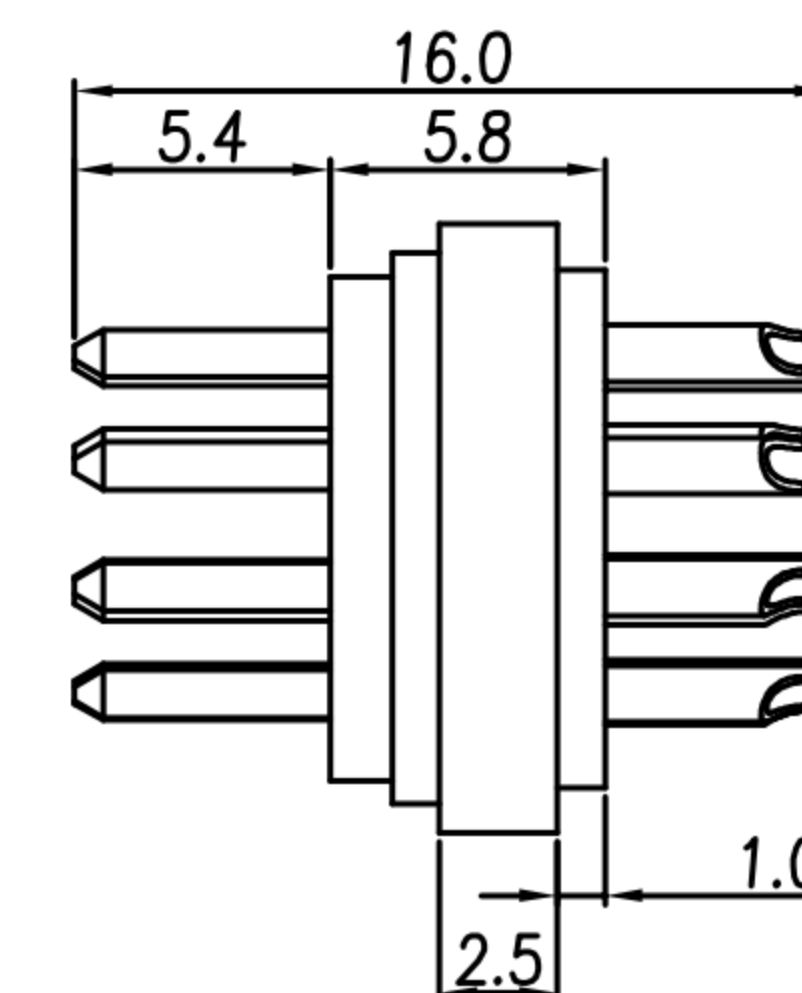
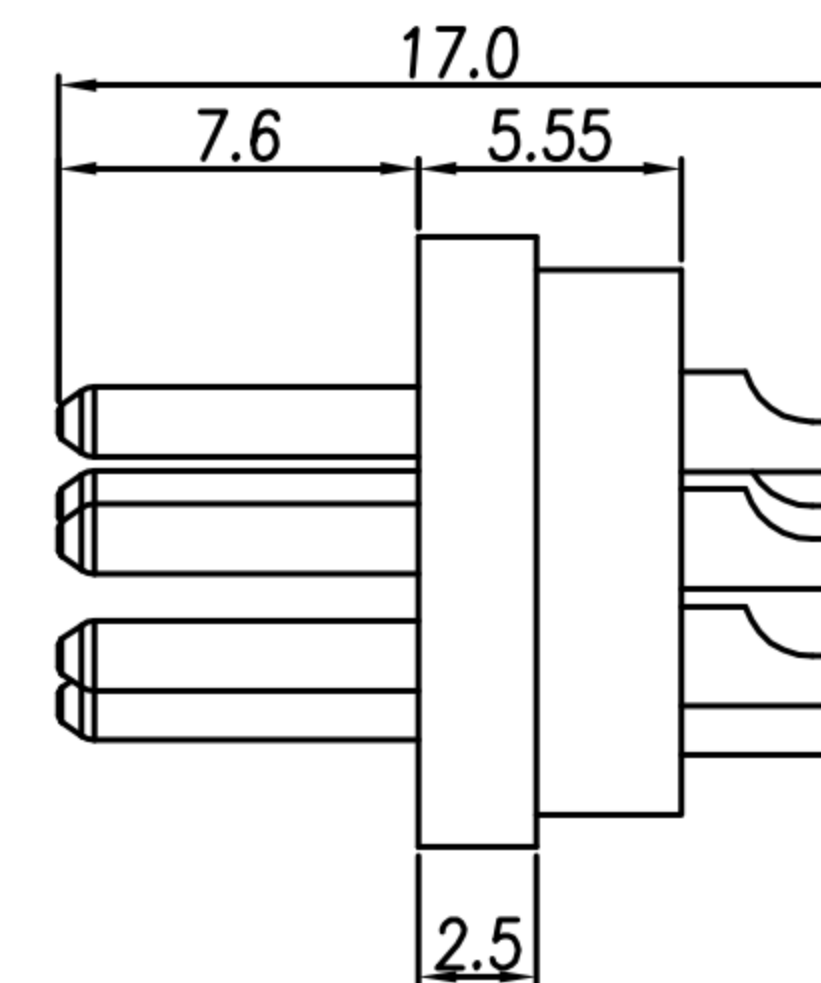
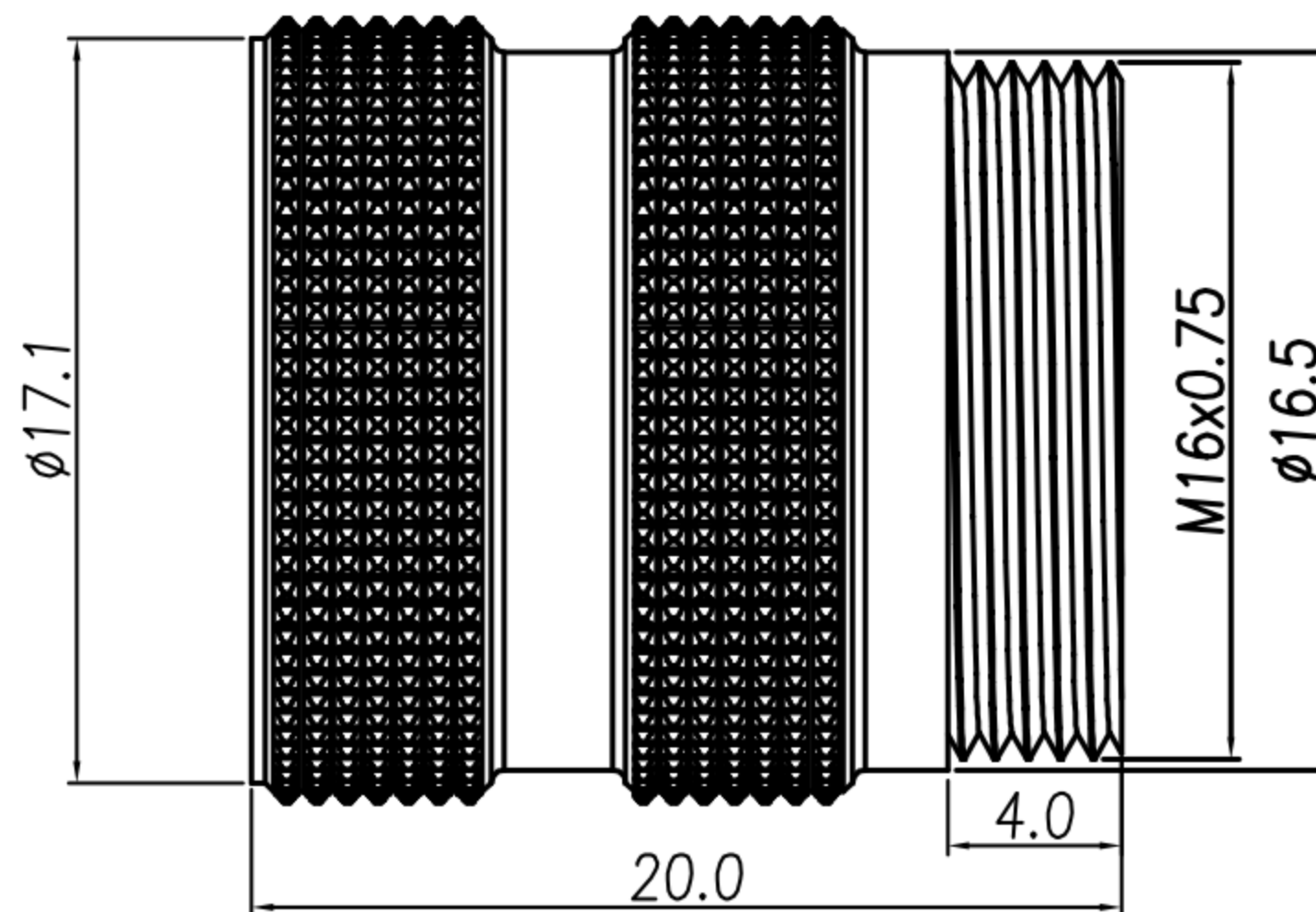
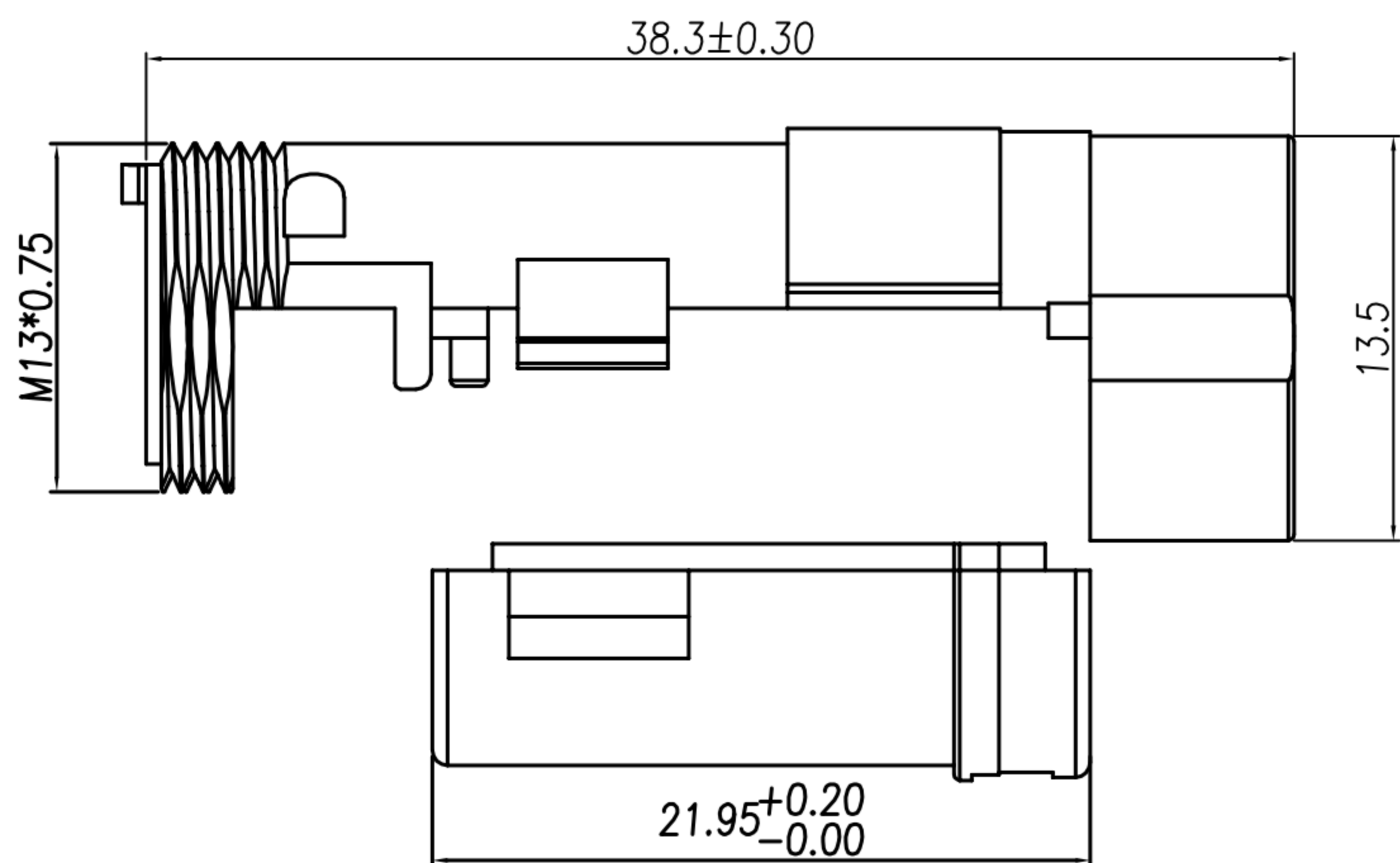

3P~8PIN尺寸

12PIN尺寸

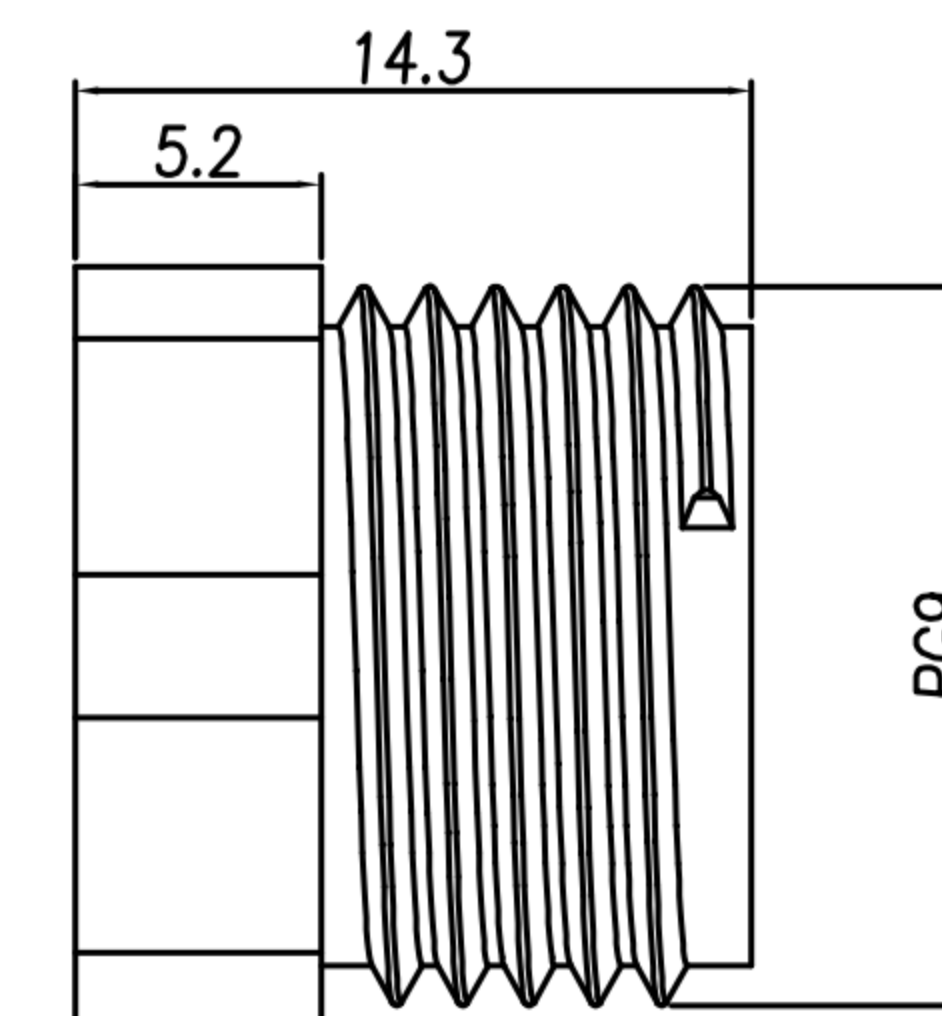
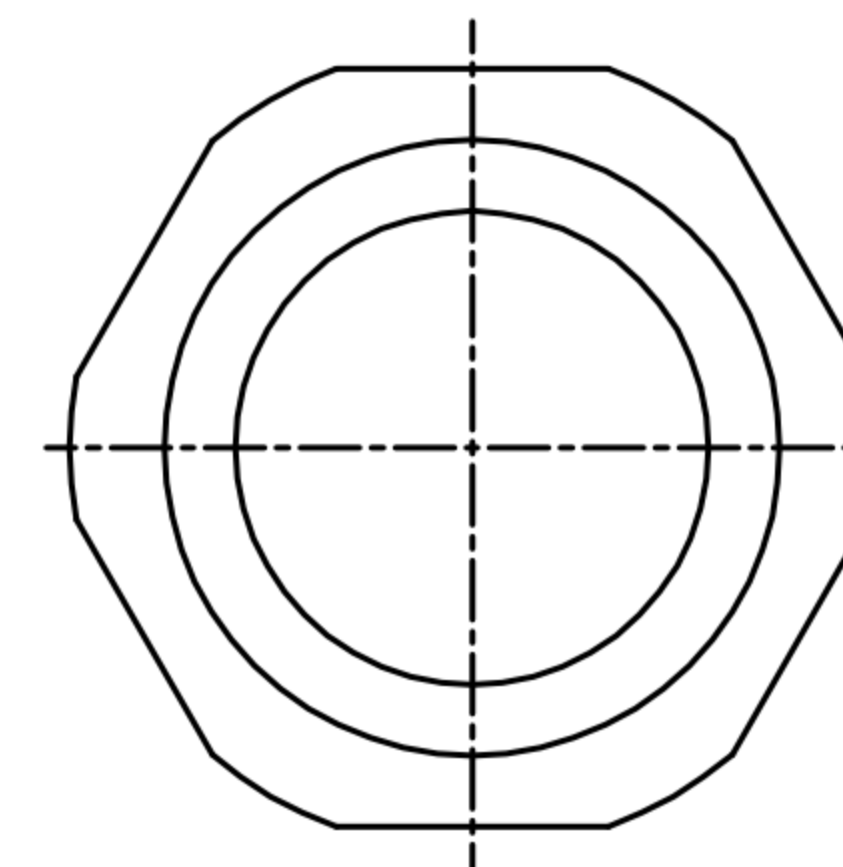
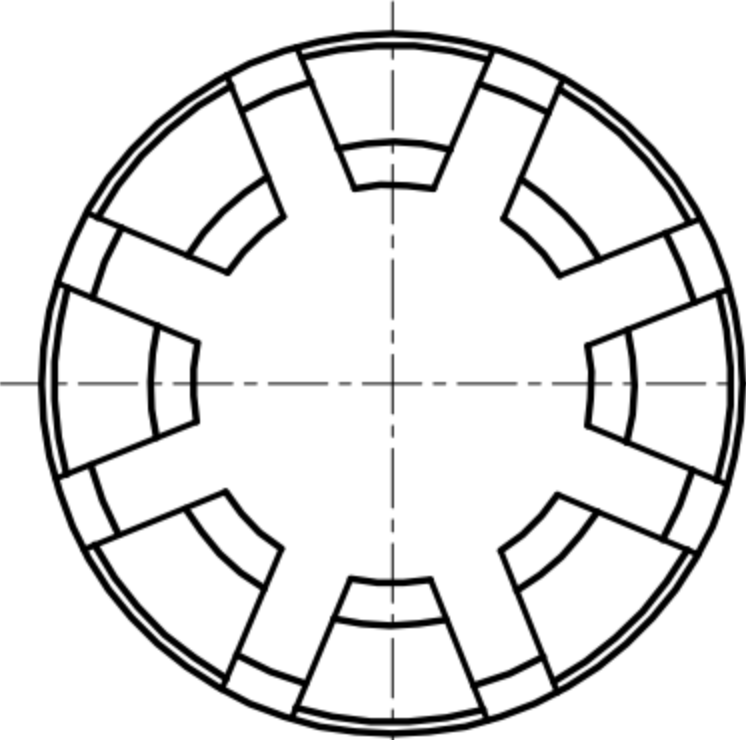
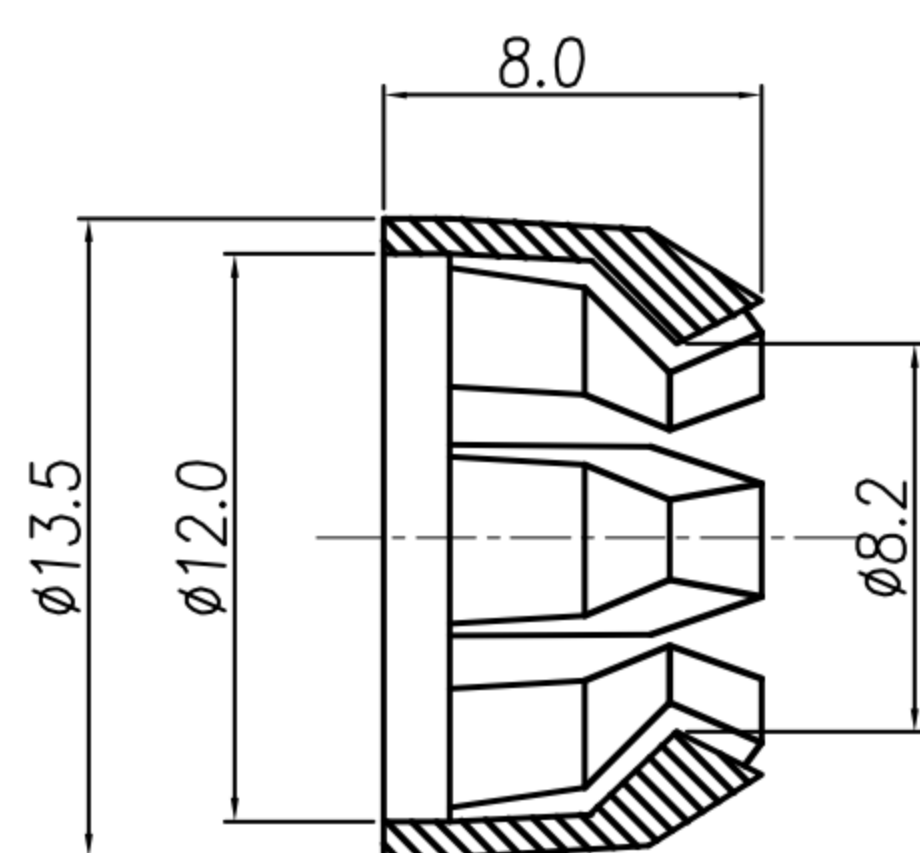
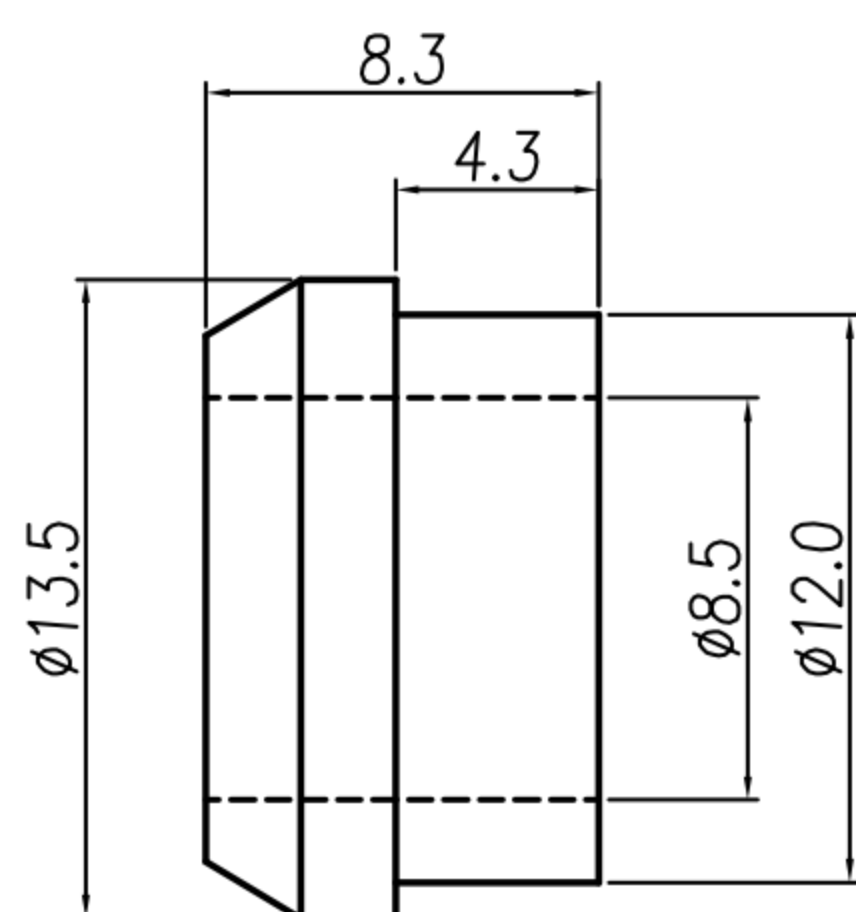
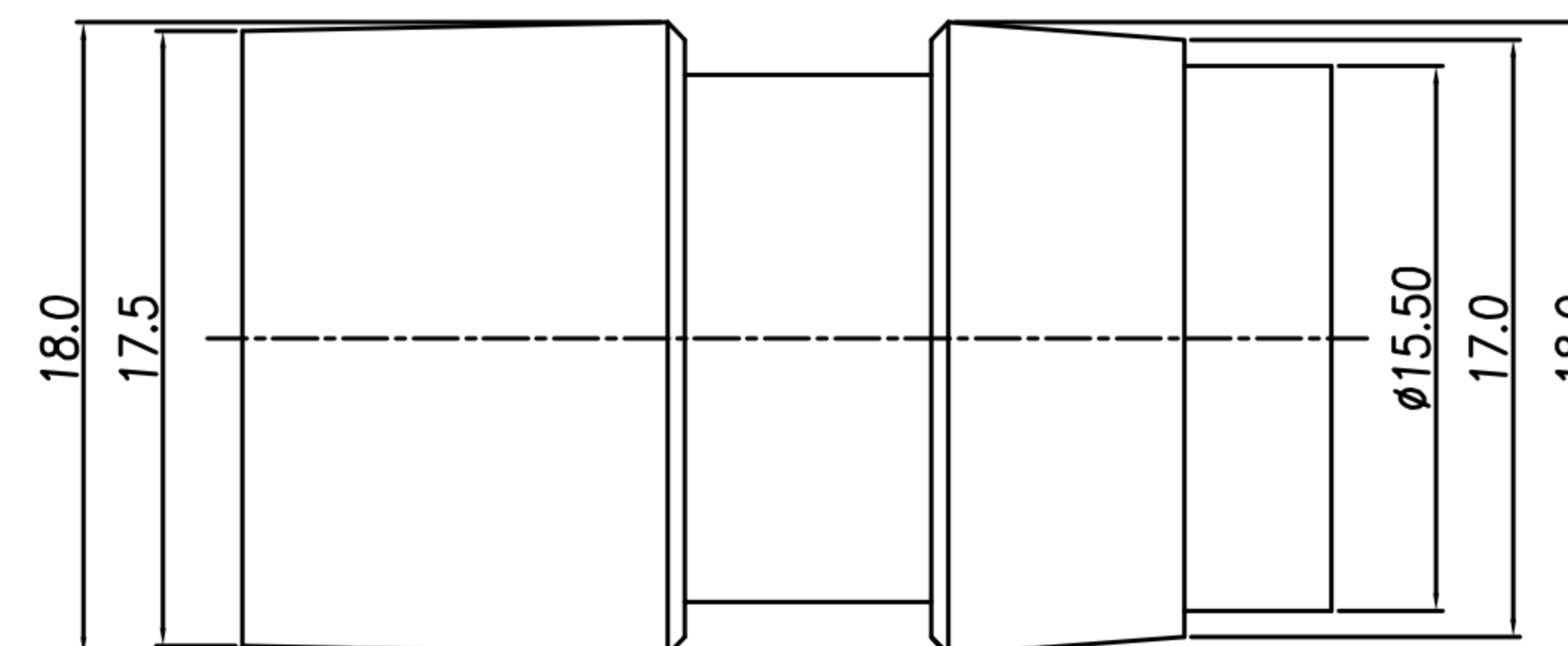
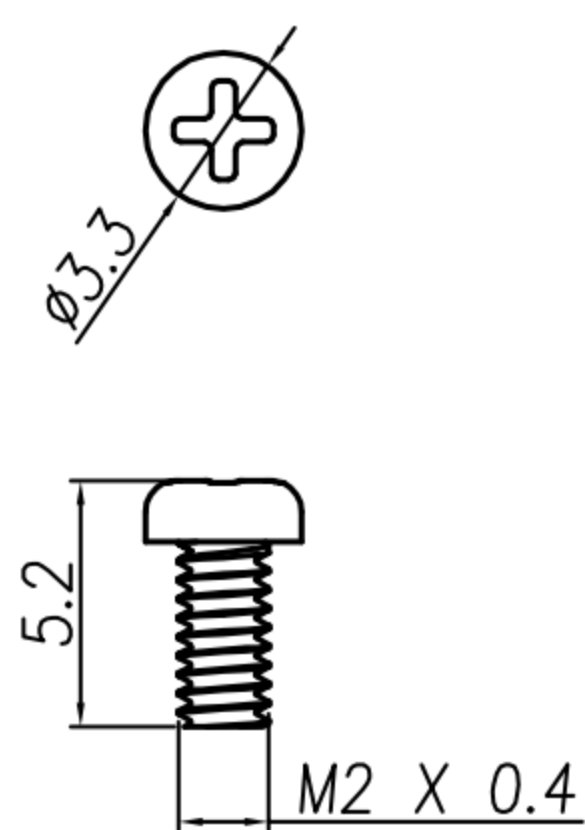
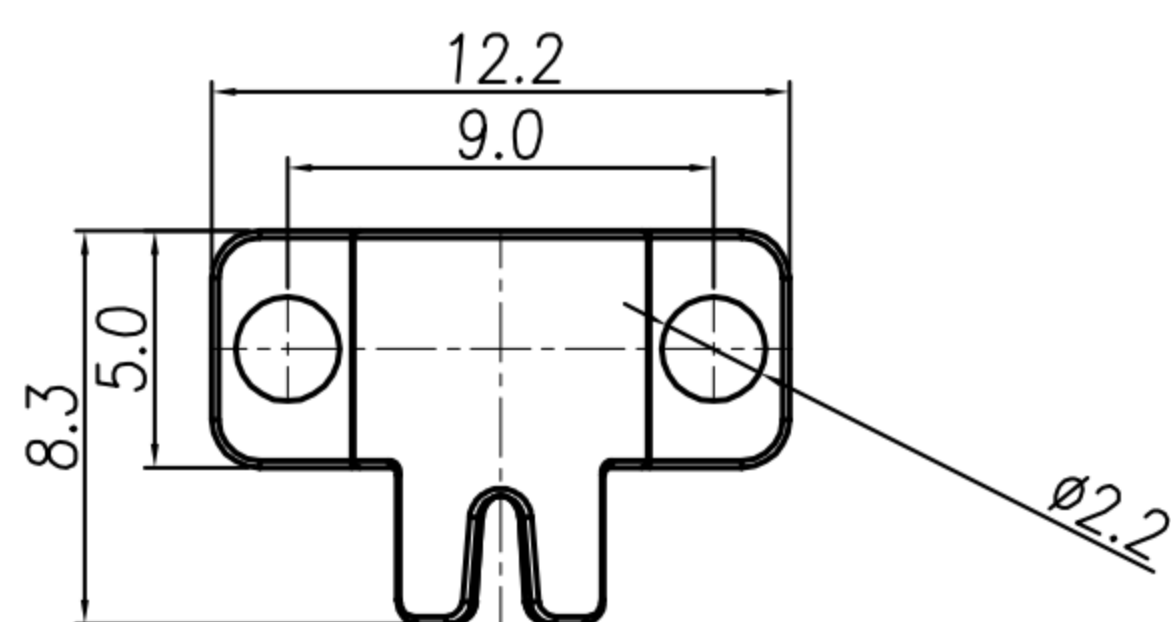
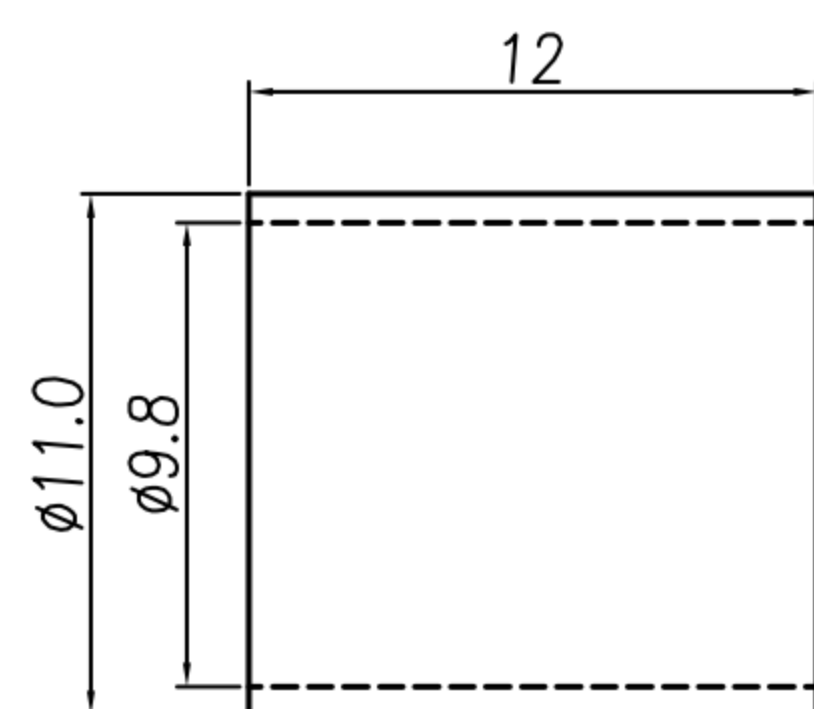

DRAWN	LED	APP'D	Ku Chou	UNIT	mm	TOLERANCE		广东科斯达电子科技有限公司 GUANG DONG KE SI DA ELECTRONIC TECHNOLOGY CO., LTD.	TITLE	DIN (M) Assembly type			SHEET
CHK'D	Emily Suen			SCALE	1:1	.x ±0.20 .xx ±0.10 .xxx ±0.05 .xxxx ±0.03 ANGULA ±1°			PART NO.	SEE TABLE A	DWG NO.	QC9242	VERSION

3/3
A

CUSTOMER DRAWING

REV.	DESCRIPTION	APPROVED BY	DATE	ECN NO.
△A				
△B				
△C				

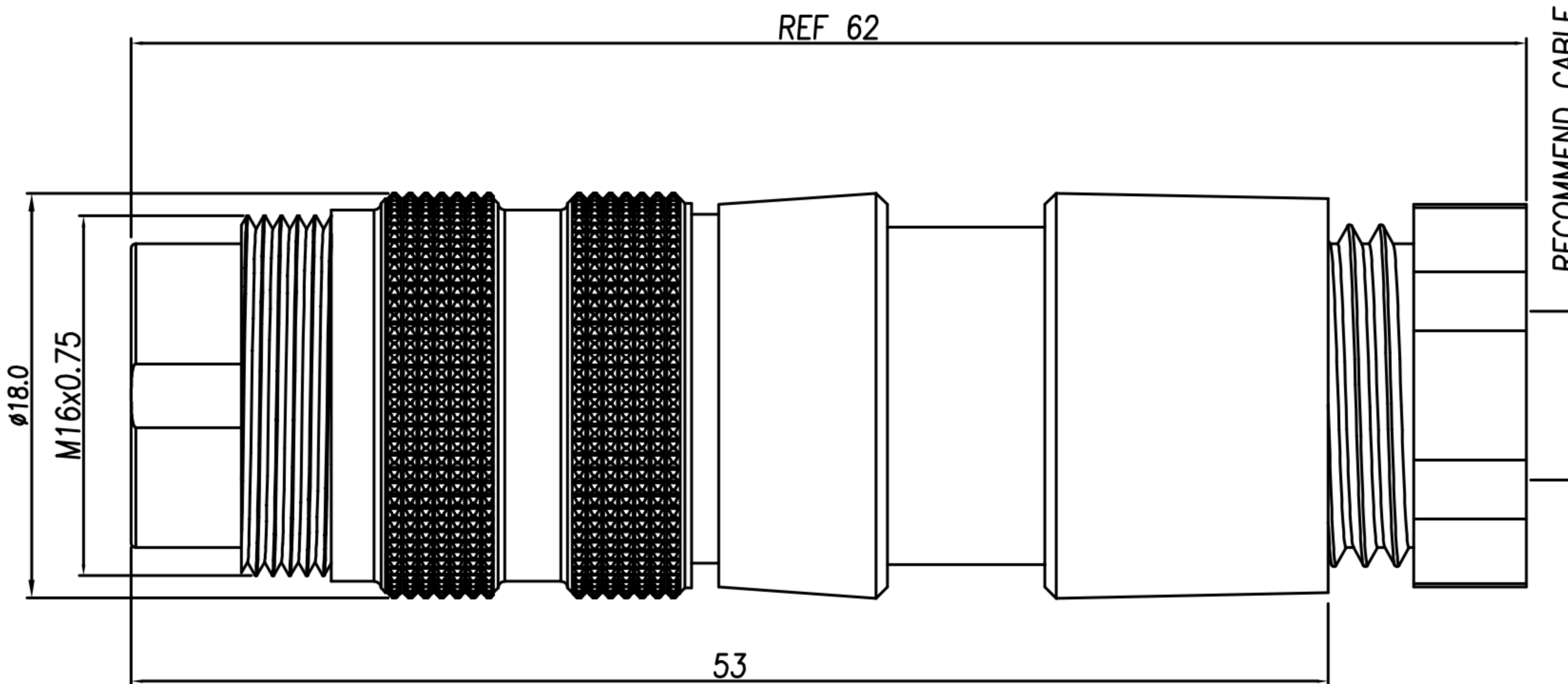
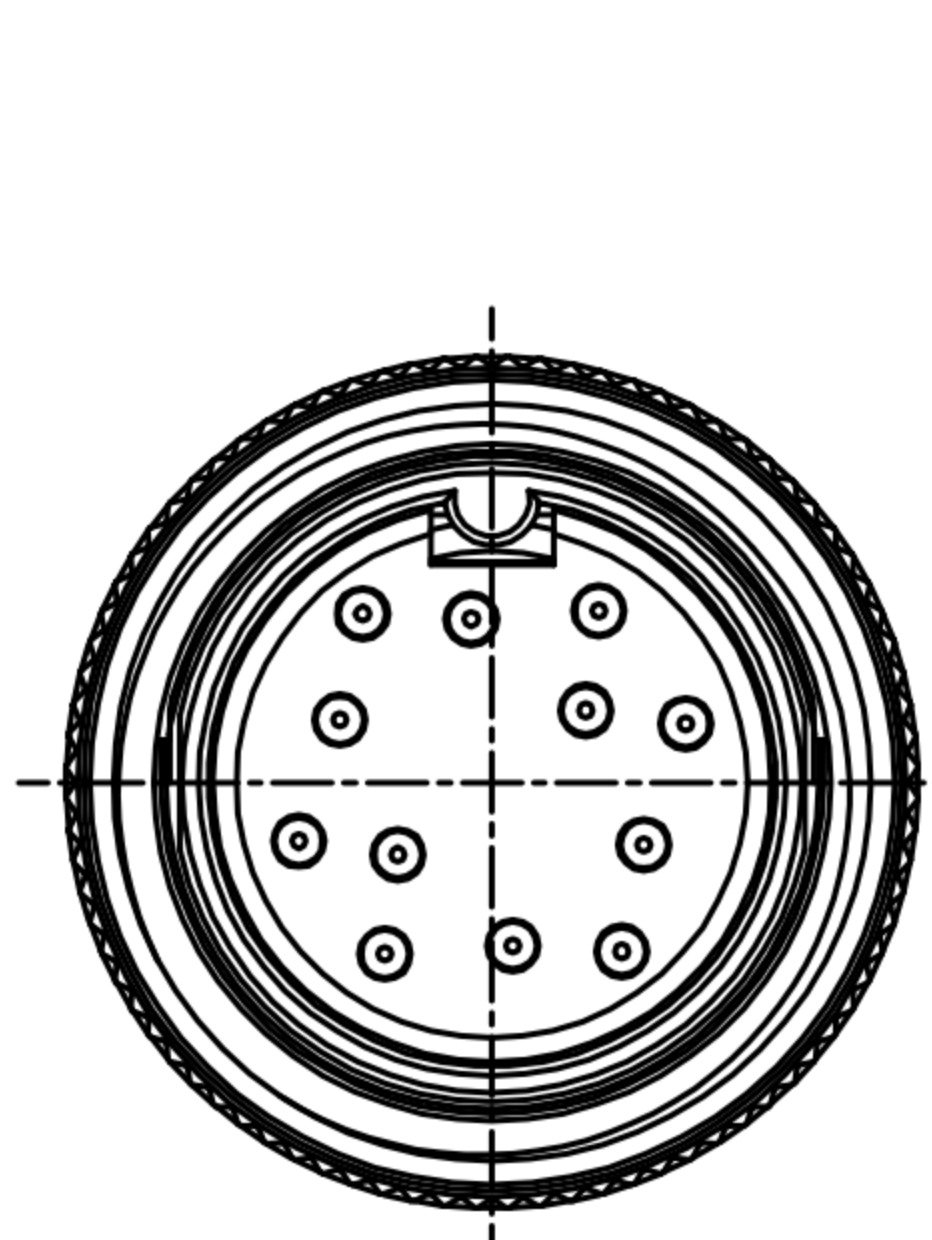

RECOMMEND CABLE OD=6mm~8mm

- MATERIAL :
 - 1-1. HOUSING : NYLON UL94V-0 ; COLOR : BLACK
 - 1-2. CONTACT : BRASS.
 - 1-3. CLAMPS BODY : ZINC ALLOY
 - 1-4. CAP : ZINC ALLOY
 - 1-5. ISOLATION : PVC
 - 1-6. CLAMPS : ZINC ALLOY
 - 1-7. SCREW : SPCC
 - 1-8. COAT : BRASS
 - 1-9. BACK BODY : NYLON+GF15% UL94V-0;COLOR:BLACK
 - 1-10. GLAND : SILICONE COLOR : BLACK
 - 1-11. GLAND CAGE : POM;COLOR:WHITE
 - 1-12. GLAND NUT : NYLON+GF15% UL94V-0;COLOR:BLACK
- FINISH :
 - 2-1. CONTACT : GOLD FLASH MICRO INCHES MIN.
 - 2-2. CLAMPS BODY : NICKEL PLATED
 - 2-3. CAP: NICKEL PLATED
 - 2-4. CLAMPS: NICKEL PLATED
 - 2-5. SCREW : NICKEL PLATED
 - 2-6. COAT : NICKEL PLATED
- ELECTRICAL SPECIFICATION :
 - 3-1. Rated current : 3PIN~8PIN 5A ; 12PIN 3A
 - 3-2. Rated Voltage : 3PIN~8PIN 250V ; 12PIN 60V
 - 3-3. Water proof : IP40
- Environmental :
 - 4-1. Operation Temperature : -20 ℃~85℃

DI-03M2-14-11	DI-04M2-23-11	DI-05M2-20-11	DI-05M2-22-11	DI-06M2-21-11	DI-07M2-21-11	DI-07M2-20-11	DI-08M2-22-11	DI-12M2-15-11

DRAWN	LED	APP'D	Ku Chou	UNIT	mm	TOLERANCE			广东科斯达电子科技有限公司 GUANG DONG KE SI DA ELECTRONIC TECHNOLOGY CO., LTD.	TITLE	DIN (M) Assembly type			SHEET
CHK'D	Emily Suen			SCALE	1:1					PART NO.	SEE TABLE A	DWG NO.	QC9242	VERSION

CUSTOMER DRAWING

REV.	DESCRIPTION	APPROVED BY	DATE	ECN NO.
△A				
△B				
△C				

ASSEMBLY INSTRUCTION

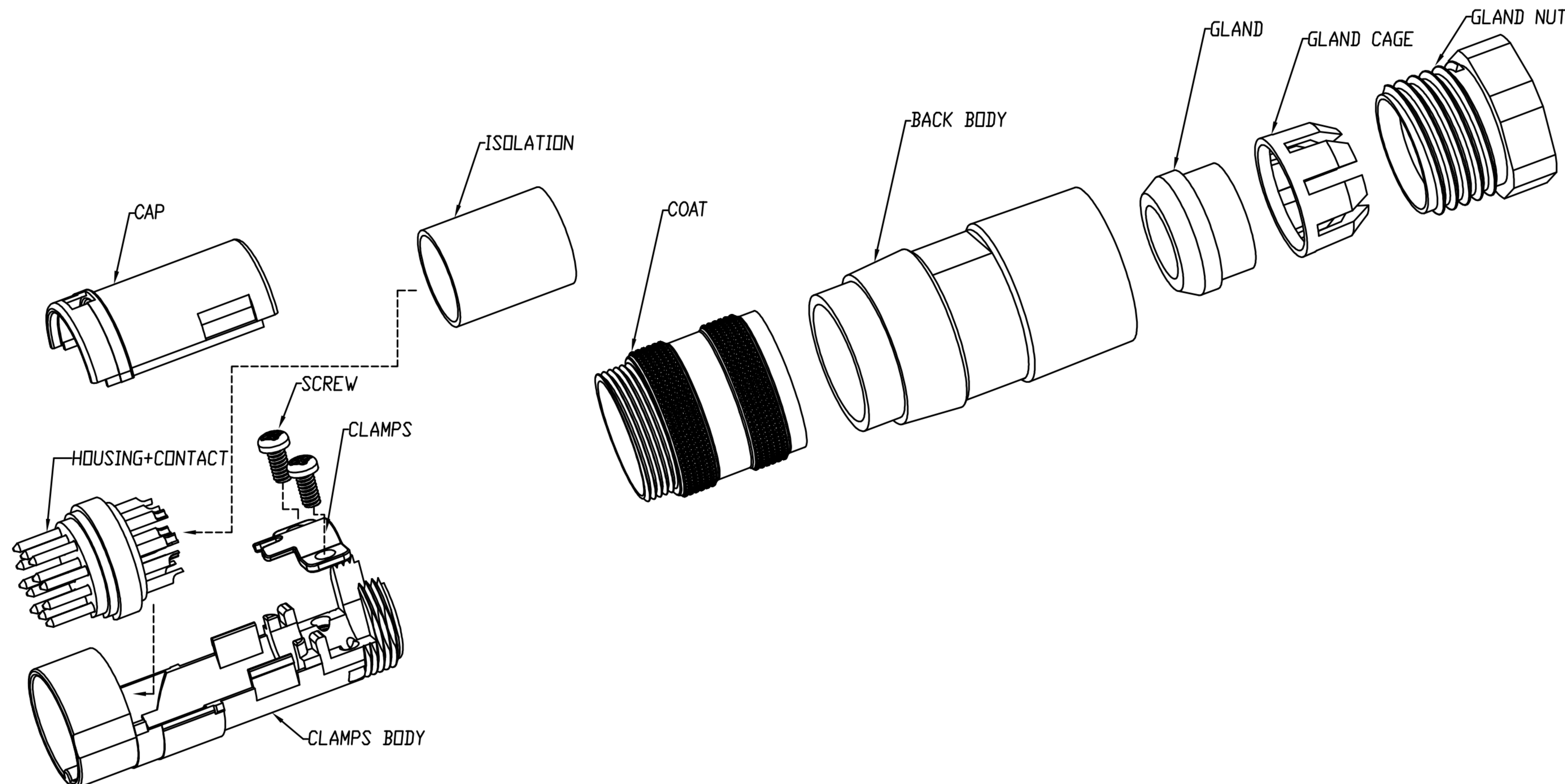

DRAWN	LED	APP'D	Ku Chou	UNIT	mm	TOLERANCE		广东科斯达电子科技有限公司 GUANG DONG KE SI DA ELECTRONIC TECHNOLOGY CO., LTD.	TITLE	DIN (M) Assembly type			SHEET
CHK'D	Emily Suen			SCALE	1:1	.x ±0.20 .xx ±0.10 .xxx ±0.05 .xxxx ±0.03 ANGULA ±1°			PART NO.	SEE TABLE A	DWG NO.	QC9242	
												VERSION	A