

CUSTOMER DRAWING

REV.	DESCRIPTION	APPROVED BY	DATE	ECN NO.
△A				
△B				
△C				

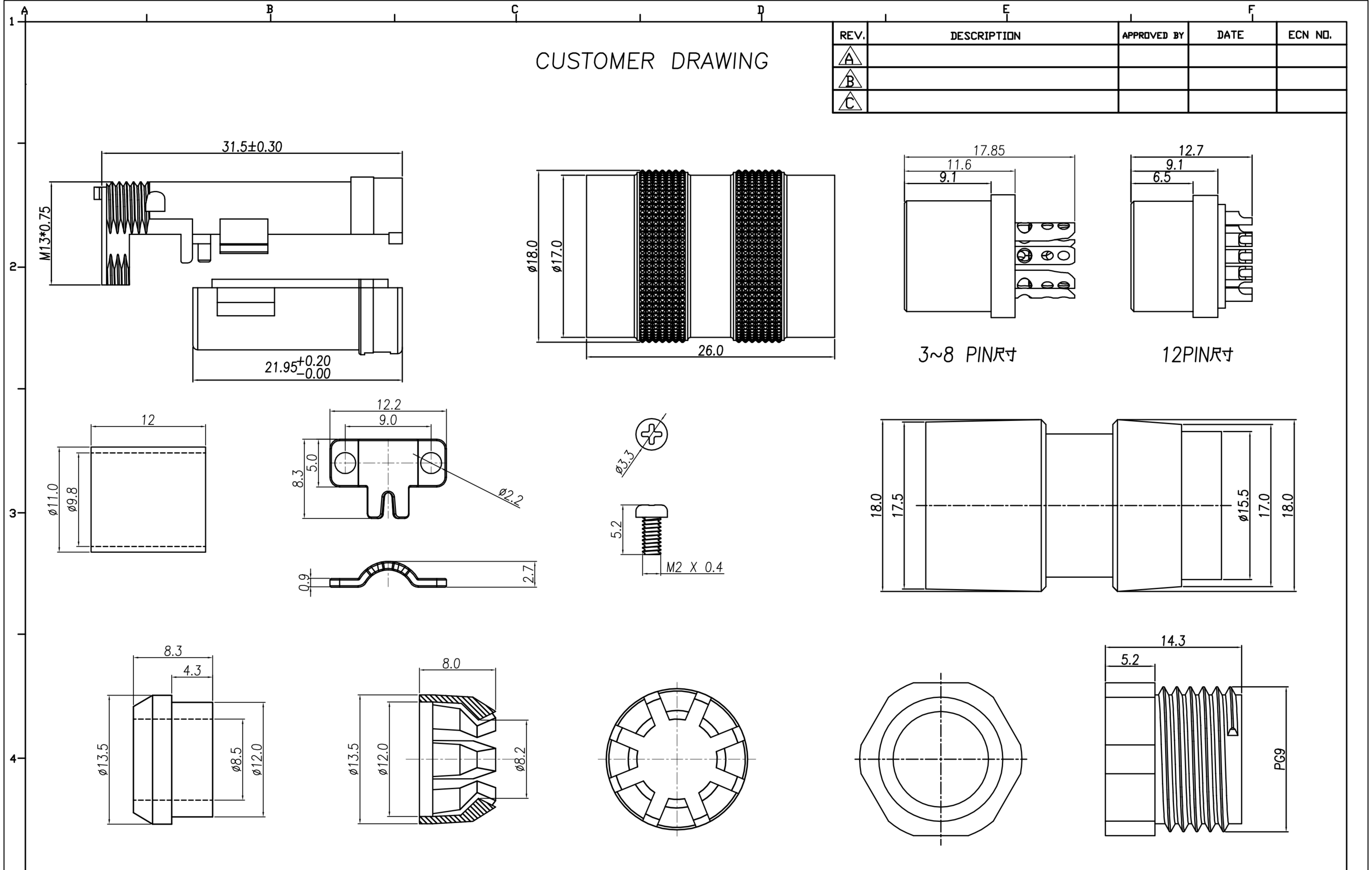

DRAWN	LED	APP'D	Ku Chou	UNIT	mm	TOLERANCE		广东科斯达电子科技有限公司 GUANG DONG KE SI DA ELECTRONIC TECHNOLOGY CO., LTD.	TITLE	DIN (F) Assembly type			SHEET
CHK'D	Emily Suen			SCALE	1:1	.x ±0.20 .xx ±0.10 .xxx ±0.05 .xxxx ±0.03 ANGULA ±1°			PART NO.	SEE TABLE A	DWG NO.	QC9187	VERSION

3/3  
A

# CUSTOMER DRAWING

REV.	DESCRIPTION	APPROVED BY	DATE	ECN NO.
△A				
△B				
△C				

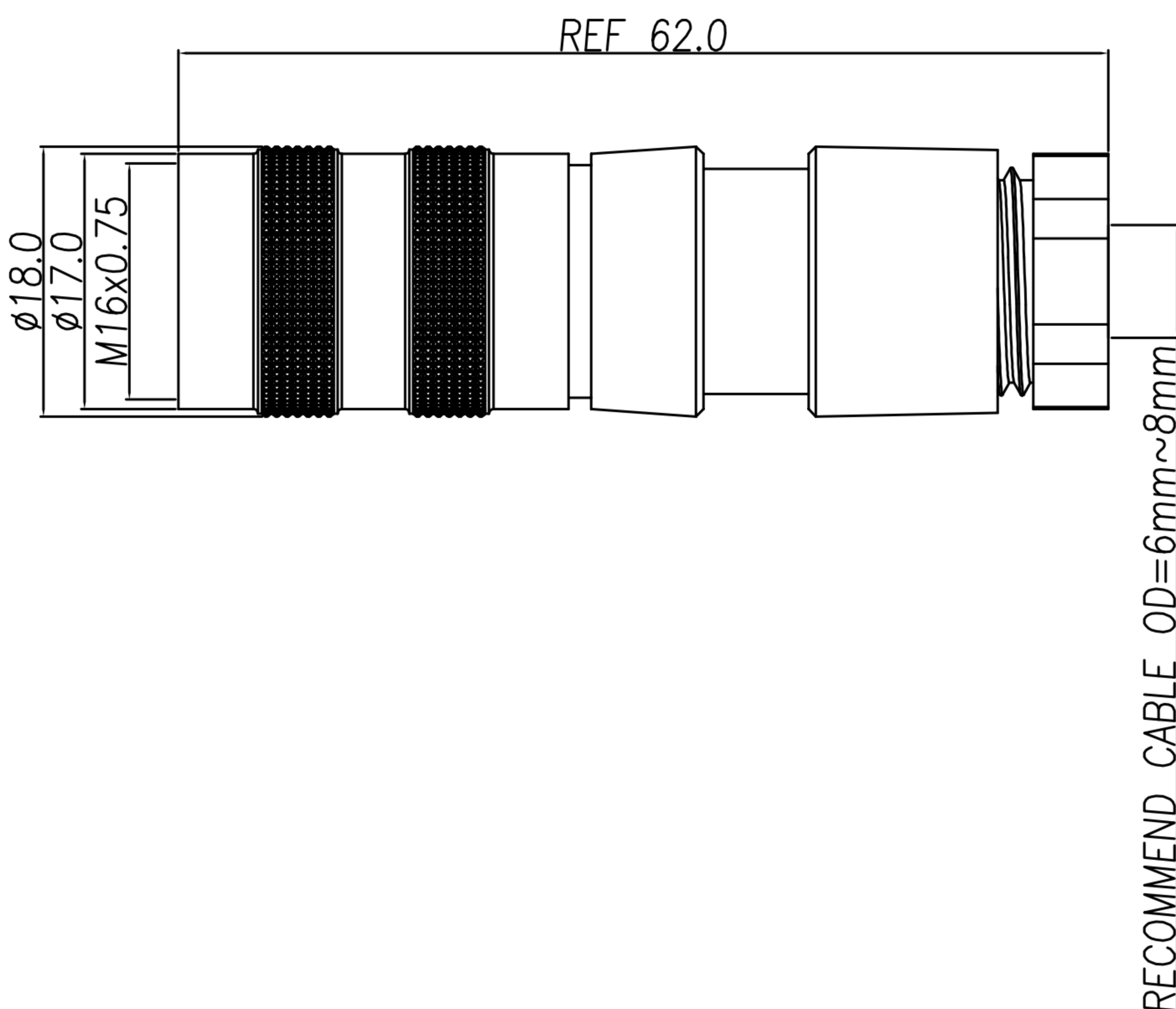
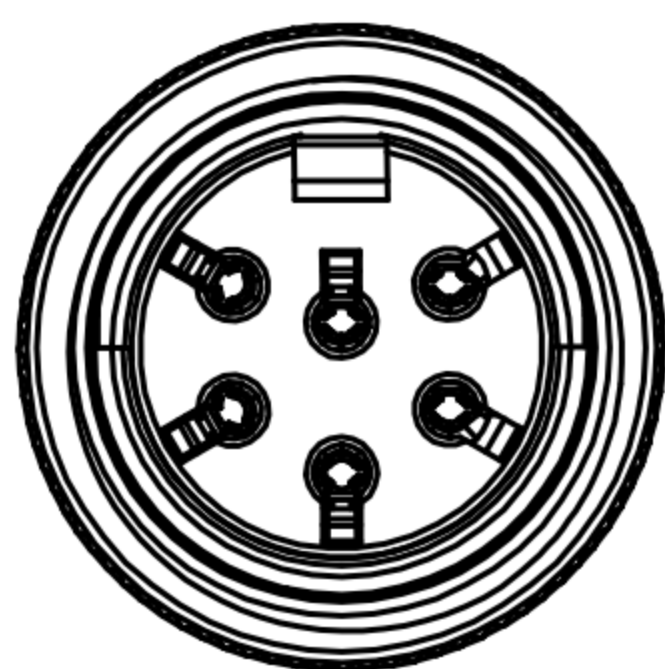

1. MATERIAL :
  - 1-1. HOUSING : NYLON UL94V-0 ; COLOR : BLACK
  - 1-2. CONTACT : 3~8PIN PHOSPHOR BRONZE;12PIN BRASS
  - 1-3. ISOLATION : PVC
  - 1-4. CAP : ZINC ALLOY
  - 1-5. CLAMPS : ZINC ALLOY
  - 1-6. CLAMPS BODY : ZINC ALLOY
  - 1-7. SCREW : SPCC
  - 1-8. COAT : BRASS
  - 1-9. BACK BODY : NYLON+GF15% UL94V-0;COLOR :BLACK
  - 1-10. GLAND : SILICONE COLOR : BLACK
  - 1-11. GLAND CAGE : POM ; COLOR : WHITE
  - 1-12. GLAND NUT : NYLON UL94V-0 ; COLOR : BLACK
2. FINISH :
  - 2-1. CONTACT : 3~8PIN:
    - CONTACT AREA : GOLD FLASH PLATING
    - SOLDER AREA : TIN
    - UNDER PLATE : NICKEL
  - 12PIN:
    - CONTACT : GOLD FLASH PLATED
  - 2-2. CAP: NICKEL PLATED
  - 2-3. CLAMPS : NICKEL PLATED
  - 2-4. CLAMPS BODY : NICKEL PLATED
  - 2-5. SCREW : NICKEL PLATED
  - 2-6. COAT: NICKEL PLATED
3. ELECTRICAL SPECIFICATION :
  - 3-1. Rated current :3PIN~8PIN 5A ; 12PIN 3A
  - 3-2. Rated Voltage :3PIN~8PIN 250V ;12PIN 60V
  - 3-3. Water proof : IP40
4. Environmental :
  - 4-1. Operation Temperature : -20 ℃~85℃

DI-03F2-14-11	DI-04F2-20-11	DI-05F2-17-11	DI-05F2-21-11	DI-06F2-25-11	DI-07F2-17-11	DI-07F2-24-11	DI-08F2-15-11	DI-12F2-14-11

DRAWN	LED	APP'D	Ku Chou	UNIT	mm	TOLERANCE		广东科斯达电子科技有限公司 GUANG DONG KE SI DA ELECTRONIC TECHNOLOGY CO., LTD.	TITLE	DIN (F) Assembly type			SHEET
CHK'D	Emily Suen			SCALE	1:1	.x ±0.20 .xx ±0.10 .xxx ±0.05 .xxxx ±0.03 ANGULA ±1°			PART NO.	SEE TABLE A	DWG NO.	QC9187	VERSION

CUSTOMER DRAWING

REV.	DESCRIPTION	APPROVED BY	DATE	ECN NO.
△A				
△B				
△C				

ASSEMBLY INSTRUCTION

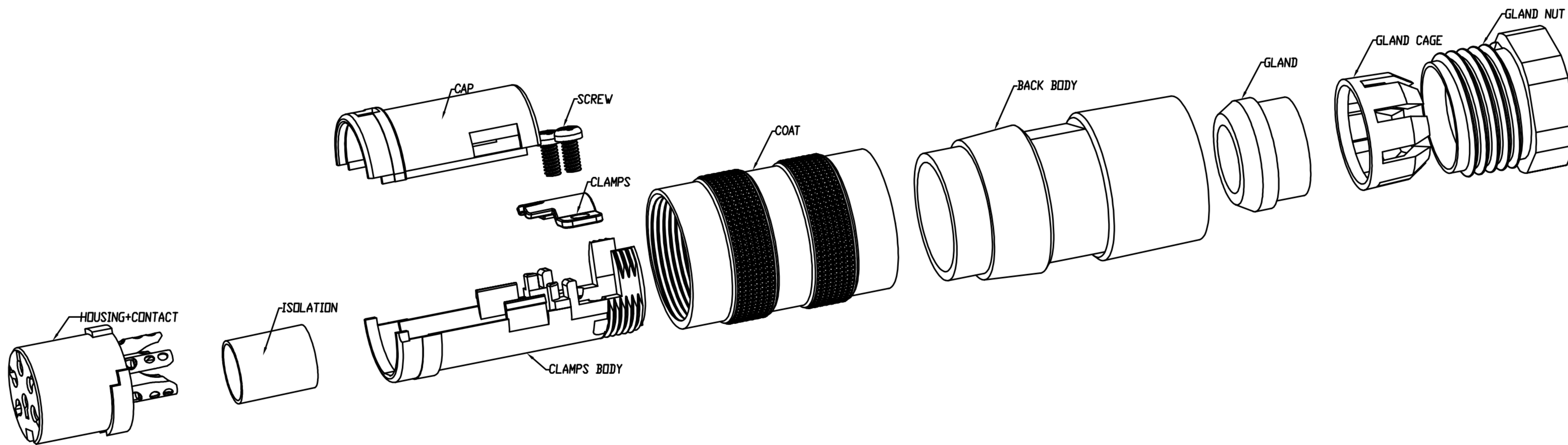

DRAWN	LED	APP'D	Ku Chou	UNIT	mm	TOLERANCE		广东科斯达电子科技有限公司 GUANG DONG KE SI DA ELECTRONIC TECHNOLOGY CO., LTD.	TITLE	DIN (F) Assembly type			SHEET
CHK'D	Emily Suen			SCALE	1:1	.x ±0.20 .xx ±0.10 .xxx ±0.05 .xxxx ±0.03 ANGULA ±1°			PART NO.	SEE TABLE A	DWG NO.	QC9187	VERSION