

CUSTOMER DRAWING

REV.	DESCRIPTION	APPROVED BY	DATE	ECN NO.
△A	RELEASE	Yeh	20/07/20"	
△B				
△C				

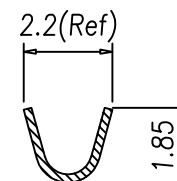

SECTION A-A

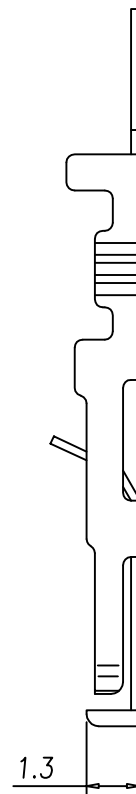
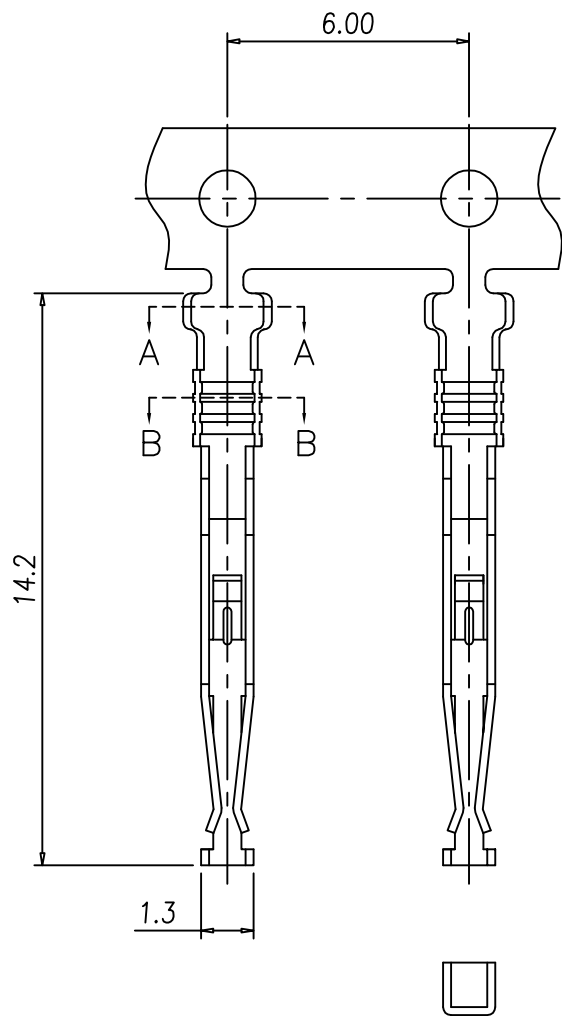
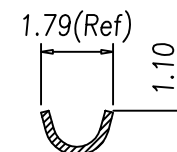

SECTION B-B

NOTE:

- 1. MATERIAL : PHOSPHOR BRONZE / 磷青銅
- 2. FINISH : SEE TABLE A
- UNDER PLATE : NICKEL PLATED 60u" ~ 100u" OVER ALL

TABLE A / 表A

OY-DM0835-10	GOLD FLASH PLATED / 鍍表金
OY-DM0819-10	BRIGHT TIN 60u" PLATED / 鍍亮錫60u"

DRAWN	Yeh Chou	APP'D	Emily Suen	UNIT	mm	TOLERANCE		广东科斯达电子科技有限公司 GUANG DONG KE SI DA ELECTRONIC TECHNOLOGY CO., LTD.	TITLE	MINI DIN (F) 雙耳鎖板式 CRIMP PIN			SHEET	A
CHK'D	Emily Suen			SCALE	1:1	.x ±0.10 .xx ±0.05 .xxx ±0.03 .xxxx ±0.01 ANGULA ±1°			PART NO.	SEE TABLE A	DWG NO.	QC9513	VERSION	