

# CUSTOMER DRAWING

REV.	DESCRIPTION	APPVL. BY	DATE	ECN NO.
C	CHANGE TOLERANCE.	Stewart	01/18/07'	
D	P.C.B.LAYOUT CHANGE	Stewart	25/03/08'	
E	增加生產注意事項	Fido Weng	26/05/08'	ECN09086
F	取消生產注意事項	Fido Weng	12/10/09'	
G	P. C. B. LAYOUT CHANGE	Fido Weng	03/11/10'	

### 步驟一:

1. 將成品一一放入包裝盤內, 依同一方向置入.
2. 包裝方式, 如圖所示.
3. 一個包裝盤 700 pcs.

### 步驟二:

1. 一個紙箱可以裝 10 個包裝盤.
2. 每盤 700 pcs, 每箱 7000 pcs.
3. 將包裝盤放入防水袋中, 包裝完後再封箱.

### 步驟三:

1. 用膠帶將紙箱封實.
2. 將標籤貼於紙箱上.

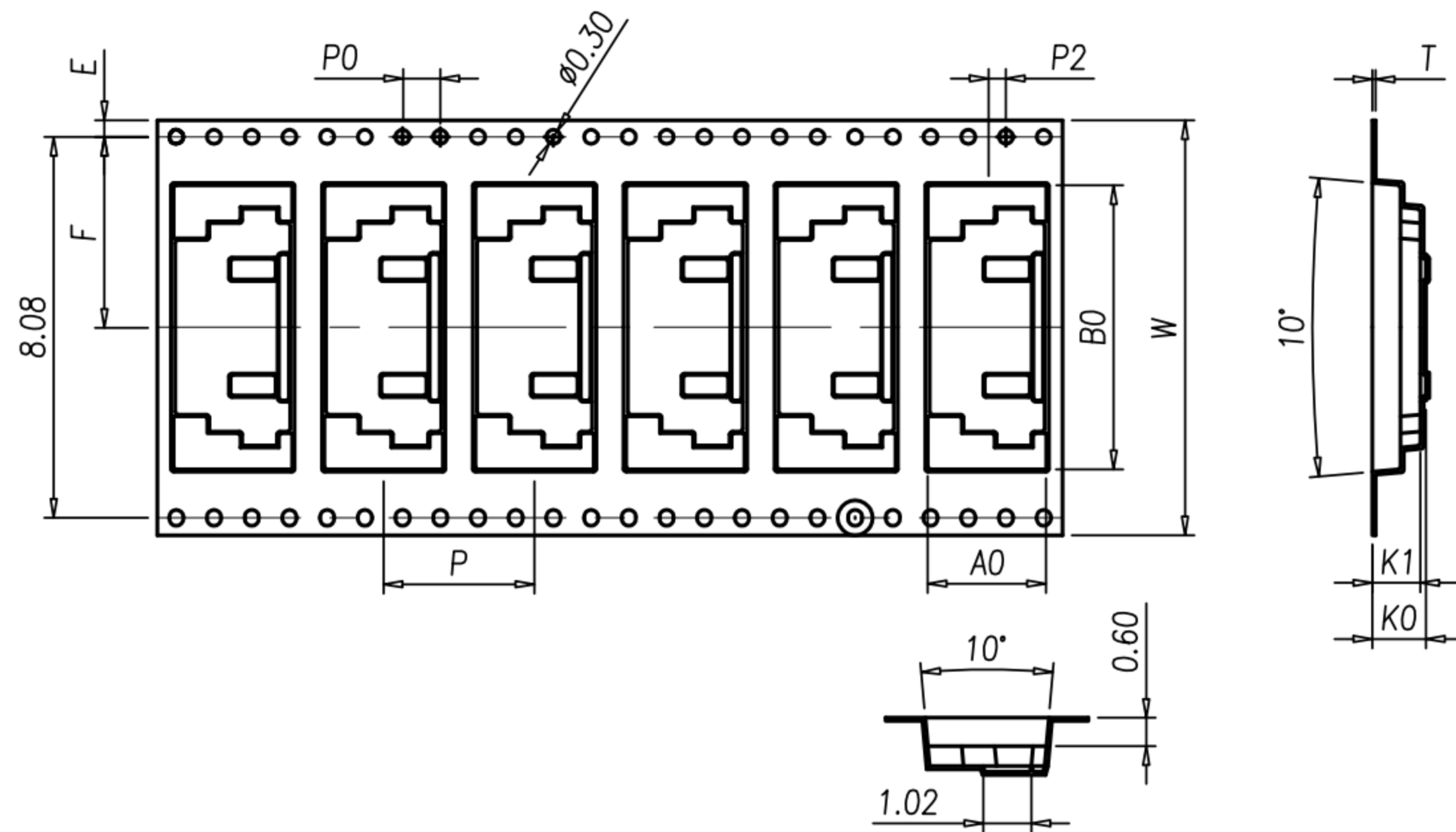
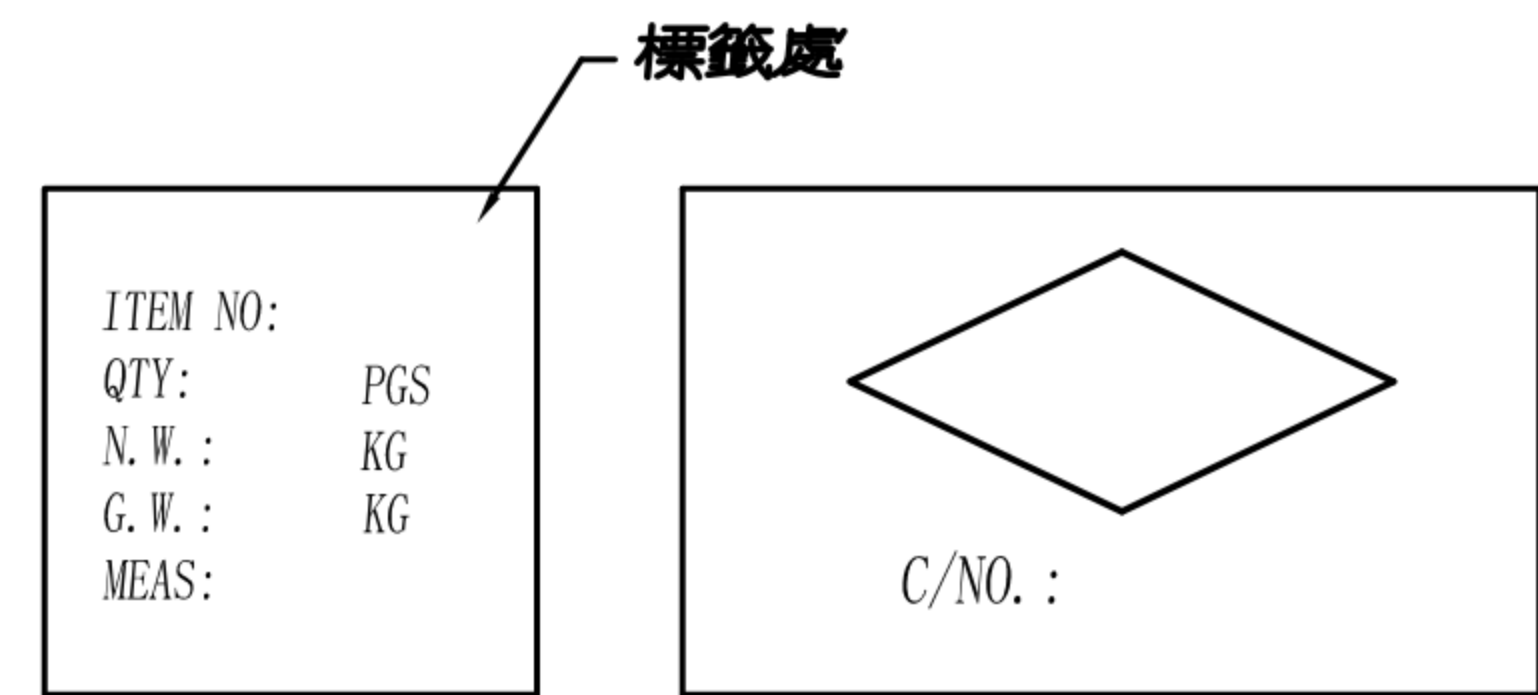
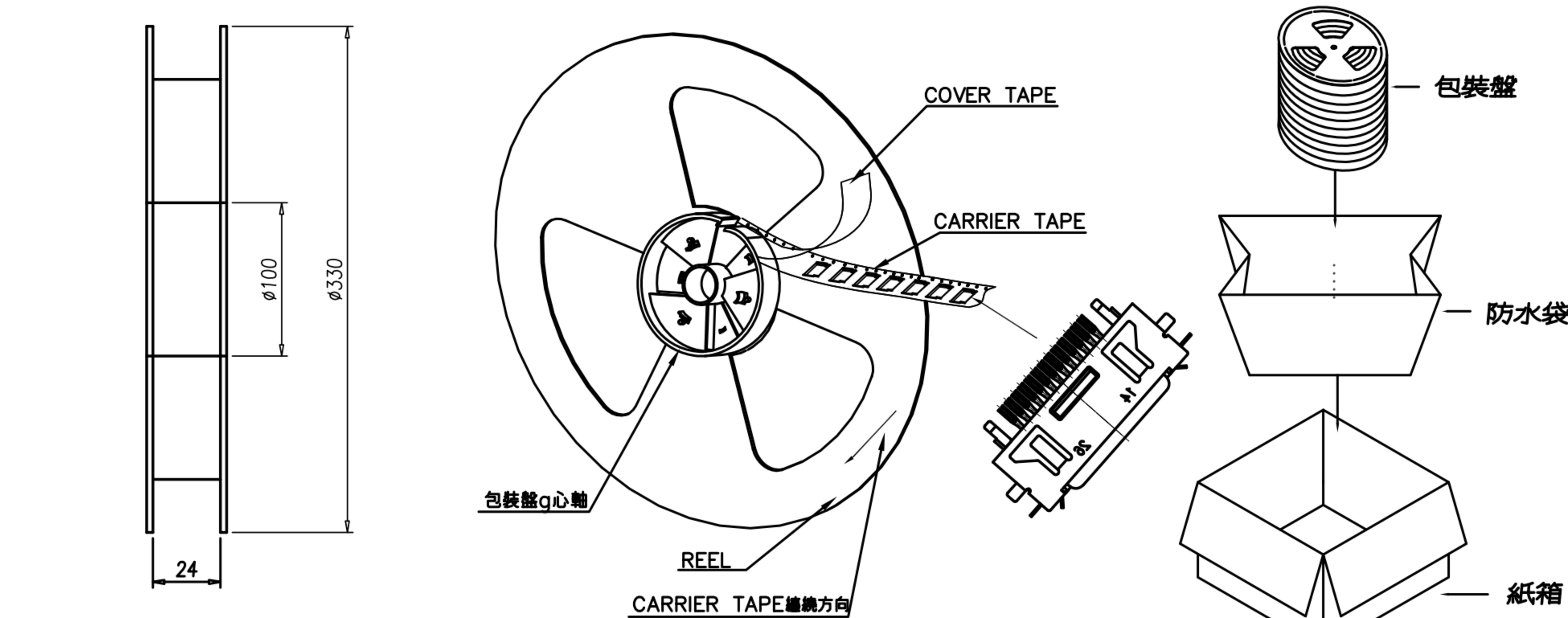

### NOTE:

1. 若有未裝滿之零數箱, 必須以緩衝材塞滿.
2. 在搬運過程中要輕拿輕放.
3. 載運輸中不可堆放過多, 不可有重壓現象.
4. 在裝滿產品後, 必須空留帶前和帶後 15 格以上, 然後用紙膠布貼上.
5. 上帶在貼下帶時必須平整, 且黏貼處不要出現氣泡.

ITEM	W	A0	B0	K0	K1	P	F	E	D0	D1	P0	P2	T
DIM	44.0 +0.30 -0.30	122 +0.10 -0.10	30.1 +0.10 -0.10	5.7 +0.10 -0.10	5.1 +0.10 -0.10	16.0 +0.10 -0.10	20.2 +0.10 -0.10	1.75 +0.10 -0.10	1.5 +0.10 -0.00	0.00 +0.25 -0.00	4.0 +0.10 -0.10	2.0 +0.10 -0.10	0.4 +0.05 -0.05

DRAWN	Mark Kao	APP'D	Ku Chou	UNIT	mm	TOLERANCE			TITLE	PCMCIA 26PIN A TYPE (F)			SHEET	
CHK'D	Emily Suen			SCALE	1:1	.x ±0.20 .xx ±0.10 .xxx ±0.05 .xxxx ±0.03 ANGULA ±1°			PART NO.	TABLE A	DWG NO.	QC0615	VERSION	

CUSTOMER DRAWING

REV.	DESCRIPTION	APPVL. BY	DATE	ECN NO.
C	CHANGE TOLERANCE.	Stewart	01/18/07'	
D	P.C.B.LAYOUT CHANGE	Stewart	25/03/08'	
E	增加生產注意事項	Fido Weng	26/05/08'	ECN09086
F	取消生產注意事項	Fido Weng	12/10/09'	
G	P. C. B. LAYOUT CHANGE	Fido Weng	03/11/10'	

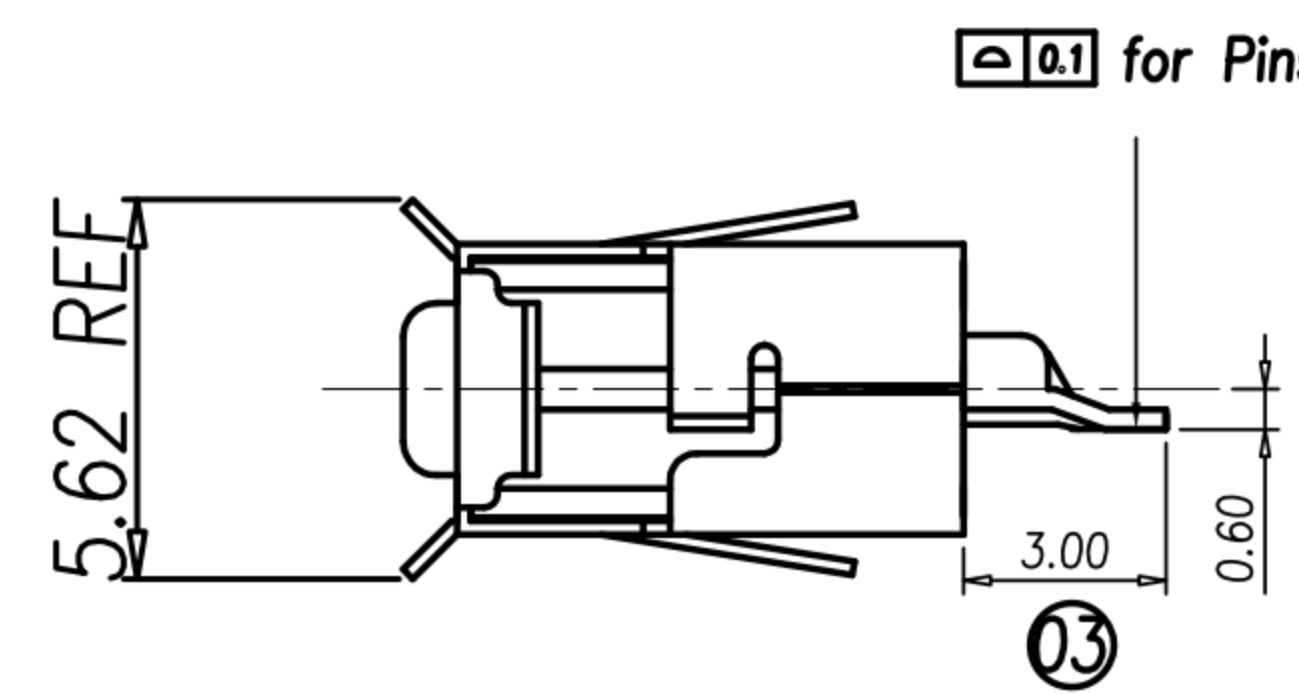
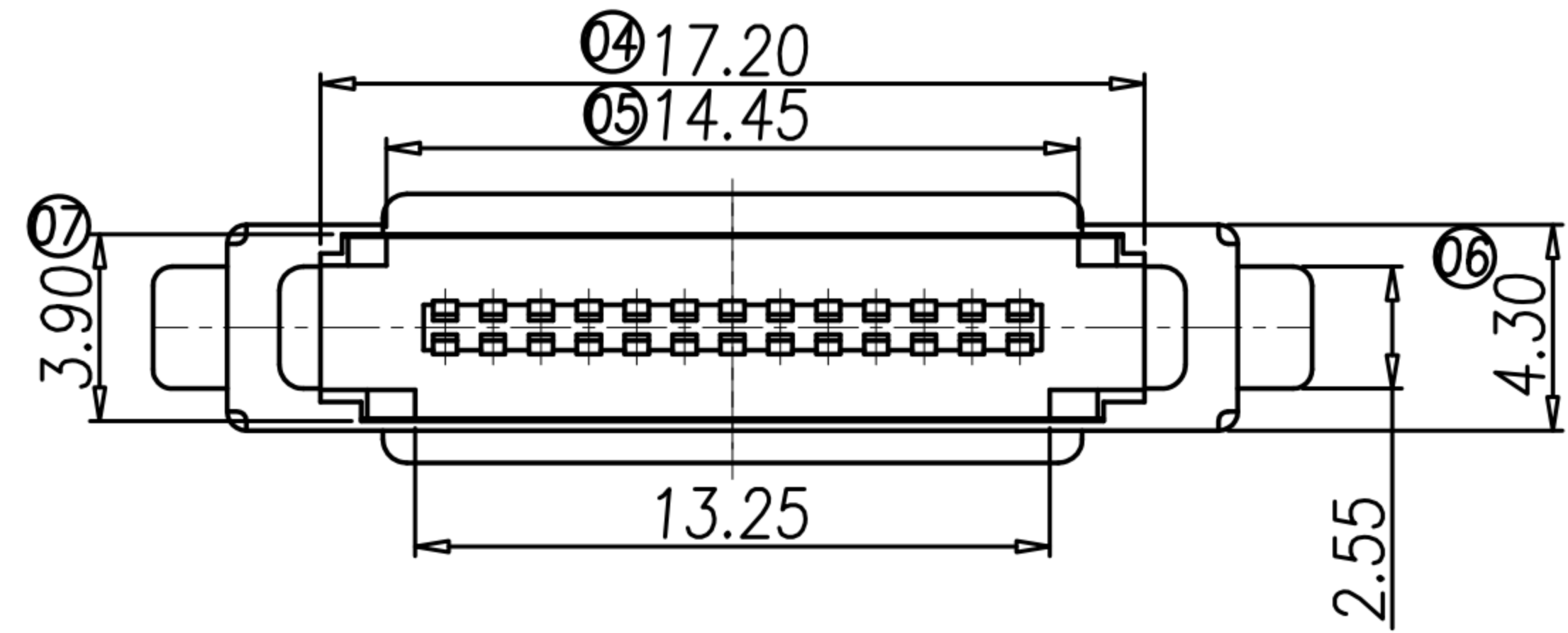
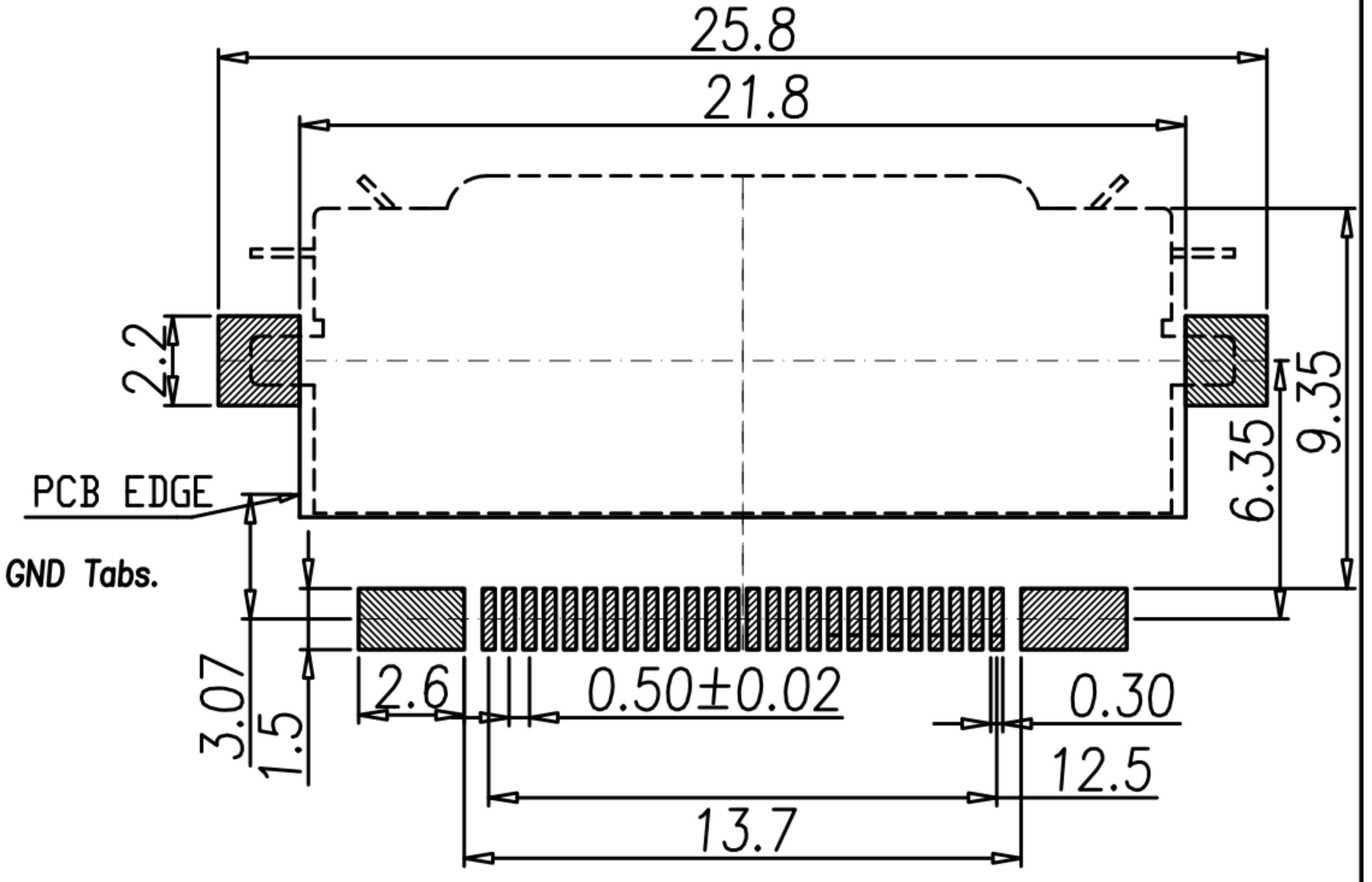
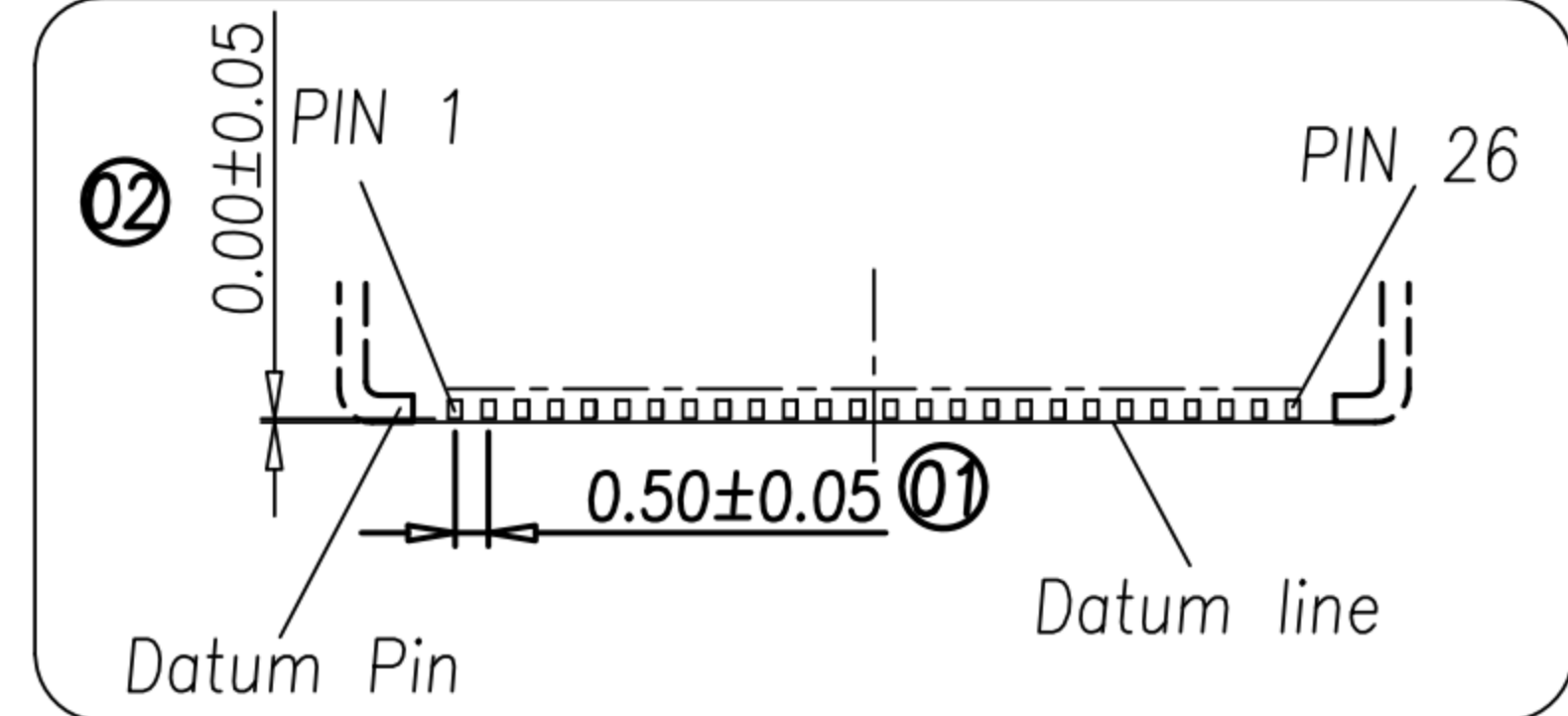
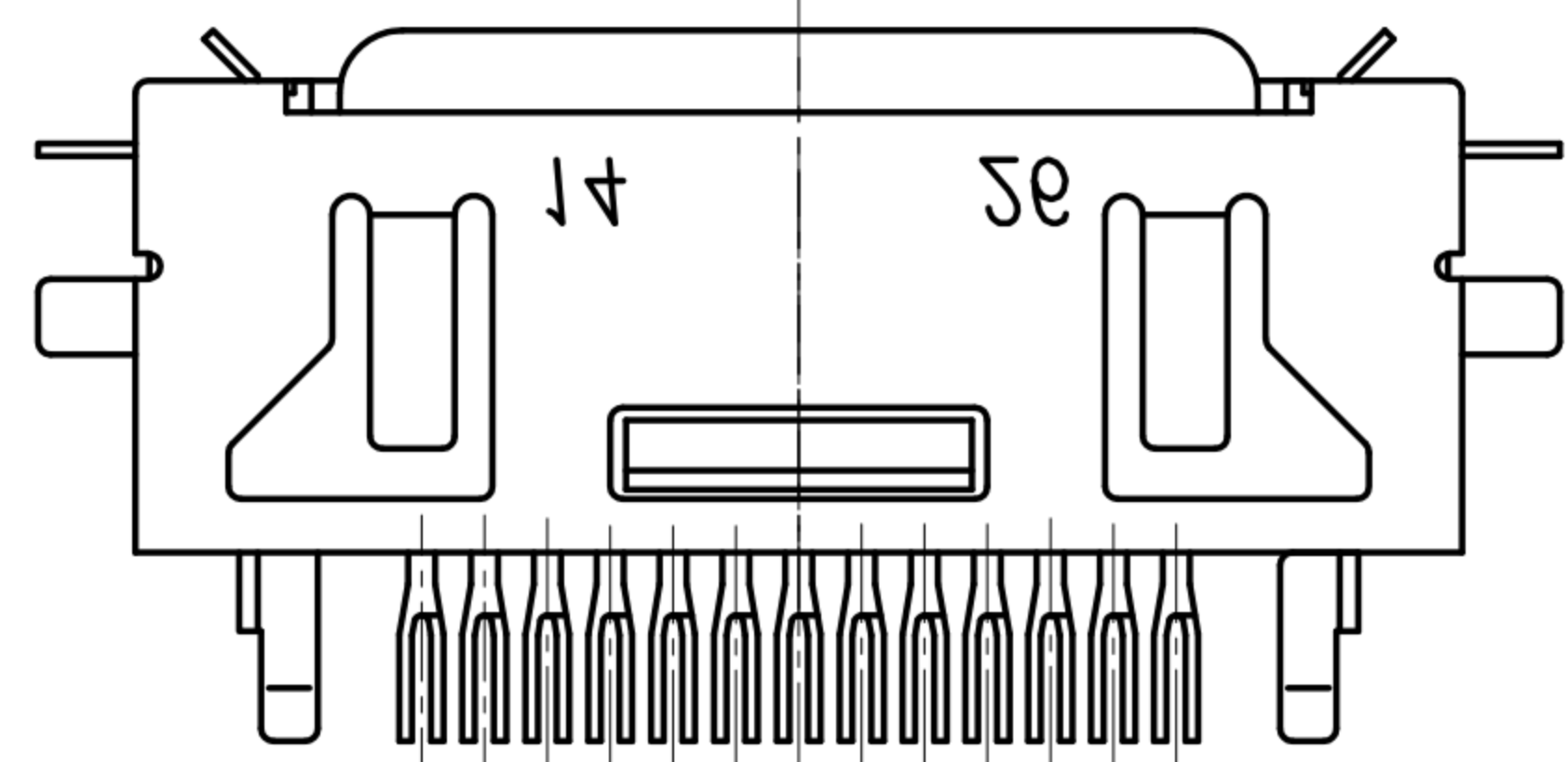

RECOMMEND P.C.B LAYOUT

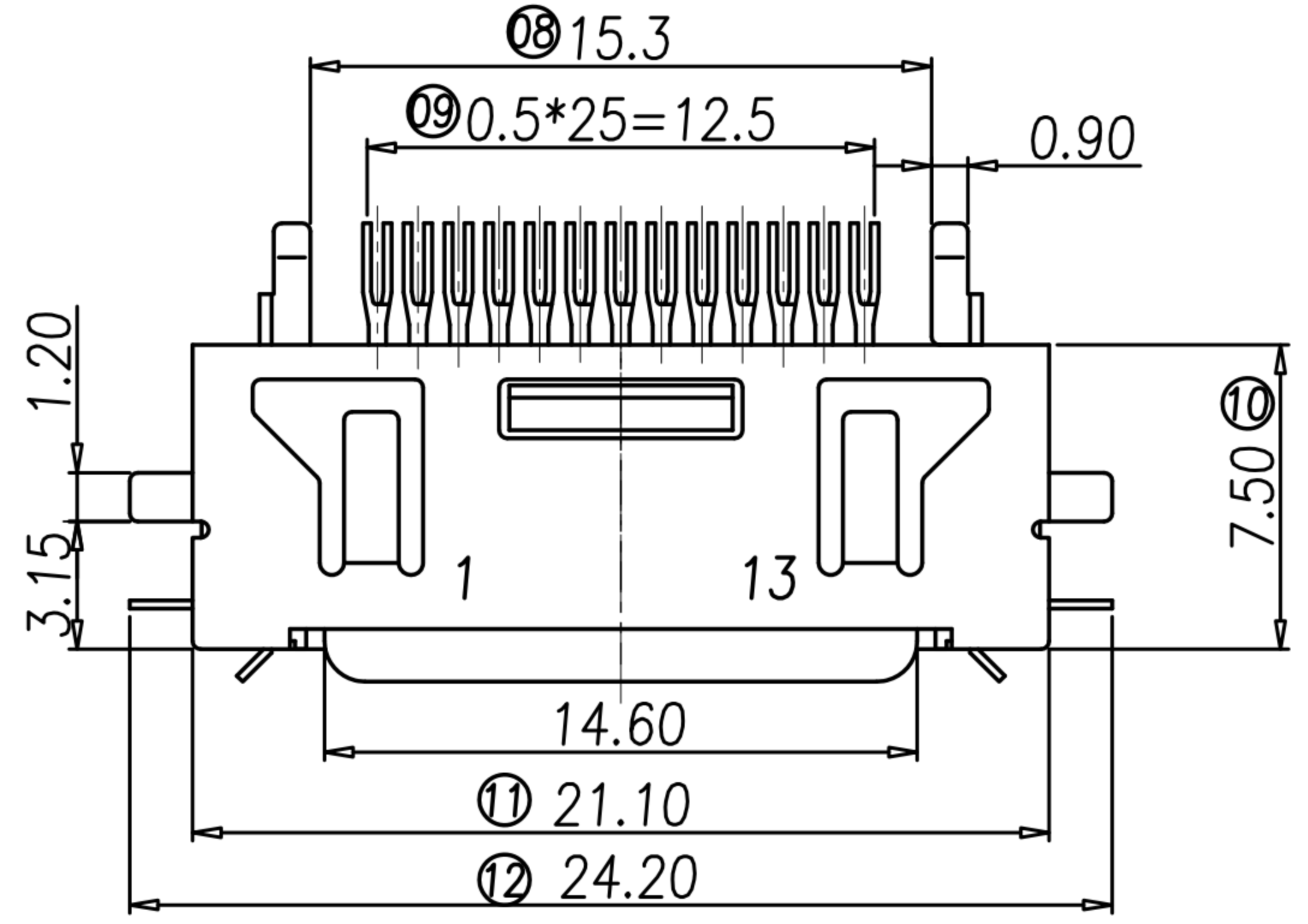

- MATERIAL :
  - 1-1. HOUSING : LCP UL94V-0 ; COLOR : BLACK
  - 1-2. CONTACT : PHOSPHOR BRONZE
  - 1-3. SHELL : COPPER ALLOY
  - 1-4. GROUND : PHOSPHOR BRONZE
- FINISH :
  - 2-1. CONTACT :
    - CONTACT AREA : SEE TABLE A
    - SOLDER AREA : SEE TABLE A
    - UNDER PLATE : NICKEL
  - 2-2. SHELL : SEE TABLE A
  - 2-3. GROUND : BRIGHT TIN OVER ALL

1	PC-26F4-02	SHELL:BRIGHT TIN OVER ALL. CONTACT: 5u" Min. GOLD PLATED. SOLDER AREA : BRIGH TIN.
2	PC-26F4-04	SHELL:MATTE TIN OVER ALL. CONTACT: 30u" Min. GOLD PLATED. SOLDER AREA : BRIGH TIN.
3	PC-26F4-05	SHELL : MATTE TIN OVER ALL. CONTACT : 30u" Min. GOLD PLATED. SOLDER AREA : GOLD FLISH
	P/N	DESCRIPTION

DRAWN	Mark Kao	APP'D	Ku Chou	UNIT	mm	TOLERANCE			广东科斯达电子科技有限公司 GUANG DONG KE SI DA ELECTRONIC TECHNOLOGY CO., LTD.	TITLE	PCMCIA 26PIN A TYPE (F)			SHEET	1/2
CHK'D	Emily Suen			SCALE	1:1	.x ±0.20 .xx ±0.10 .xxx ±0.05 .xxxx ±0.03 ANGULA ±1°				PART NO.	TABLE A	DWG NO.	QC0615	VERSION	G