

CUSTOMER DRAWING

REV.	DESCRIPTION	APPROVED BY	DATE	ECN NO.
A	RELEASE & CHANGE P/N	Emily Suen	07/12/2011'	
B				
C				

TABLE A

P/N	NUMBER OF PINS	A	B	C	D	E
DB-09F2-04	9	19.55	14.35	5.08	3.81	8.20
DB-15F2-02	15	23.36	18.20	8.89	7.62	12.00
DB-25F2-02	25	29.70	24.55	15.24	13.97	18.35

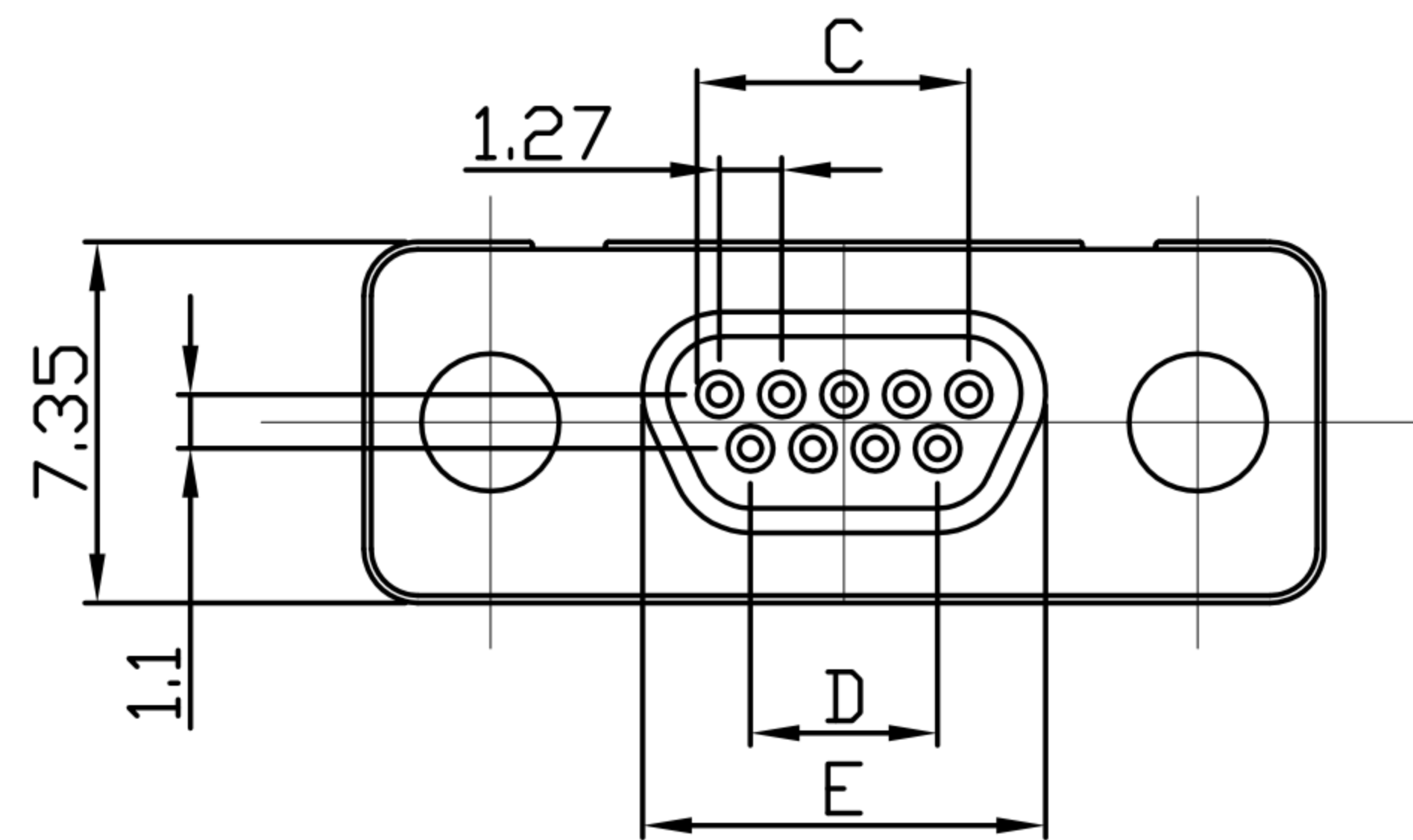
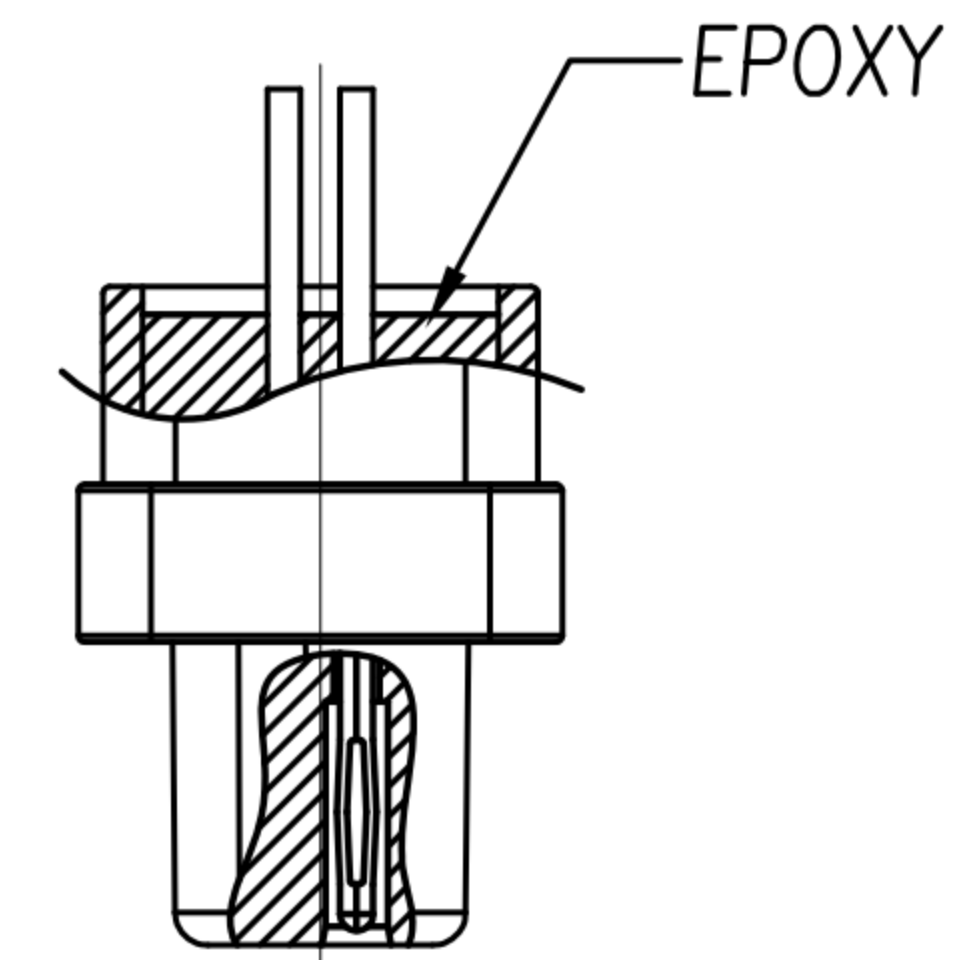
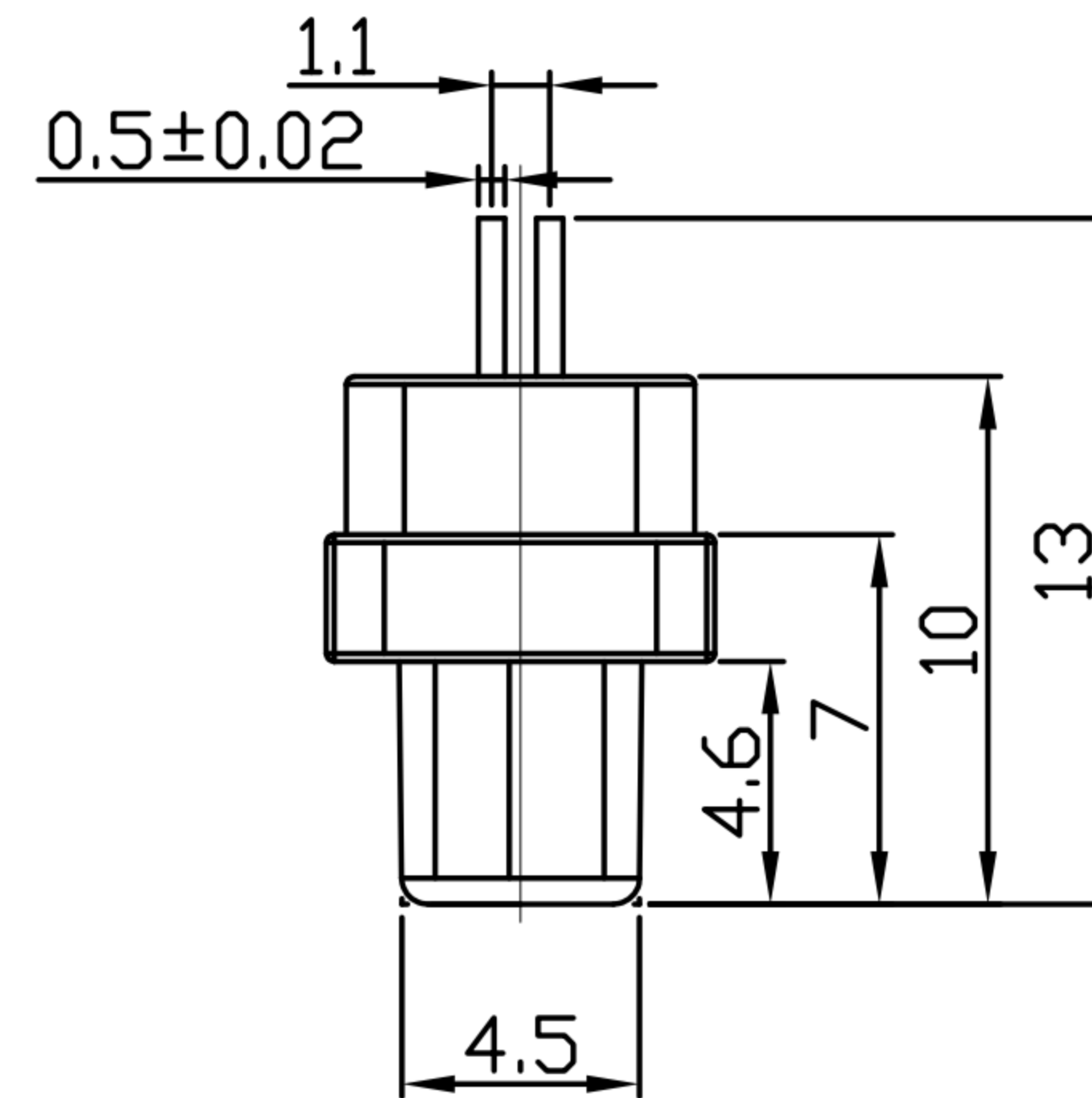
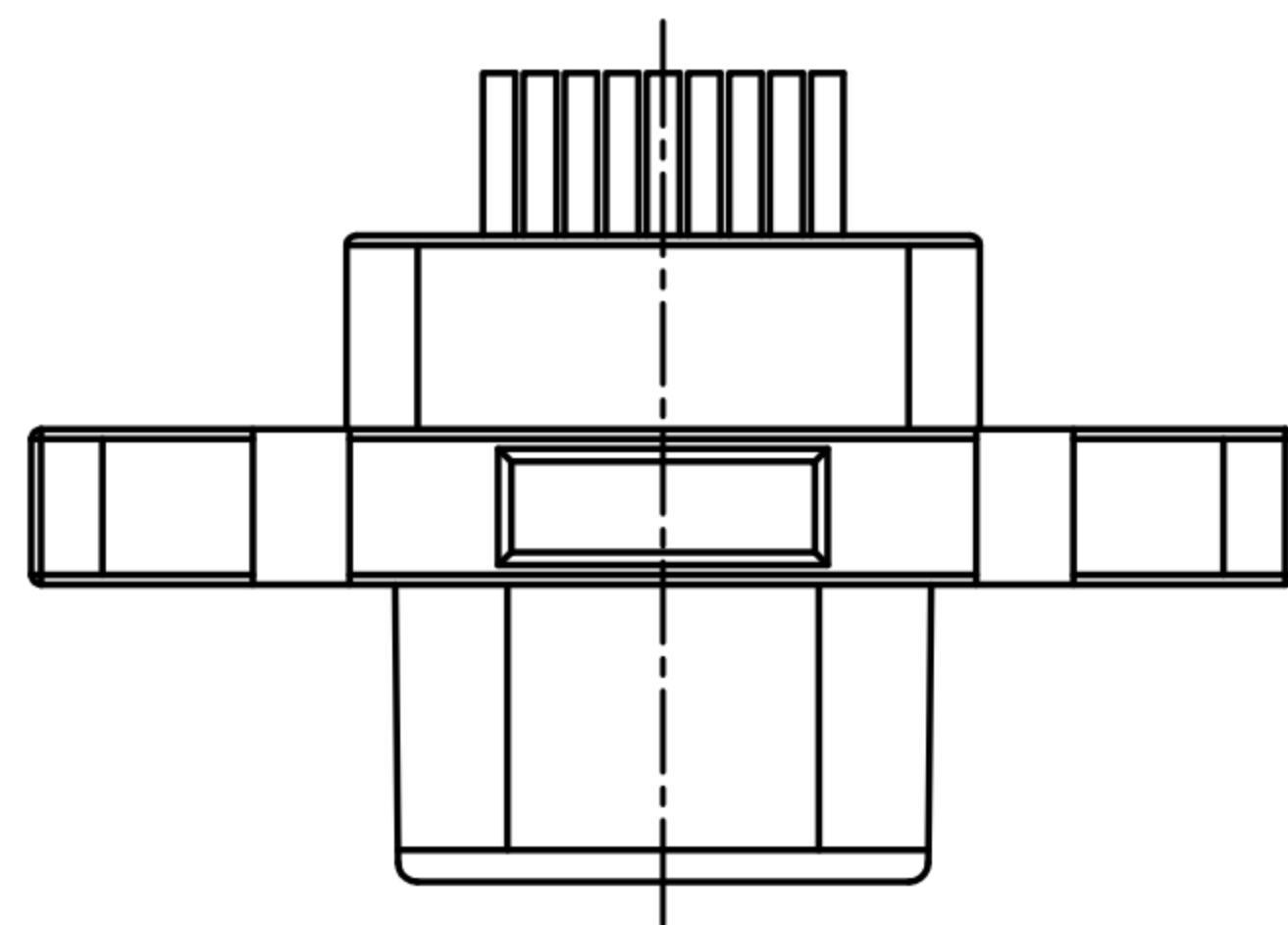
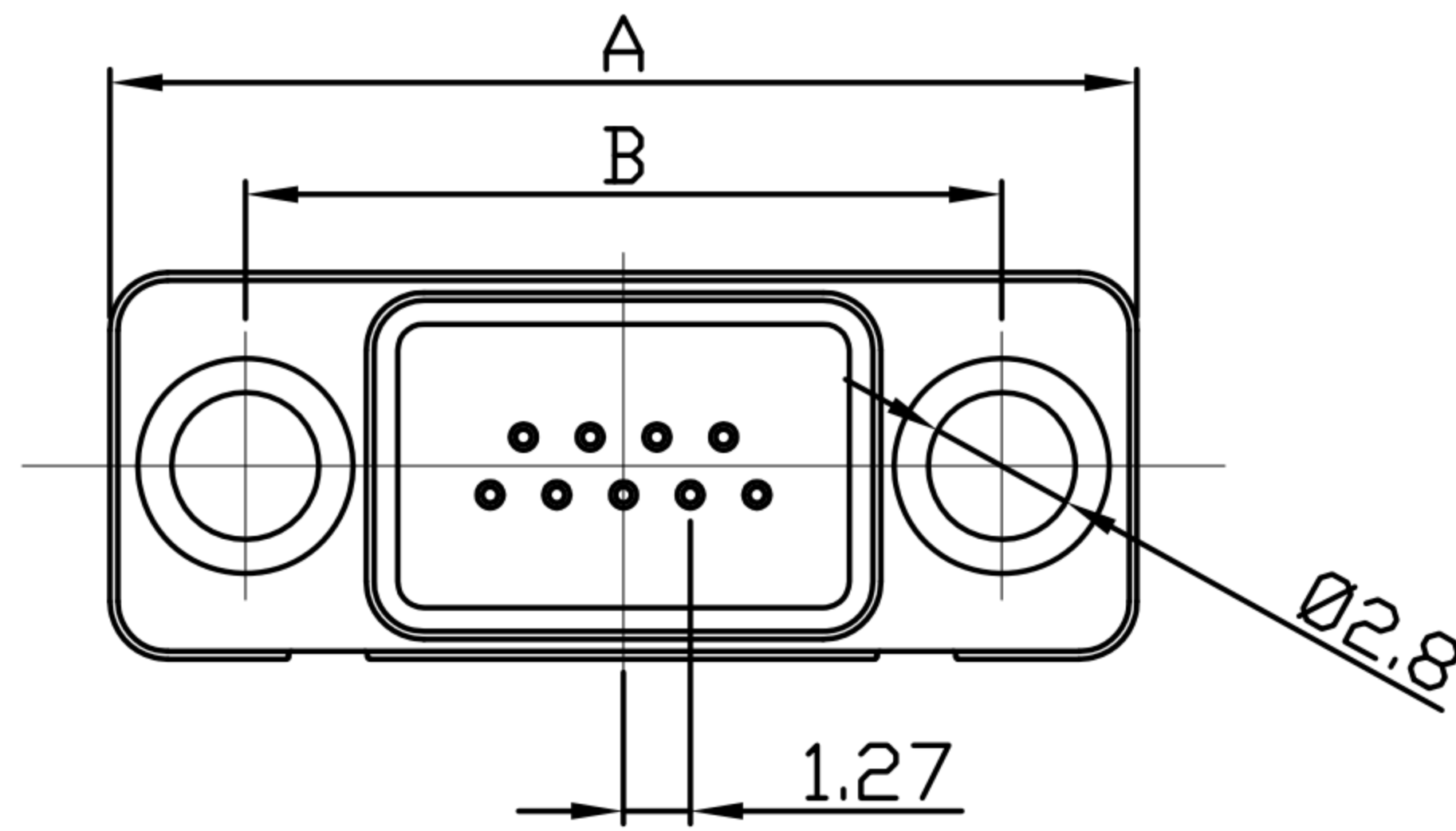

- MATERIAL :
  - 1-1. HOUSING : PBT UL94V-0 ; COLOR : BLACK
  - 1-2. CONTACT : PHOSPHOR BRONZE
  - 1-3. SHELL : Zn Alloy
- FINISH :
  - 2-1. CONTACT : 15u" GOLD OVER 60u" MIN NICKEL ON MATING AREA  
60u" MIN BRIGHT TIN OVER 60u" MIN NICKEL ON SOLDER AREA
  - 2-2. SHELL : NICKEL PLATED 60u" ~ 100u" ON OVER ALL
- ELECTRICAL SPECIFICATION :
  - 3-1. RATED CURRENT : 1A at 25c/77F, 0.7A at 70c/158F
  - 3-2. VOLTAGE : 350Vac
  - 3-3. WITHSTANDING VOLTAGE: 630V AC
  - 3-4. CONTACT RESISTANCE: 15 m (MAX) INITIAL  
CONTACT RESISTANCE: 30 m (MAX) FINAL
  - 3-5. INSULATION RESISTANCE: 1000 M ohms (MIN)
- Environmental :
  - 4-1. Operation Temperature : -40C~+125C

DRAWN	Yeh Chou	APP'D	Emily Suen	UNIT	mm	TOLERANCE		广东科斯达电子科技有限公司 GUANG DONG KE SI DA ELECTRONIC TECHNOLOGY CO., LTD.	TITLE	MICRO D-SUB FEMALE 9P-25P			SHEET	VERSION A
CHK'D	Emily Suen			SCALE	1:1	.x ±0.20 .xx ±0.15 .xxx ±0.10 .xxxx ±0.05 ANGULA ±1°			PART NO.	TABLE A	DWG NO.	QC1000		