

CUSTOMER DRAWING

REV.	DESCRIPTION	APPVL. BY	DATE	ECN NO.
C	RELEASE TABLE A	Fido Weng	12/01/10"	
D	CHANGE PLASIC TUBE MATERIAL	Emily Suen	16/05/10"	ECN11030
E	變更 TABLE A, 將 PD-04M2-29 獨立出來	Fido Weng	03/12/13"	

單箭頭

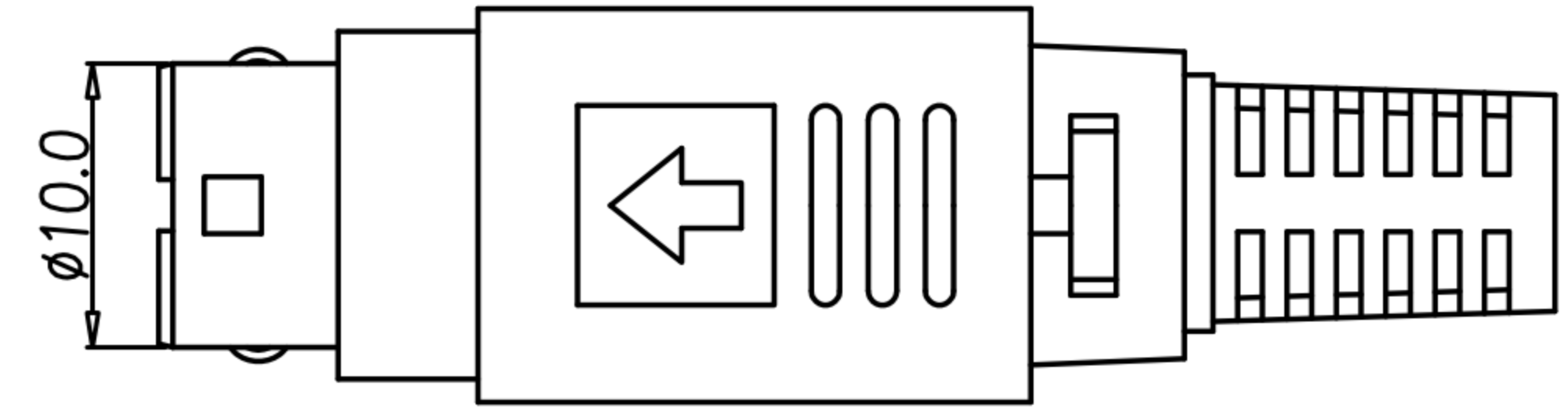

雙箭頭

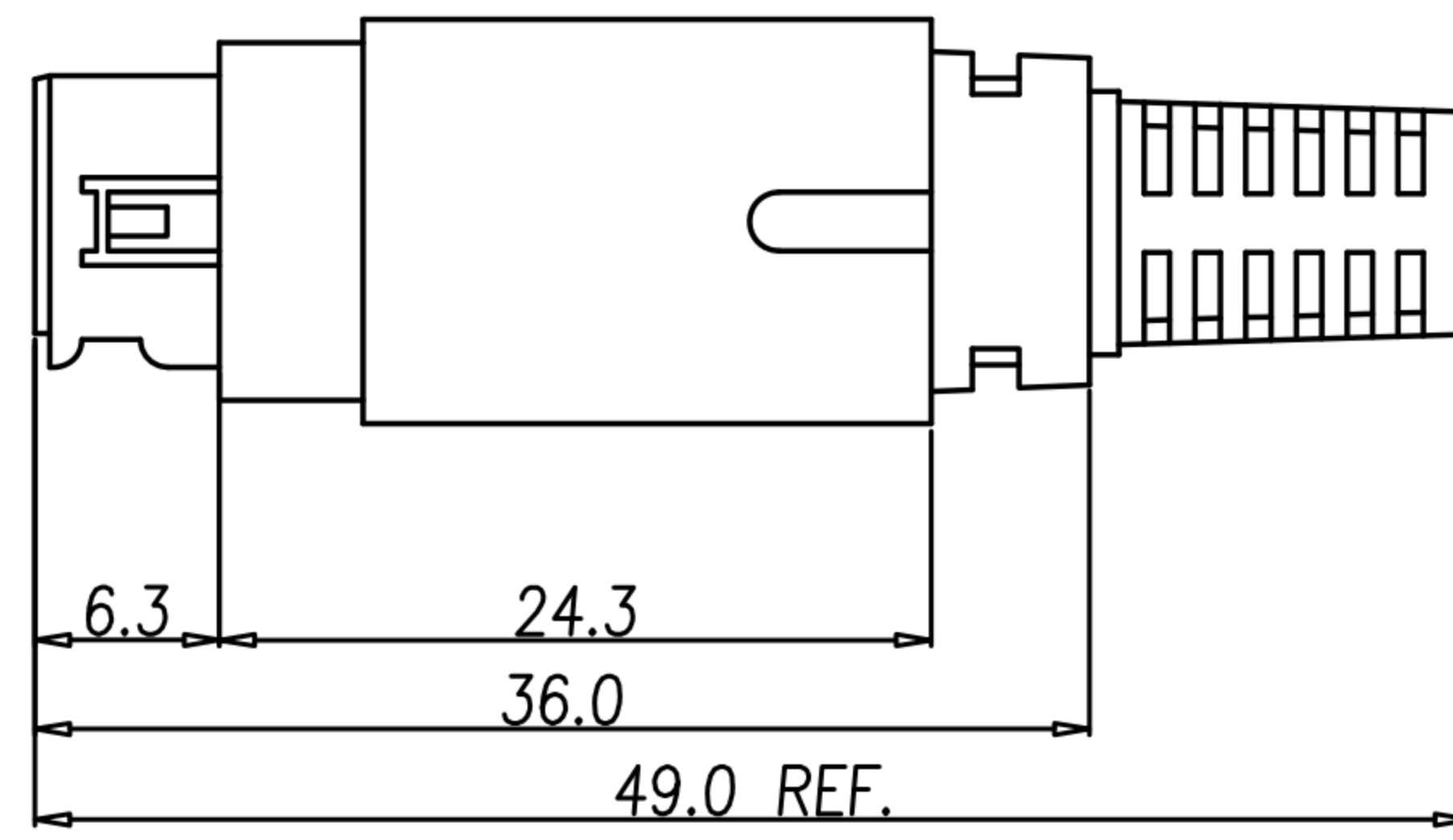
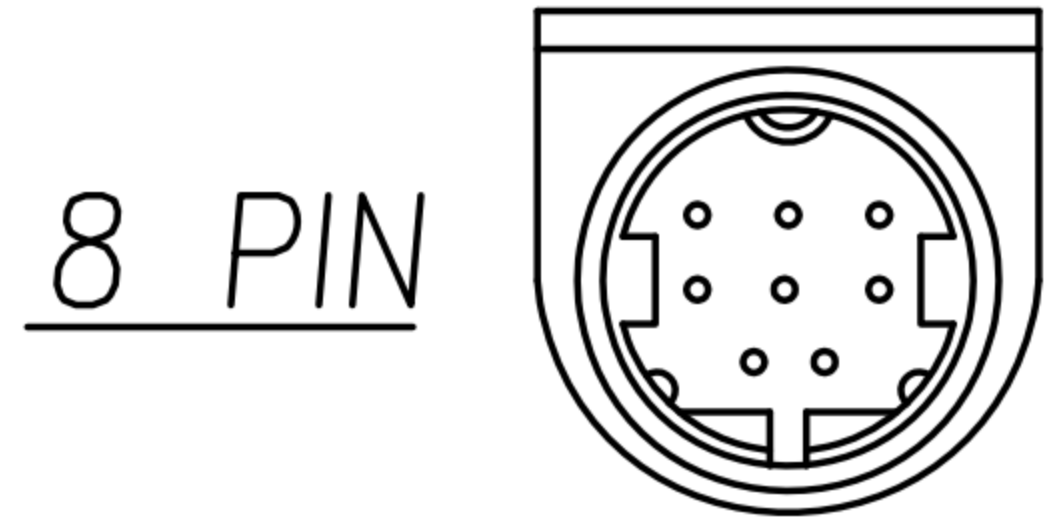
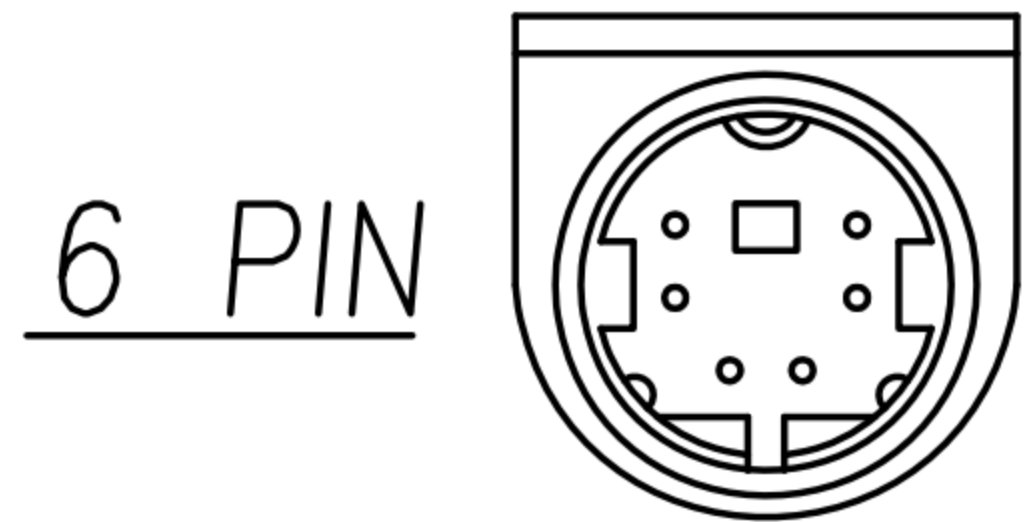
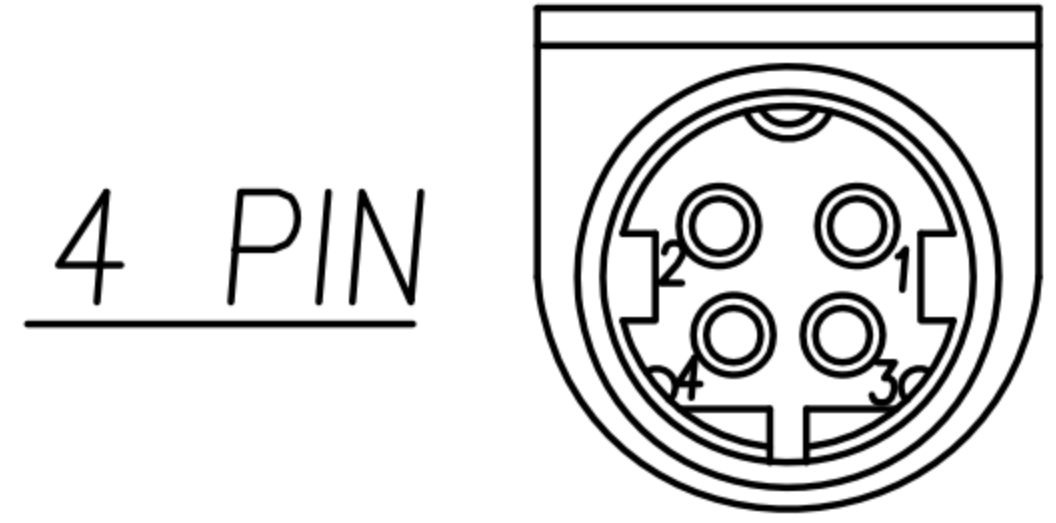
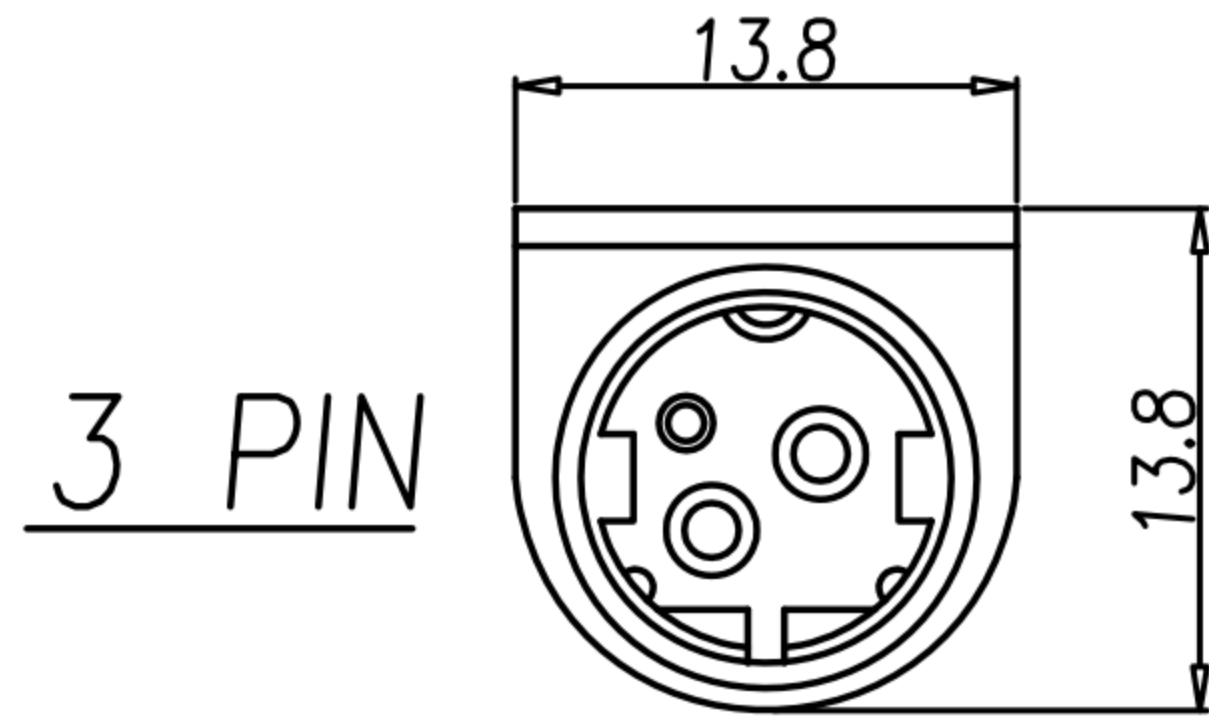
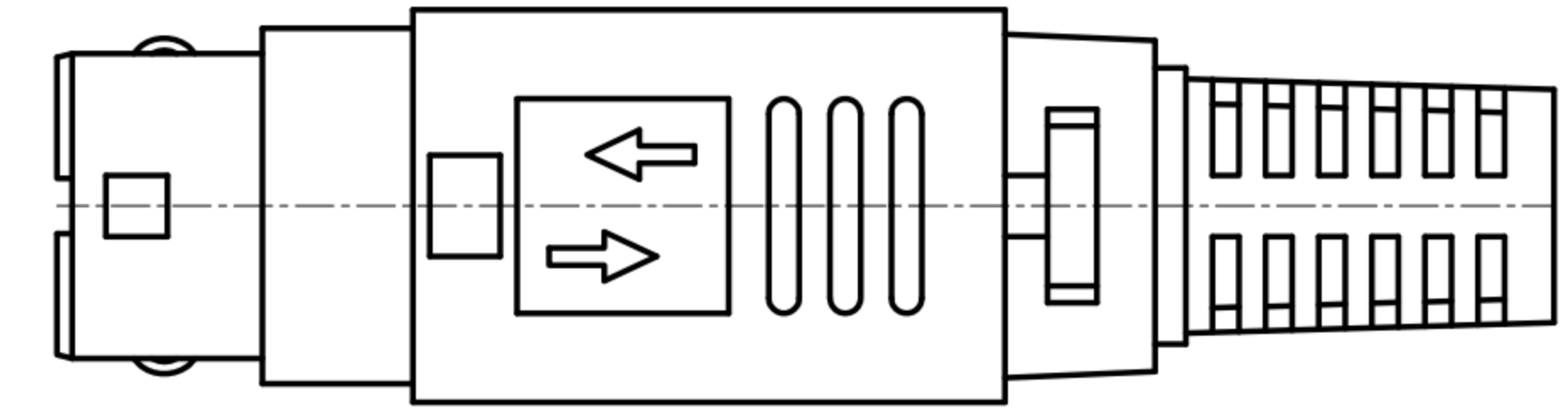

- MATERIAL :
 - 1-1. HOUSING : PBT UL94V-0 ; COLOR : BLACK.
 - 1-2. CONTACT : BRASS.
 - 1-3. PLASTIC COVER : ABS ; COLOR : SEE TABLE A
 - 1-4. PLASTIC TUBE : ABS OR PC ; COLOR : SEE TABLE A
 - 1-5. POM RING : POM ; COLOR : BLACK.
 - 1-6. SR : PVC ; COLOR : SEE TABLE A.
 - 1-7. SPRING : CARBPN STEEL OR STAINLESS STEEL
 - 1-8. METAL CAP : BRASS
 - 1-9. METAL SHELL: BRASS
- FINISH :
 - 2-1. CONTACT : 50 MICRO INCHES MIN. SILVER PLATED
 - 2-4. SPRING : NICKEL PLATED 60u" ~ 100u" OVER ALL.
 - 2-4. METAL CAP : NICKEL PLATED 60u" ~ 100u" OVER ALL.
 - 2-4. METAL SHELL : NICKEL PLATED 60u" ~ 100u" OVER ALL.
- ELECTRICAL SPECIFICATION :
 - 3-1. RATED CURRENT : 4PIN: 7.5A/DC MAX
3PIN: PIN1 & PIN2 7.5A/DC ; PIN3 1A/DC
 - 3-2. VOLTAGE : 20V/DC MAX
- ENVIRONMENTAL :
 - 4-1. OPERATION TEMPERATURE : -20 °C ~ 85°C.

DRAW	Ku Chou	APPVL	Emily Suen	UNIT	mm	TOLERANCE		广东科斯达电子科技有限公司 GUANG DONG KE SI DA ELECTRONIC TECHNOLOGY CO., LTD.	TITLE	PowerDin 變式			SHEET
CHECK	Emily Suen			SCALE	1:1	.x ±0.25 .xx ±0.15 .xxx ±0.10 .xxxx ±0.03 ANGULA ±1°			PART NO.	SEE TABLE A	DWG NO.	QC0962	VERSION

CUSTOMER DRAWING TABLE A

REV.	DESCRIPTION	APPL. BY	DATE	ECN NO.
△C	RELEASE TABLE A	Fido Weng	12/01/10"	
△D	CHANGE PLASIC TUBE MATERIAL	Emily Suen	16/05/10"	ECN11030
△E	變更 TABLE A, 將 PD-04M2-29 獨立出來	Fido Weng	03/12/13"	

3 PIN

4 PIN

PD-03M2-45	Power Din 3(M)雙前環裝配八件式	5.5	16	BLACK		端子切杯口
PD-03M2-44	Power Din 3(M)單前環裝配七件式	無SR		BLACK	二件式	中筒材質:PC/無彈簧
PD-03M2-42	Power Din 3(M)單前環裝配八件式	6.5	16.3	BLACK	二件式	無線扣
PD-03M2-41	Power Din 3(M)單前環裝配八件式	6.5	16.3	GRAY		
PD-03M2-40	Power Din 3(M)單前環裝配八件式	6.5	16.3	BLACK		SR 低鉛
PD-03M2-39	Power Din 3(M)單前環裝配八件式	6.5	16.3	BAIGI		
PD-03M2-38	Power Din 3(M)雙前環裝配七件式	無SR		BLACK		
PD-03M2-35	Power Din 3(M)雙前環裝配七件式	無SR		BLACK	二件式	中筒材質:PC/無彈簧
PD-03M2-34	Power Din 3(M)單前環裝配七件式	無SR		BLACK	二件式	中筒材質:PC
PD-03M2-33	Power Din 3(M)雙前環裝配八件式	無SR		BLACK	二件式	中筒材質:PC
PD-03M2-32	Power Din 3(M)雙前環裝配八件式	7.0	16.15	BLACK		
PD-03M2-31	Power Din 3(M)雙前環裝配八件式	6.5	16.3	BLACK		
PD-03M2-30	Power Din 3(M)單前環裝配八件式	4.0	15.9±0.3	BLACK		端子切杯口
PD-03M2-28	Power Din 3(M)單前環裝配九件式	6.5	16.3	BLACK	二件式	端子切杯口/彈簧材質:不銹鋼
PD-03M2-26	Power Din 3(M)單前環裝配八件式	5.5	16	BLACK		SR 黃色
PD-03M2-25	Power Din 3(M)雙前環裝配八件式	4.0	15.9±0.3	BLACK		
PD-03M2-24	Power Din 3(M)雙前環裝配八件式	5.0	16.4	BLACK		
PD-03M2-23	Power Din 3(M)單前環裝配九件式	5.5	16	BLACK	二件式	端子切杯口
PD-03M2-22	Power Din 3(M)單前環裝配九件式	7.0	16.15	BLACK	二件式	
PD-03M2-20	Power Din 3(M)單前環裝配八件式	7.0	16.15	BLACK		
PD-03M2-18	Power Din 3(M)單前環裝配八件式	5.5	16	BLACK		
PD-03M2-17	Power Din 3(M)雙前環裝配八件式	5.5	16	BLACK		
PD-03M2-15	Power Din 3(M)單前環裝配九件式	4.0	15.9±0.3	BLACK	二件式	
PD-03M2-13	Power Din 3(M)單前環裝配八件式	5.0	16.4	BLACK		
PD-03M2-11	Power Din 3(M)單前環裝配九件式	6.5	16.3	BAIGI	二件式	
PD-03M2-10	Power Din 3(M)單前環裝配八件式	6.5	16.3	BLACK		
PD-03M2-08	Power Din 3(M)單前環裝配九件式	5.5	16	GRAY	二件式	
PD-03M2-05	Power Din 3(M)單前環裝配八件式	5.5	16	BLACK		端子切杯口
PD-03M2-04	Power Din 3(M)雙前環裝配九件式	6.5	16.3	BLACK	二件式	
PD-03M2-03	Power Din 3(M)單前環裝配九件式	6.5	16.3	BLACK	二件式	
PD-03M2-02	Power Din 3(M)單前環裝配九件式	5.0	16.4	BLACK	二件式	
PD-03M2-01	Power Din 3(M)單前環裝配九件式	5.5	16	BLACK	二件式	
P/N	DESCRIPTION	SR OD ØD:	SR L DIM	COLOR	MATEL SHELL	NOTE

PD-04M2-45-11	Power Din 4(M)雙前環裝配八件式	6.5	16.3	BLACK		端子切杯口
PD-04M2-39	Power Din 4(M)雙前環裝配七件式	無SR		BLACK		
PD-04M2-36	Power Din 4(M)雙前環裝配八件式	4.0	15.9±0.3	BLACK		
PD-04M2-35	Power Din 4(M)裝配六件式	無SR		BLACK	二件式	中筒材質:PC/無彈簧/無外蓋
PD-04M2-34	Power Din 4(M)雙前環裝配八件式	5.0	16.4	BLACK		
PD-04M2-33	Power Din 4(M)雙前環裝配七件式	無SR		BLACK	二件式	中筒材質:PC/無彈簧
PD-04M2-32	Power Din 4(M)單前環裝配八件式	7.0	16.15	BLACK		
PD-04M2-31	Power Din 4(M)單前環裝配八件式	無SR		BLACK	二件式	中筒材質:PC/無后蓋
PD-04M2-30	Power Din 4(M)雙前環裝配八件式	無SR		BLACK	二件式	中筒材質:PC
PD-04M2-28	Power Din 4(M)單前環裝配七件式	無SR		BLACK		中筒材質:PC
PD-04M2-27	Power Din 4(M)單前環裝配八件式	6.5	16.3	BLACK		端子切杯口
PD-04M2-24	Power Din 4(M)雙前環裝配九件式	5.5	16	BLACK	二件式	
PD-04M2-18	Power Din 4(M)雙前環裝配八件式	5.5	16	BLACK		
PD-04M2-16	Power Din 4(M)單前環裝配八件式	5.5	16	BLACK		
PD-04M2-15	Power Din 4(M)單前環裝配八件式	4.0	15.9±0.3	BLACK		
PD-04M2-14	Power Din 4(M)單前環裝配八件式	5.0	16.4	BLACK		
PD-04M2-10	Power Din 4(M)單前環裝配八件式	6.5	16.3	BLACK		
PD-04M2-04	Power Din 4(M)雙前環裝配八件式	6.5	16.3	BLACK		
P/N	DESCRIPTION	SR OD ØD:	SR L DIM	COLOR	MATEL SHELL	NOTE

6 PIN

PD-06M2-03	Power Din 6(M)單前環裝配九件式	5.0	16.14	BLACK	二件式	
PD-06M2-02	Power Din 6(M)雙前環裝配九件式	6.5	16.3	BLACK	二件式	
PD-06M2-01	Power Din 6(M)單前環裝配九件式	6.5	16.3	BLACK	二件式	
P/N	DESCRIPTION	SR OD ØD:	SR L DIM	COLOR	MATEL SHELL	NOTE

8 PIN

PD-08M2-05	Power Din 8(M)單前環裝配八件式	6.5	16.3	GRAY		
PD-08M2-04	Power Din 8(M)雙前環裝配八件式	5.0	16.4	BLACK		
PD-08M2-03	Power Din 8(M)雙前環裝配八件式	6.5	16.3	BLACK		
PD-08M2-02	Power Din 8(M)單前環裝配九件式	6.5	16.3	BLACK	二件式	
PD-08M2-01	Power Din 8(M)單前環裝配八件式	6.5	16.3	BLACK		
P/N	DESCRIPTION	SR OD ØD:	SR L DIM	COLOR	MATEL SHELL	NOTE

DRAW	Ku Chou	APPVL	Emily Suen	UNIT	mm	TOLERANCE			TITLE	PowerDin 裝配式			SHEET	2/6
CHECK	Emily Suen			SCALE	1:1	.x ±0.25 .xx ±0.15 .xxx ±0.10 .xxxx ±0.03 ANGULA ±1'			PART NO.	SEE TABLE A	DWG NO.	QC0962	VERSION	E

CUSTOMER DRAWING

REV.	DESCRIPTION	APPVL. BY	DATE	ECN NO.
△C	RELEASE TABLE A	Fido Weng	12/01/10"	
△D	CHANGE PLASIC TUBE MATERIAL	Emily Suen	16/05/10"	ECN11030
△E	變更 TABLE A, # PD-04M2-29 獨立版本	Fido Weng	03/12/13"	

TYPE 1

TYPE 2:切杯口

3 PIN

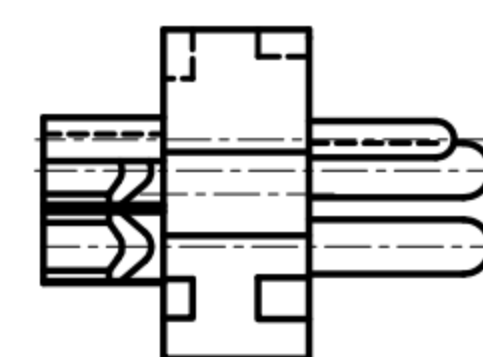
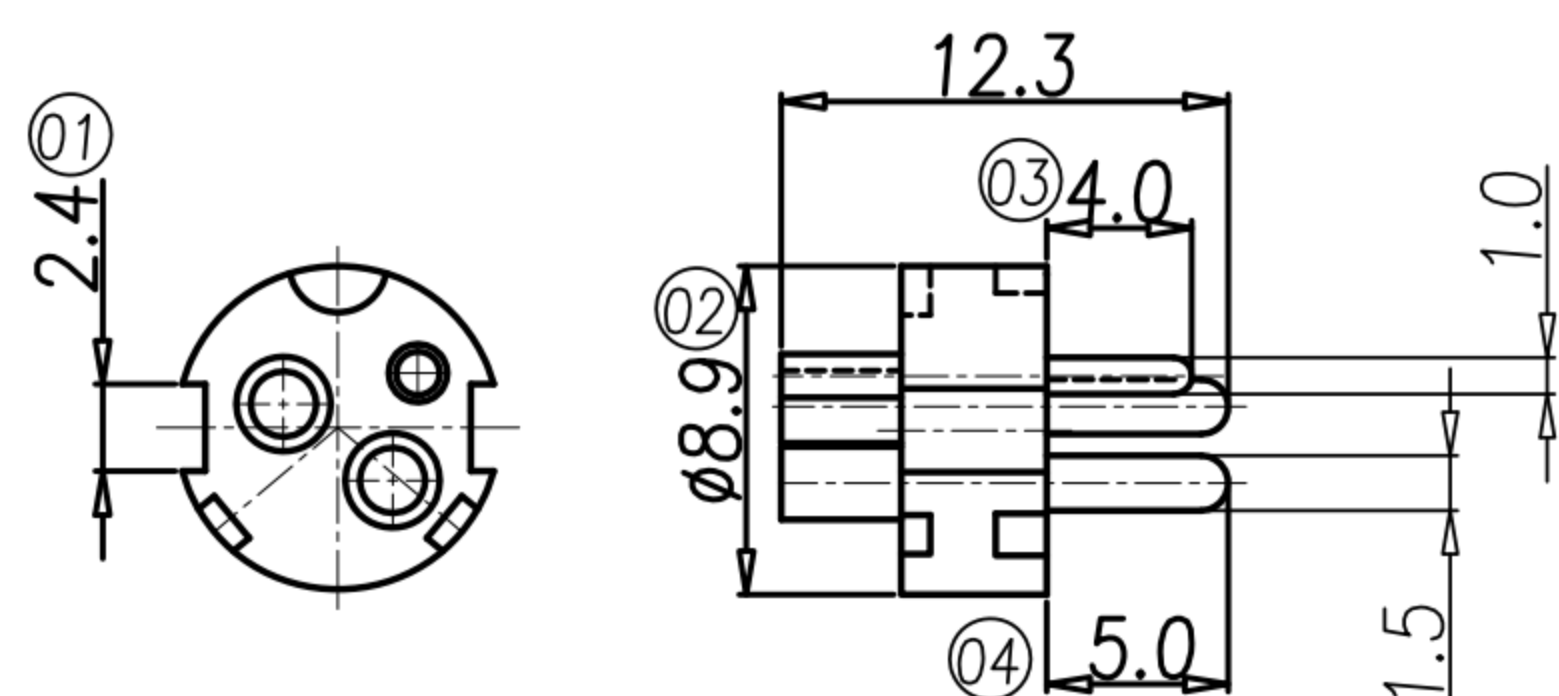

4 PIN

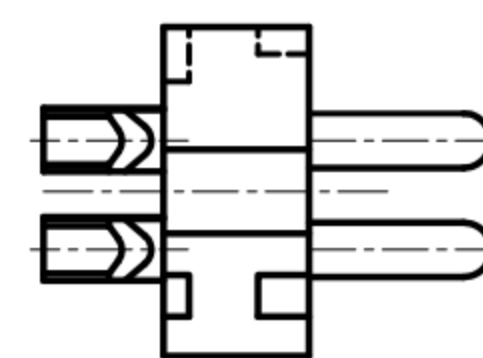
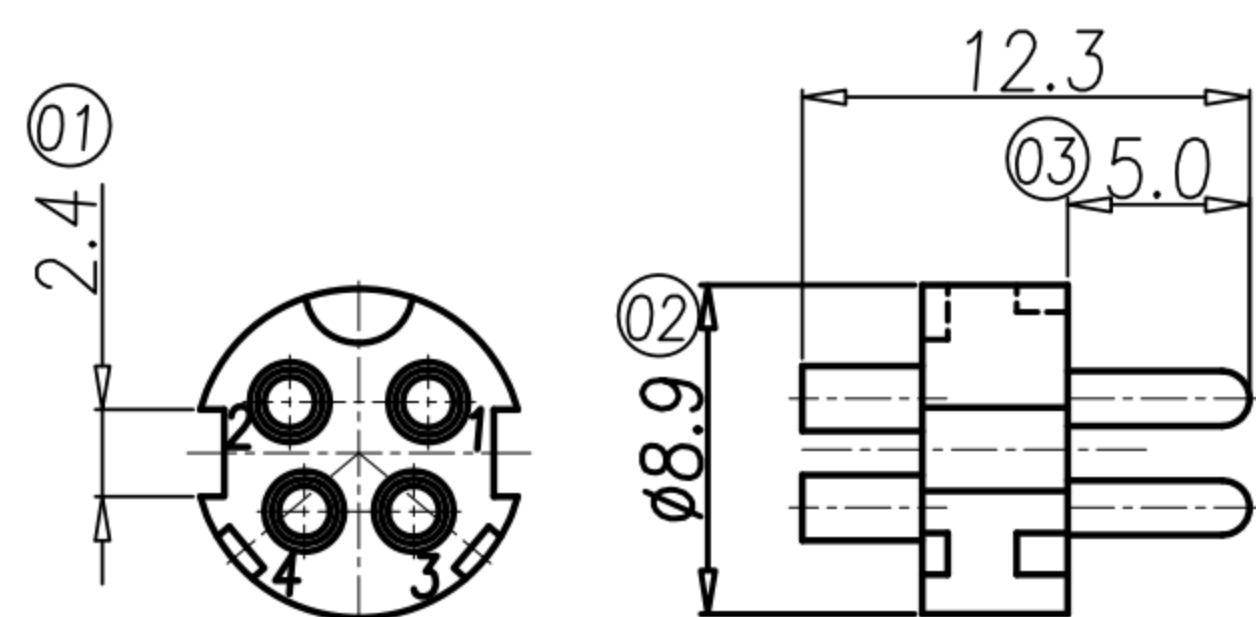

6 PIN

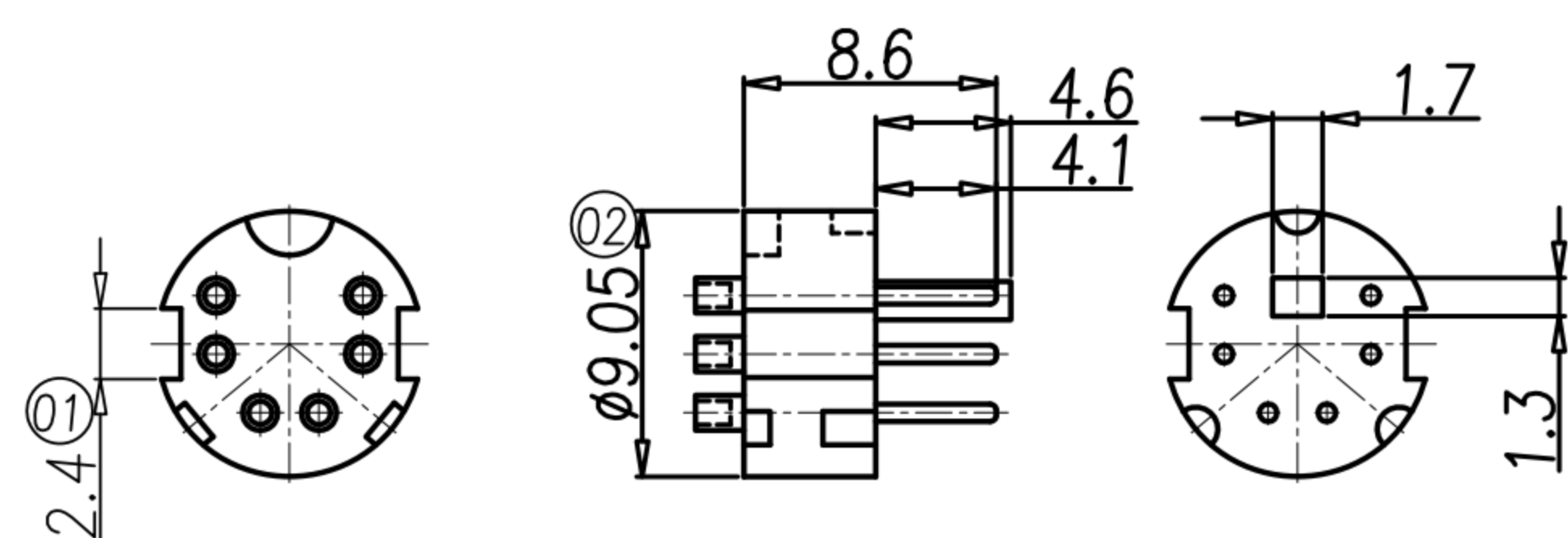

HOUSING & CONTACT ASSEMBLY.

8 PIN

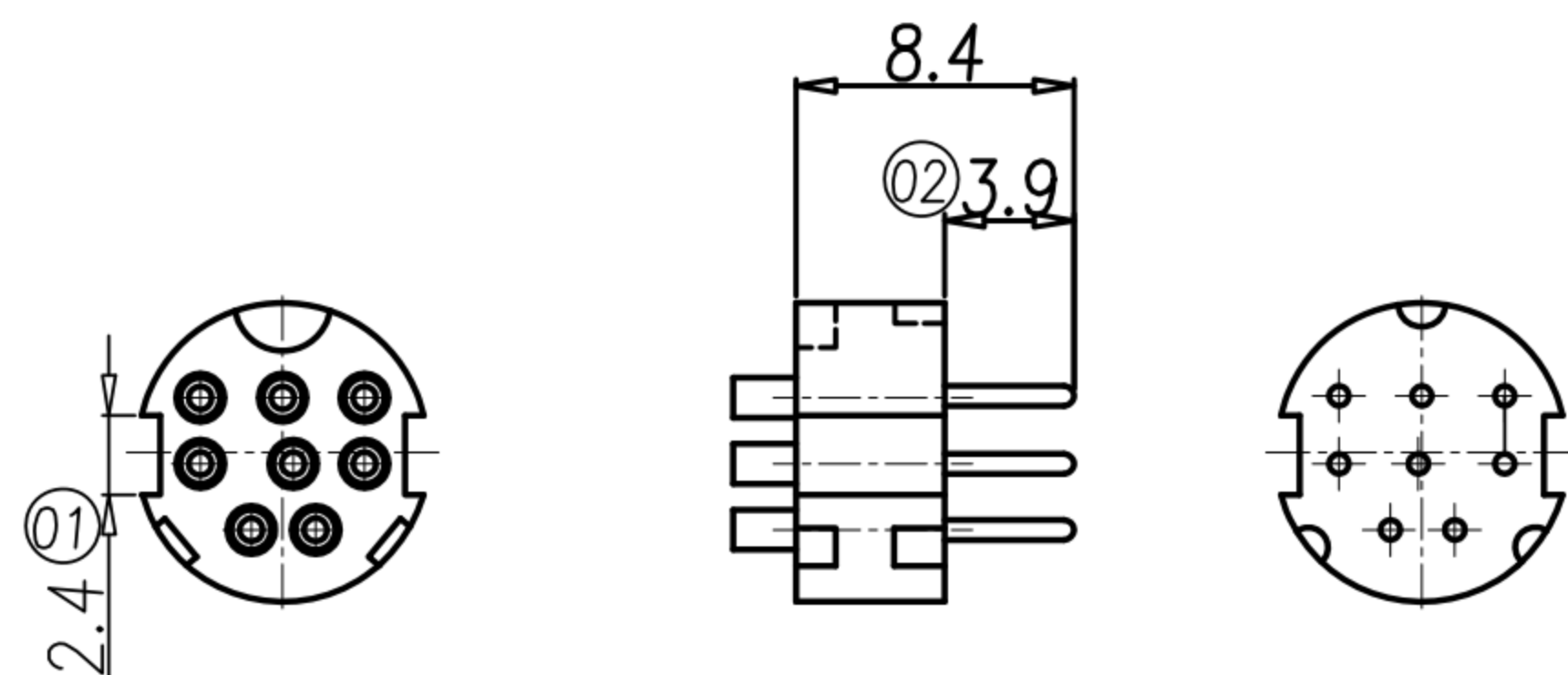

DRAW	Ku Chou	APPVL	Emily Suen	UNIT	mm	TOLERANCE .x ±0.20 .xx ±0.10 .xxx ±0.05 .xxxx ±0.03 ANGULA ±1°		广东科斯达电子科技有限公司 GUANG DONG KE SI DA ELECTRONIC TECHNOLOGY CO., LTD.	TITLE	PowerDin 款式			SHEET	3/6
CHECK	Emily Suen			SCALE	1:1				PART NO.	SEE TABLE A	DWG NO.	QC0962	VERSION	E

CUSTOMER DRAWING

REV.	DESCRIPTION	APPVL. BY	DATE	ECN NO.
△C	RELEASE TABLE A	Fido Weng	12/01/10"	
△D	CHANGE PLASIC TUBE MATERIAL	Emily Suen	16/05/10"	ECN11030
△E	變更 TABLE A, 將 PD-04M2-29 換成此表	Fido Weng	03/12/13"	

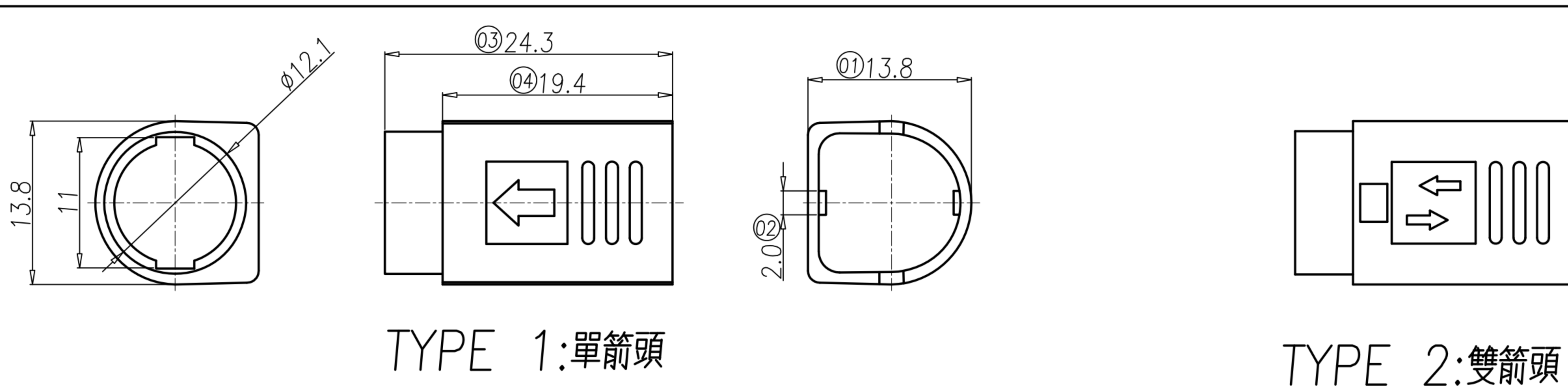

PLASTIC COVER

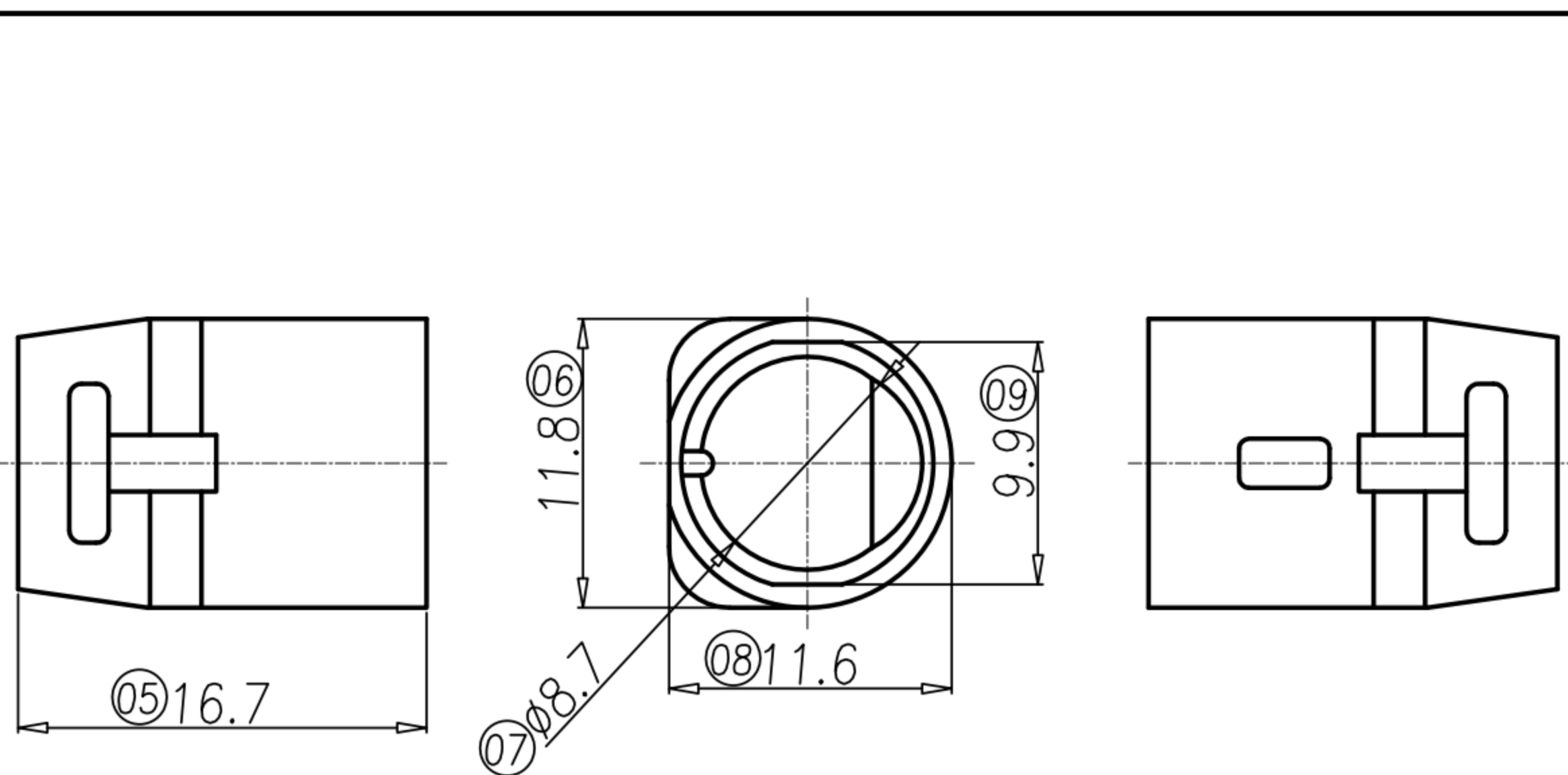

PLASTIC TUBE

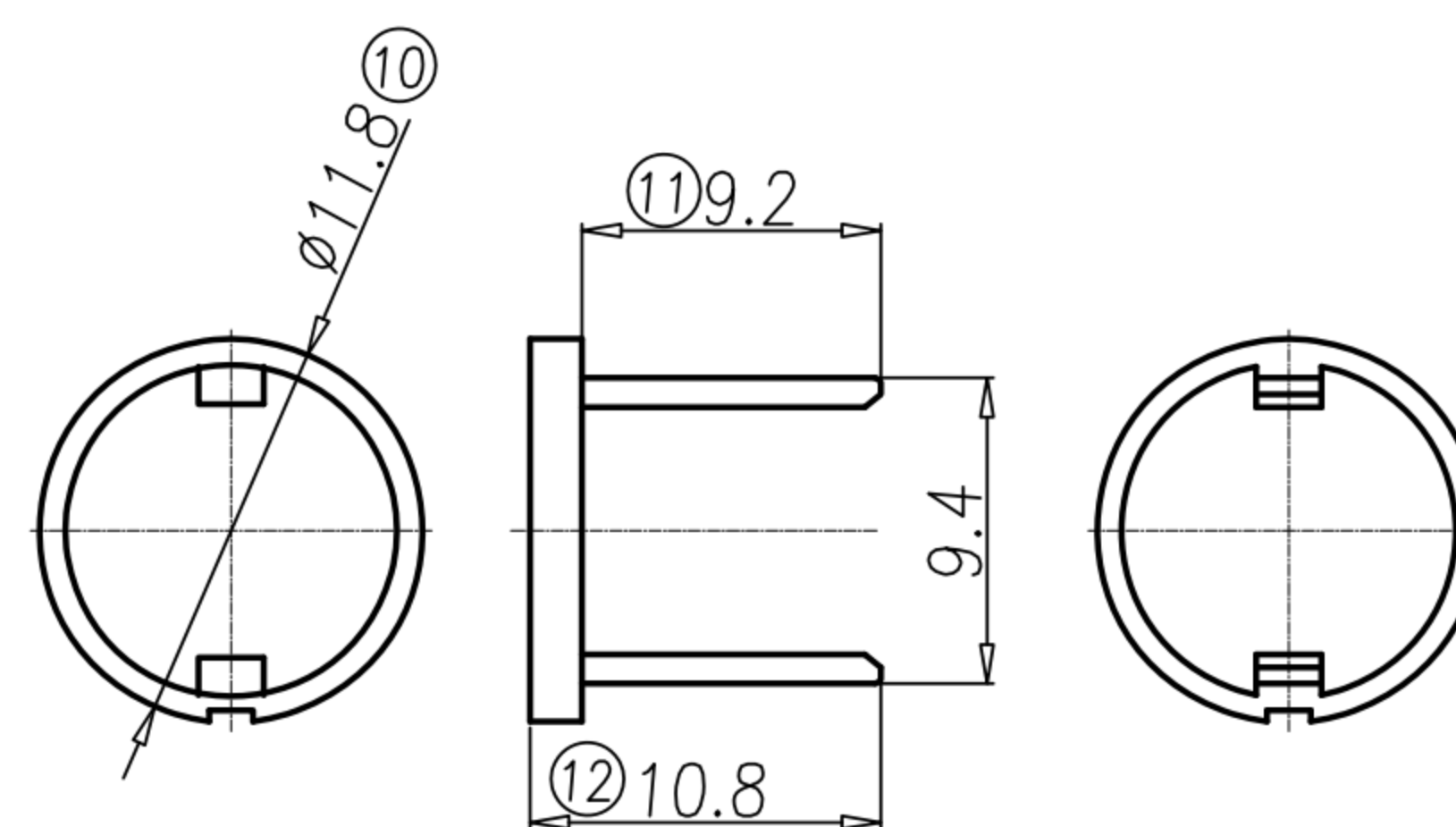

POM RING

DRAW	Ku Chou	APPVL	Emily Suen	UNIT	mm	TOLERANCE .x ±0.20 .xx ±0.10 .xxx ±0.05 .xxxx ±0.03 ANGULA ±1°			广东科斯达电子科技有限公司 GUANG DONG KE SI DA ELECTRONIC TECHNOLOGY CO., LTD.	TITLE	PowerDin 款式			SHEET	4/6
CHECK	Emily Suen			SCALE	1:1					PART NO.	SEE TABLE A	DWG NO.	QC0962	VERSION	E

CUSTOMER DRAWING

REV.	DESCRIPTION	APPVL. BY	DATE	ECN NO.
△C	RELEASE TABLE A	Fido Weng	12/01/10"	
△D	CHANGE PLASIC TUBE MATERIAL	Emily Suen	16/05/10"	ECN11030
△E	變更 TABLE A, # PD-04M2-29 獨立出來	Fido Weng	03/12/13"	

SR

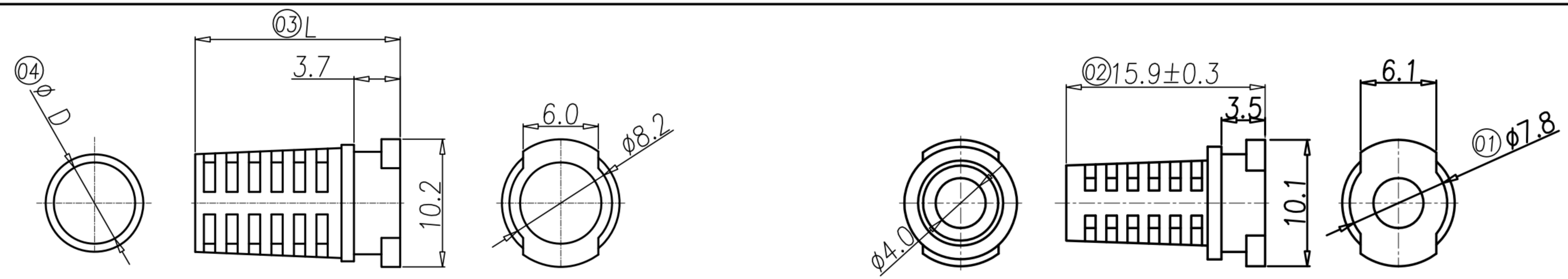

TYPE 1:
OD :SEE TABLE A

TYPE 2:OD:φ4.0

SPRING

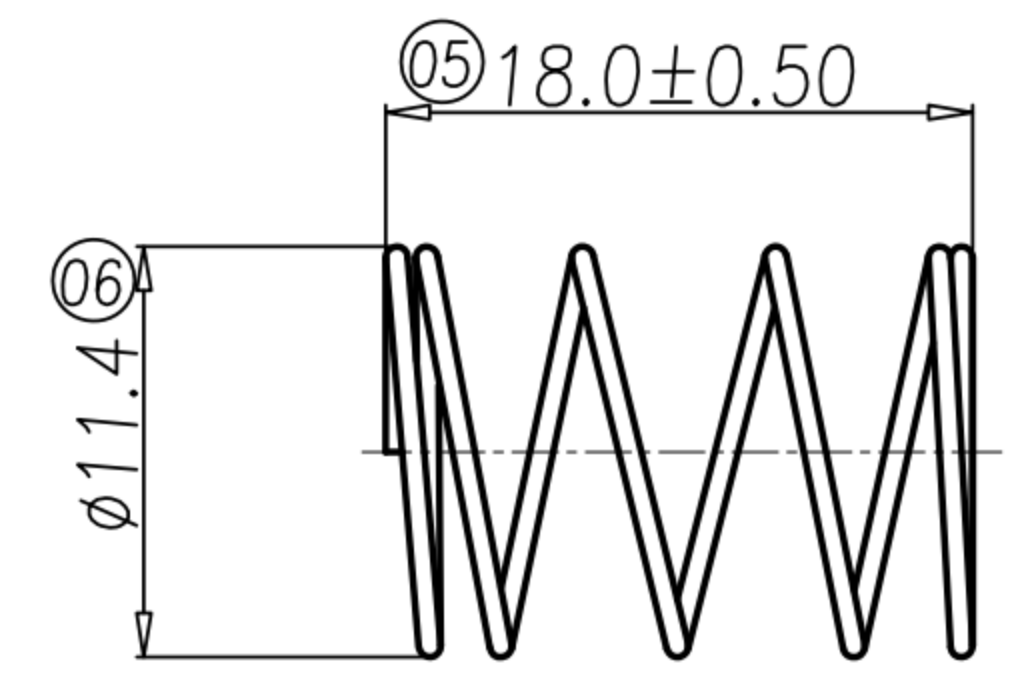

MATEL CAP

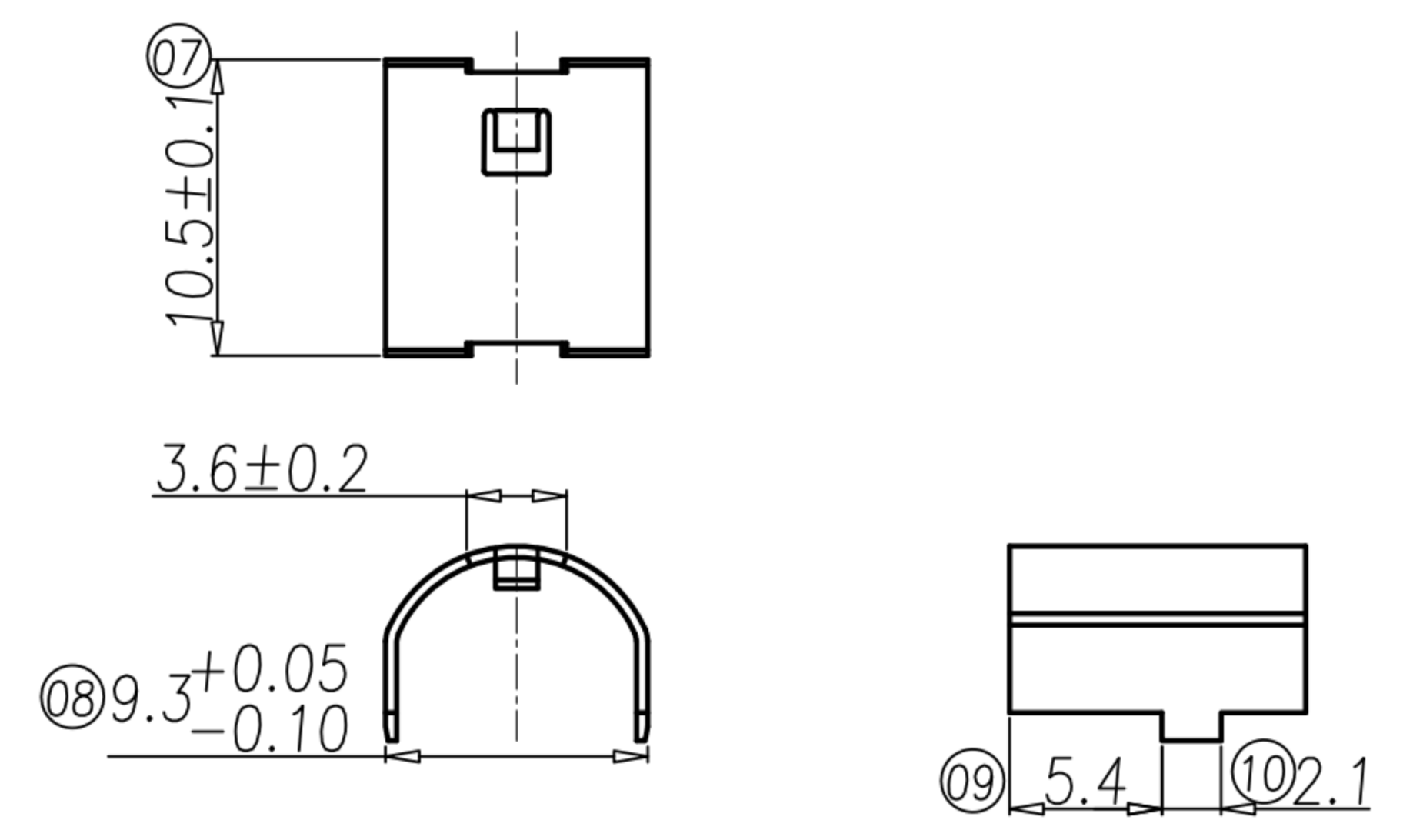

DRAW	Ku Chou	APPVL	Emily Suen	UNIT	mm	TOLERANCE .x ±0.20 .xx ±0.10 .xxx ±0.05 .xxxx ±0.03 ANGULA ±1°			TITLE	PowerDin 變壓式			SHEET	5/6
CHECK	Emily Suen			SCALE	1:1				PART NO.	SEE TABLE A	DWG NO.	QC0962	VERSION	E

CUSTOMER DRAWING

REV.	DESCRIPTION	APPVL. BY	DATE	ECN NO.
△C	RELEASE TABLE A	Fido Weng	12/01/10"	
△D	CHANGE PLASIC TUBE MATERIAL	Emily Suen	16/05/10"	ECN11030
△E	變更 TABLE A, 將 PD-04M2-29 獨立出來	Fido Weng	03/12/13"	

TYPE 1:一件式(銅管+線扣)

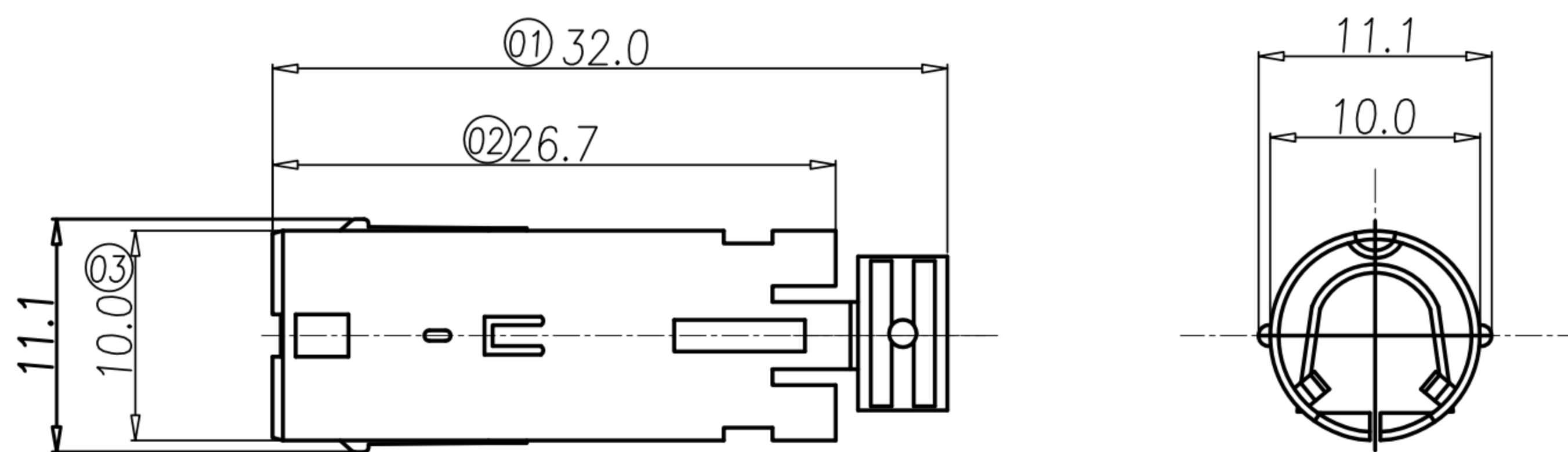

銅管

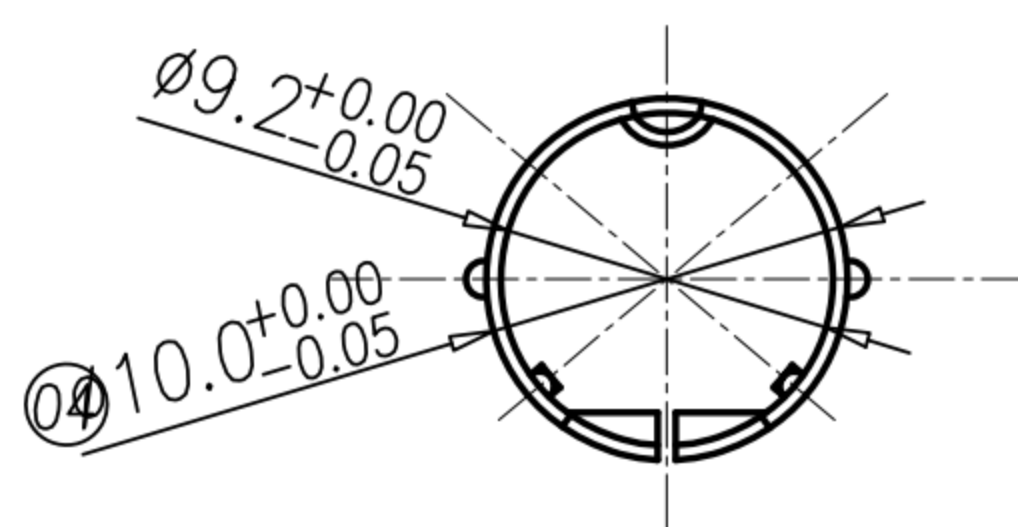

TYPE 2:二件式

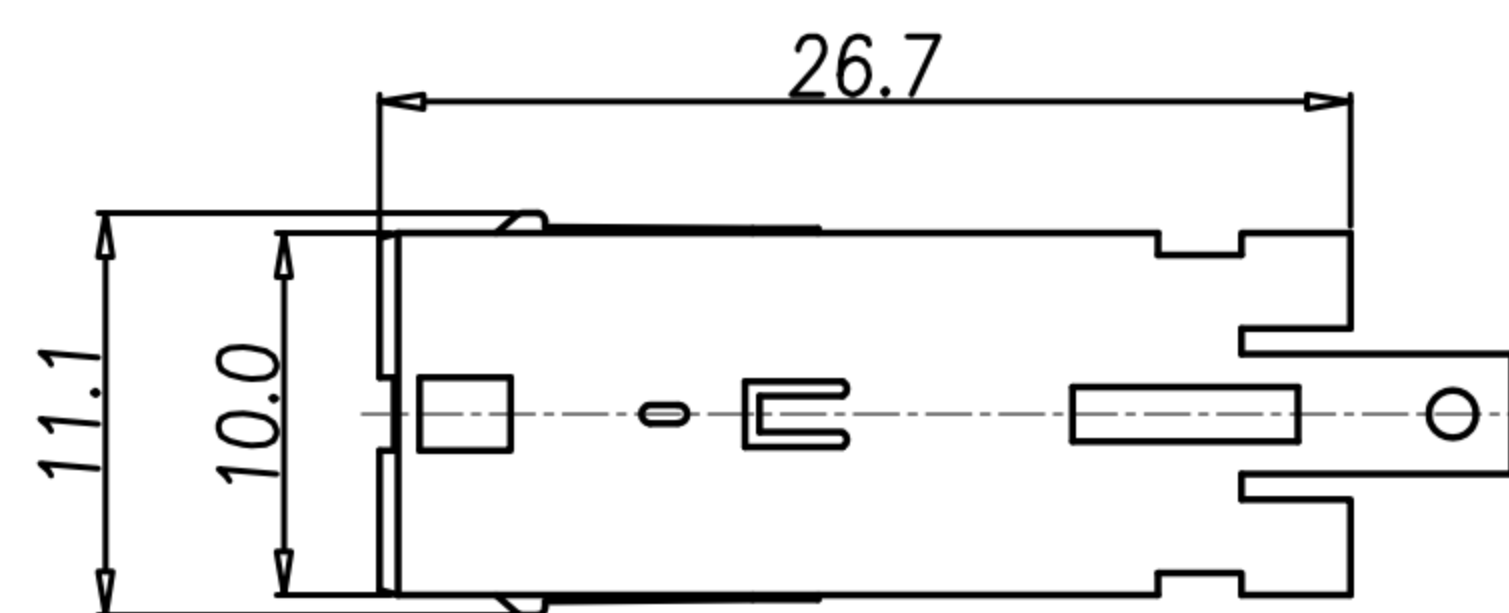

線扣

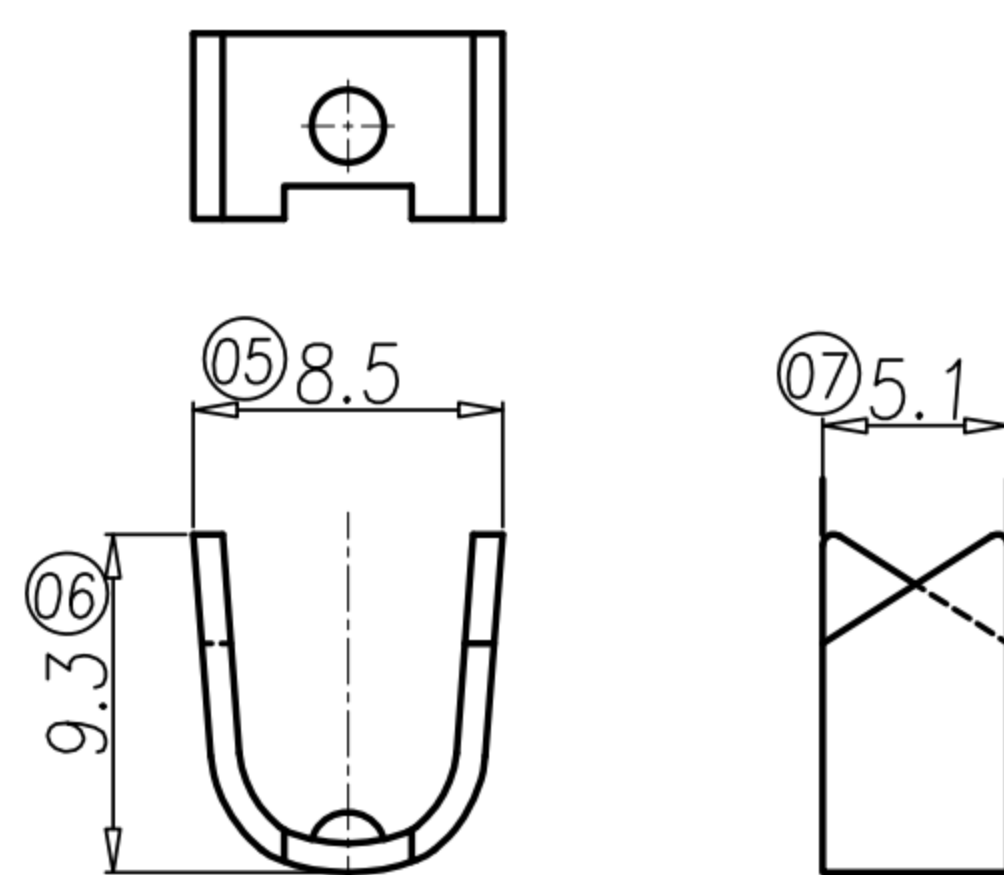

MATEL SHELL

DRAW	Ku Chou	APPVL	Emily Suen	UNIT	mm	TOLERANCE .x ±0.20 .xx ±0.10 .xxx ±0.05 .xxxx ±0.03 ANGULA ±1°		广东科斯达电子科技有限公司 GUANG DONG KE SI DA ELECTRONIC TECHNOLOGY CO., LTD.	TITLE	PowerDin 變式			SHEET	6/6
CHECK	Emily Suen			SCALE	1:1				PART NO.	SEE TABLE A	DWG NO.	QC0962	VERSION	E