

CUSTOMER DRAWING

REV.	DESCRIPTION	APPROVED BY	DATE	ECN NO.
△A	RELEASE	Emily Suen	23/03/11*	
△B				
△C				

- 步驟一:
1. 將成品放入PE袋
 2. 每個PE袋裝1000PCS後以熱封機熱封

- 步驟二:
1. 一個紙箱可以裝10個PE袋
 2. 每箱10000pcs.
 3. 將PE袋放紙箱中,後封箱.

- 步驟三:
1. 用膠帶將紙箱封實.
 2. 將標籤貼於紙箱上.

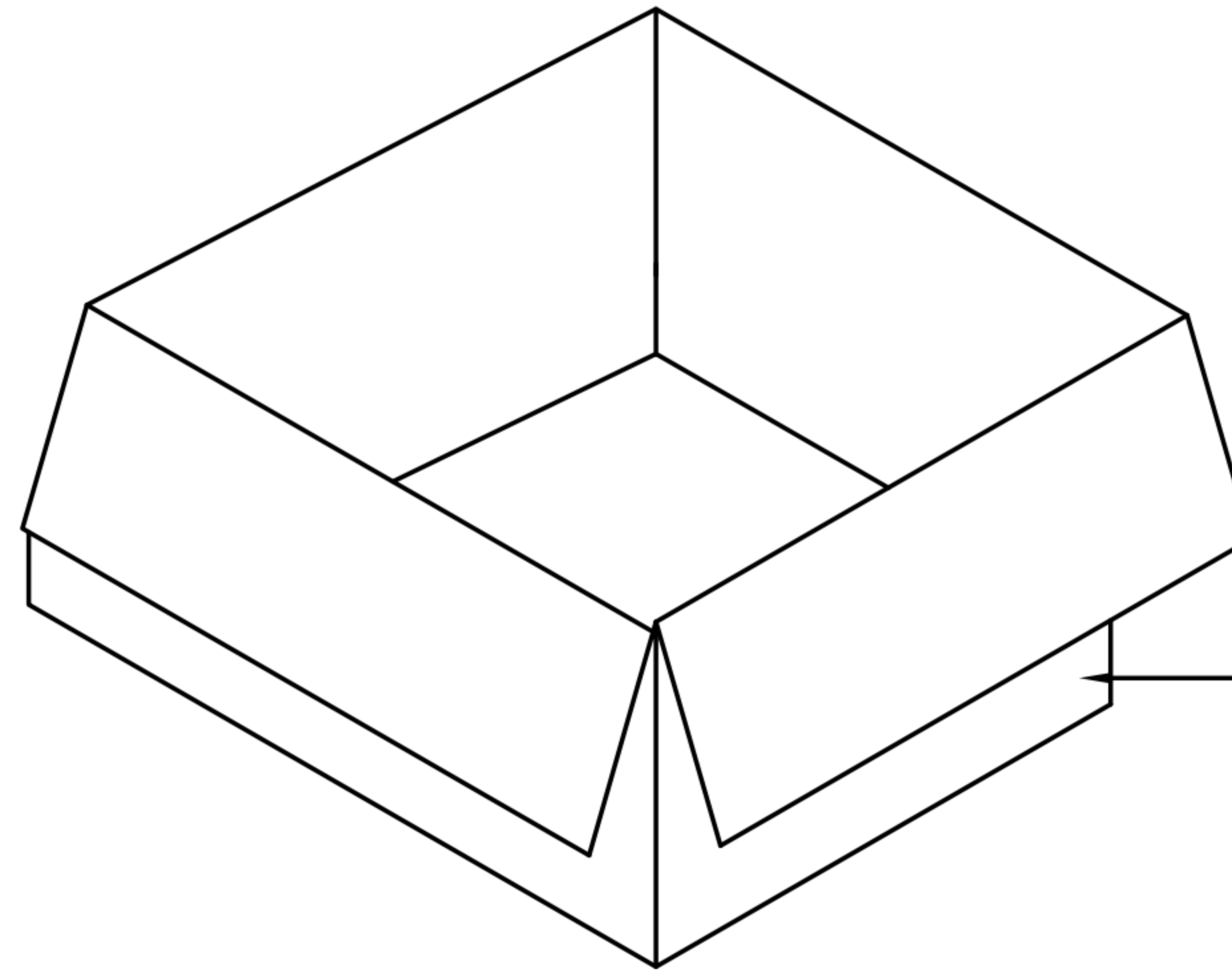
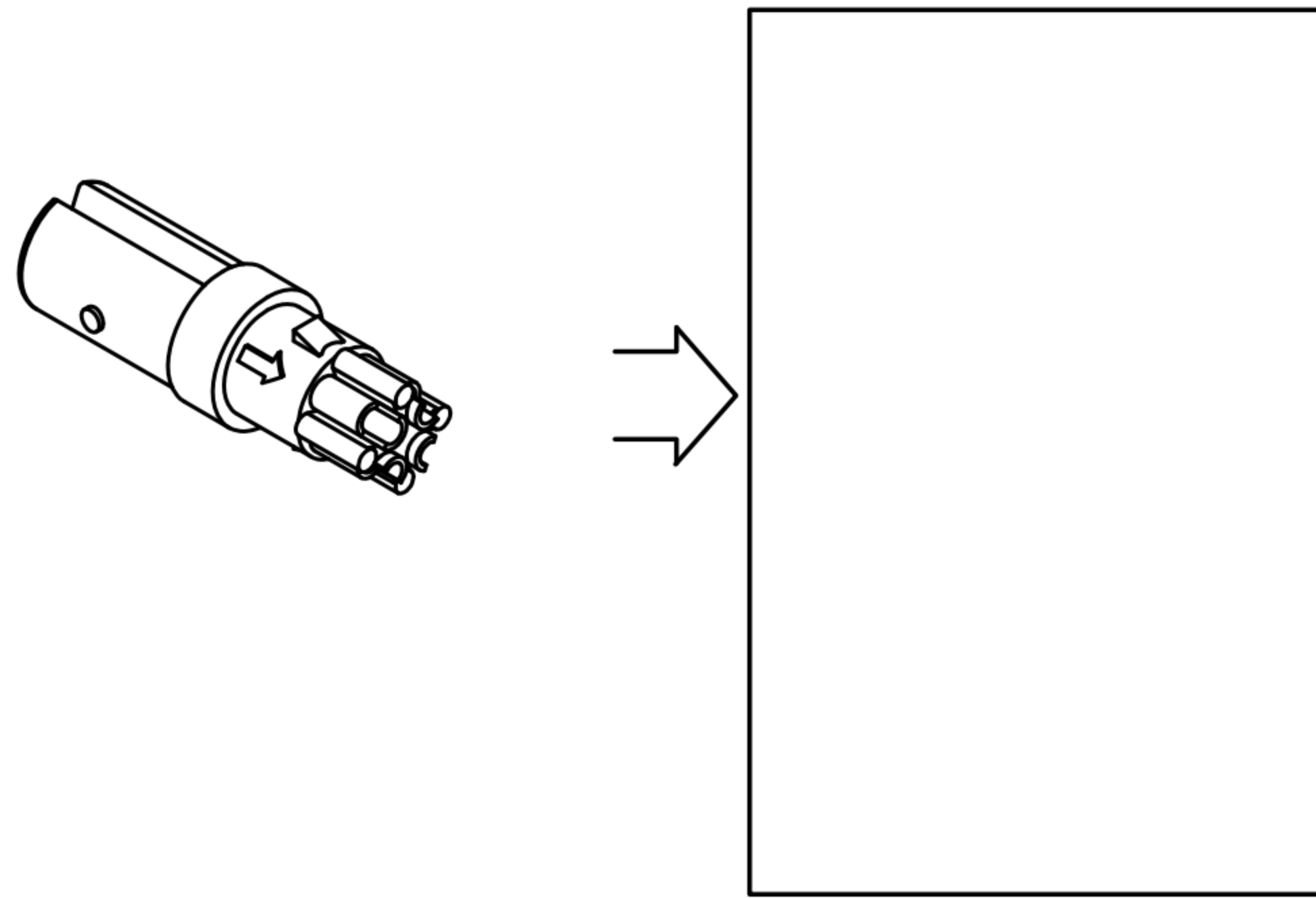

紙箱

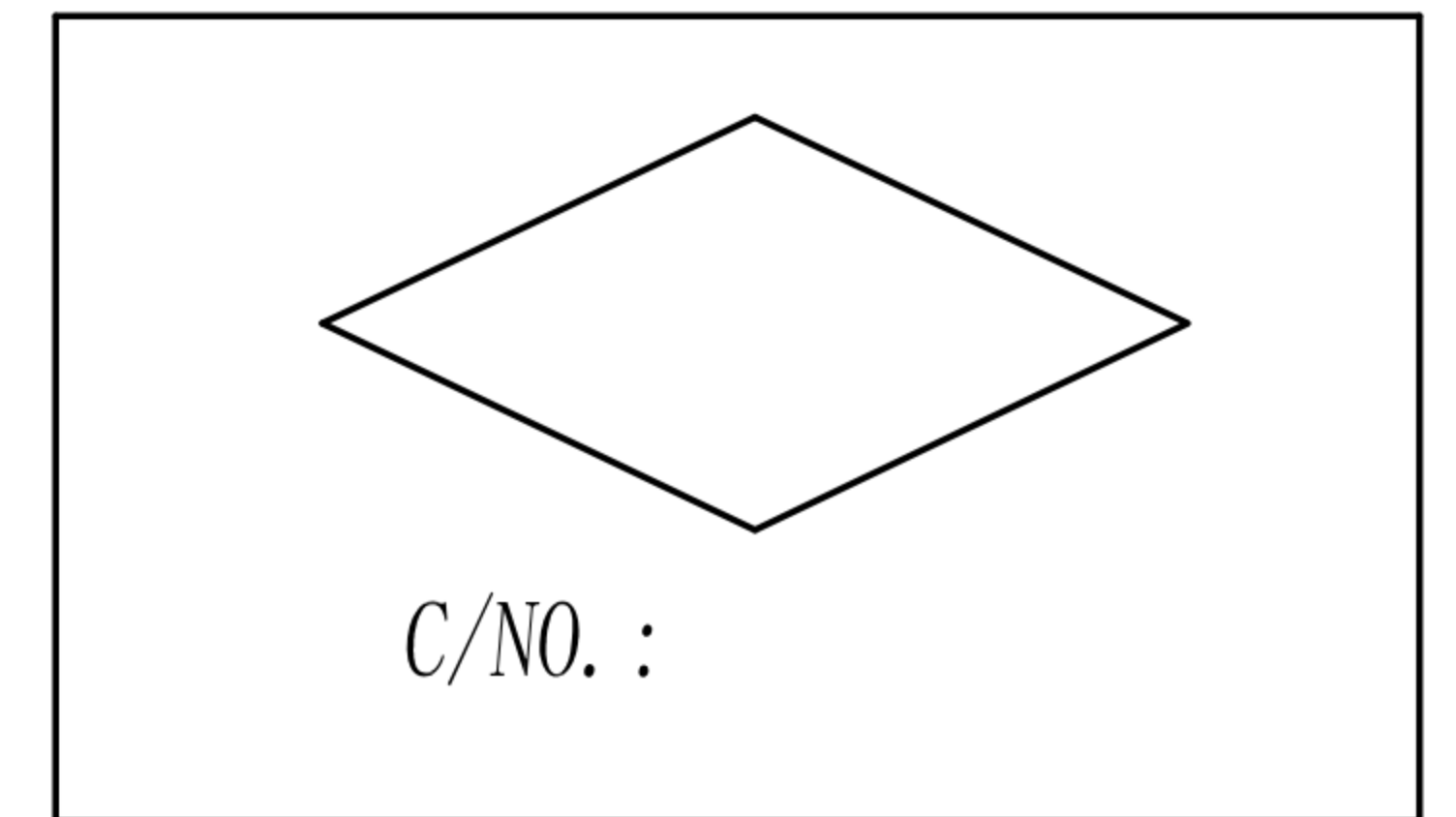
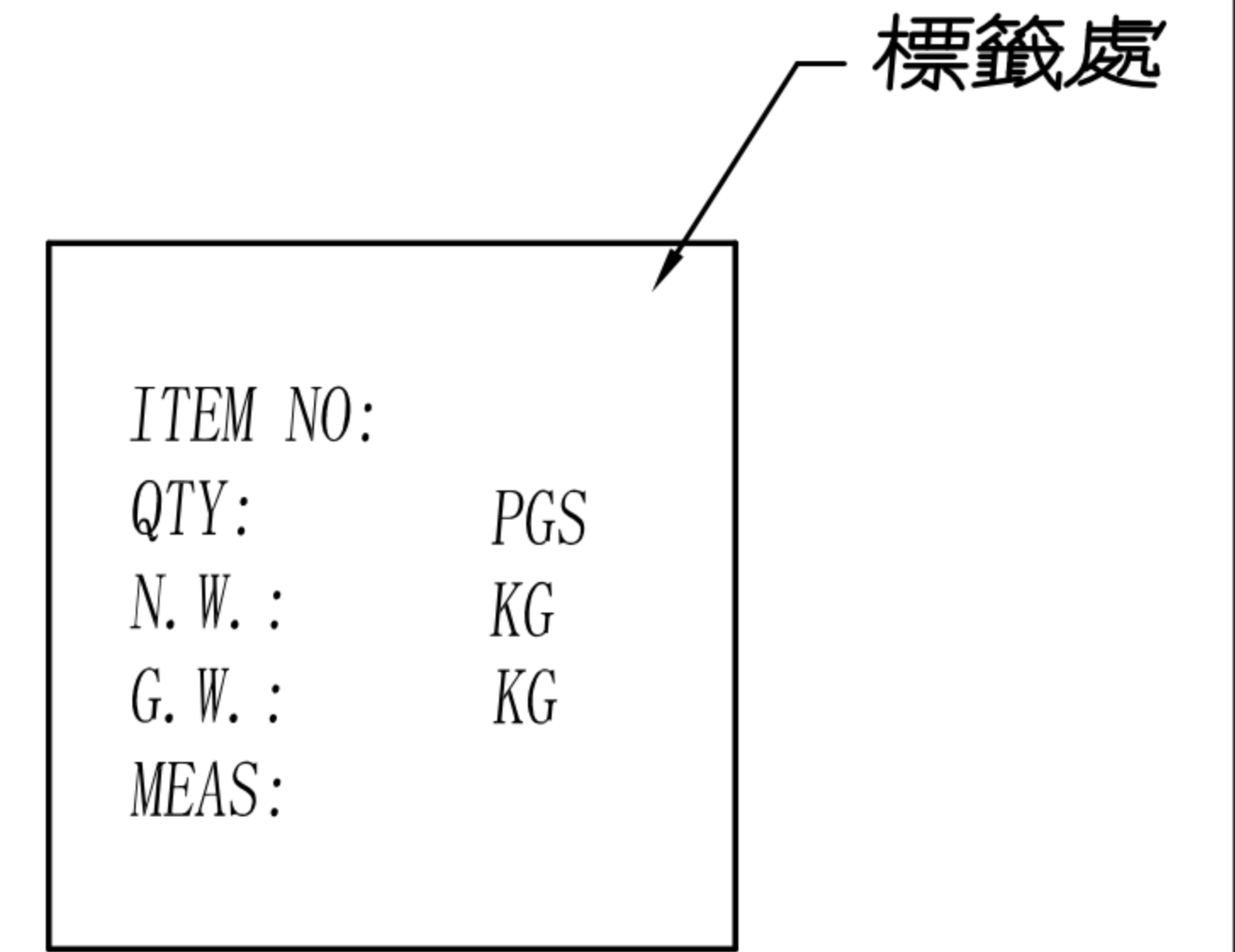

DRAWN	Sony Cui	APP'D	Emily Suen	UNIT	mm	TOLERANCE			TITLE	特4(F)成形式			SHEET	2/2
CHK'D	Emily Suen			SCALE	1:1	.x ±0.20 .xx ±0.10 .xxx ±0.05 .xxxx ±0.03 ANGULA ±1°			PART NO.	SPD-04F2-01	DWG NO.	QC5346	VERSION	A

CUSTOMER DRAWING

REV.	DESCRIPTION	APPROVED BY	DATE	ECN NO.
A	RELEASE	Emily Suen	23/03/11*	
B				
C				

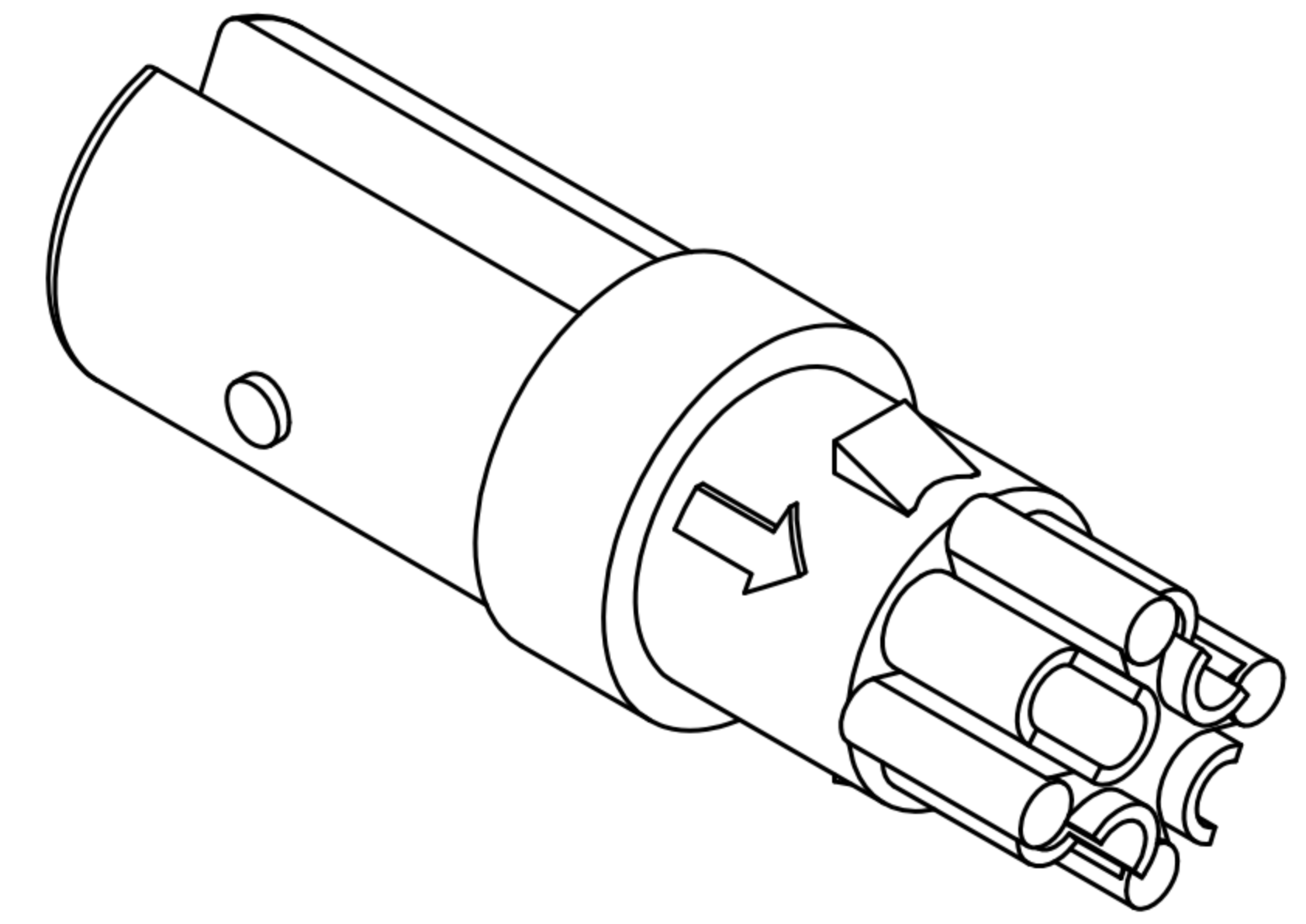
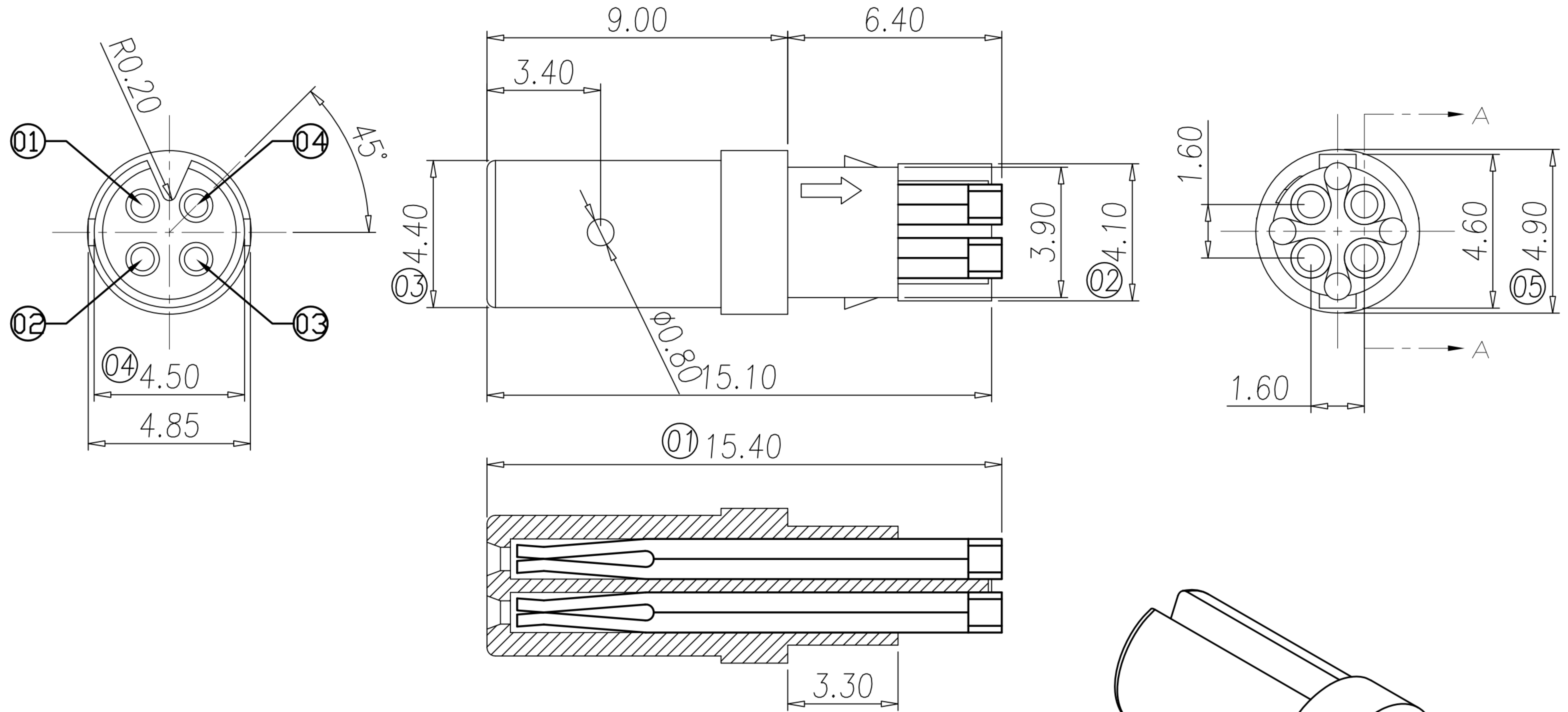

A-A 剖面

- MATERIAL :
 - 1-1. HOUSING : PBT UL94V-0 ; COLOR : BLACK
 - 1-2. CONTACT : PHOSPHOR BRONZE
- FINISH :
 - 2-1. CONTACT : SILVER 30u"
- ELECTRICAL SPECIFICATION :
 - 3-1. Rated current : 1A
 - 3-2. Rated voltage : 30V
- Environmental :
 - 4-1. Operation Temperature : -20℃~85℃

DRAWN	Sony Cui	APP'D	Emily Suen	UNIT	mm	TOLERANCE		广东科斯达电子科技有限公司 GUANG DONG KE SI DA ELECTRONIC TECHNOLOGY CO., LTD.	TITLE	特4(F)成形式			SHEET	1/2
CHK'D	Emily Suen			SCALE	1:1	.x ±0.20 .xx ±0.10 .xxx ±0.05 .xxxx ±0.03 ANGULA ±1°			PART NO.	SPD-04F2-01	DWG NO.	QC5346	VERSION	A