

CUSTOMER DRAWING

REV.	DESCRIPTION	APPROVED BY	DATE	ECN NO.
△A	RELEASE	Fido Weng	22/12/08*	
△B	改回正確電氣規格 & 新增料號	KU	29/03/19*	
△C				

TABLE A

MD-03F3-07-01	MD-04F2-15-11	MD-05F2-03-11
MD-06F2-10-11	MD-07F3-08-01	MD-08F2-03-11

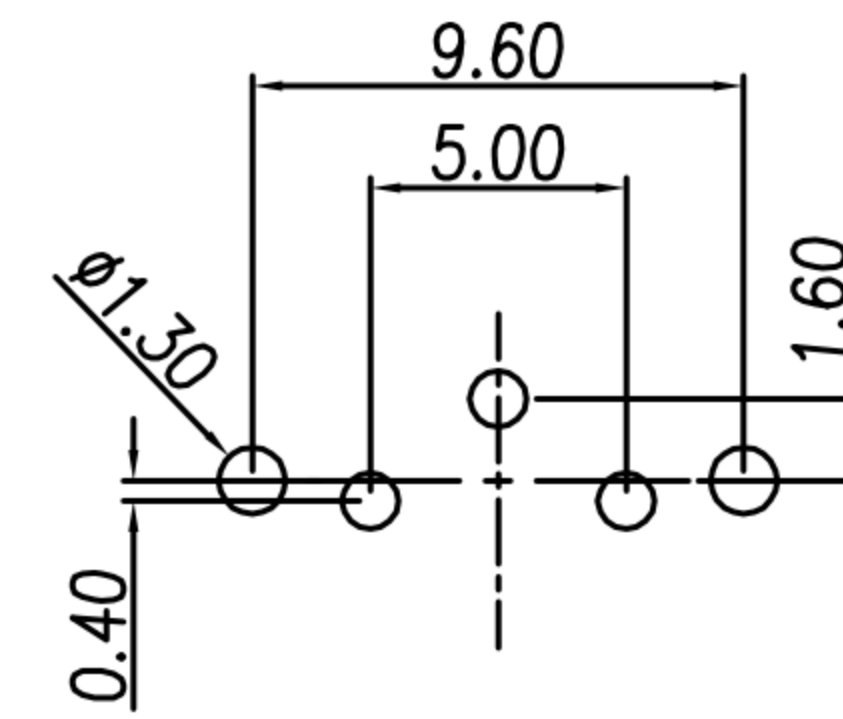
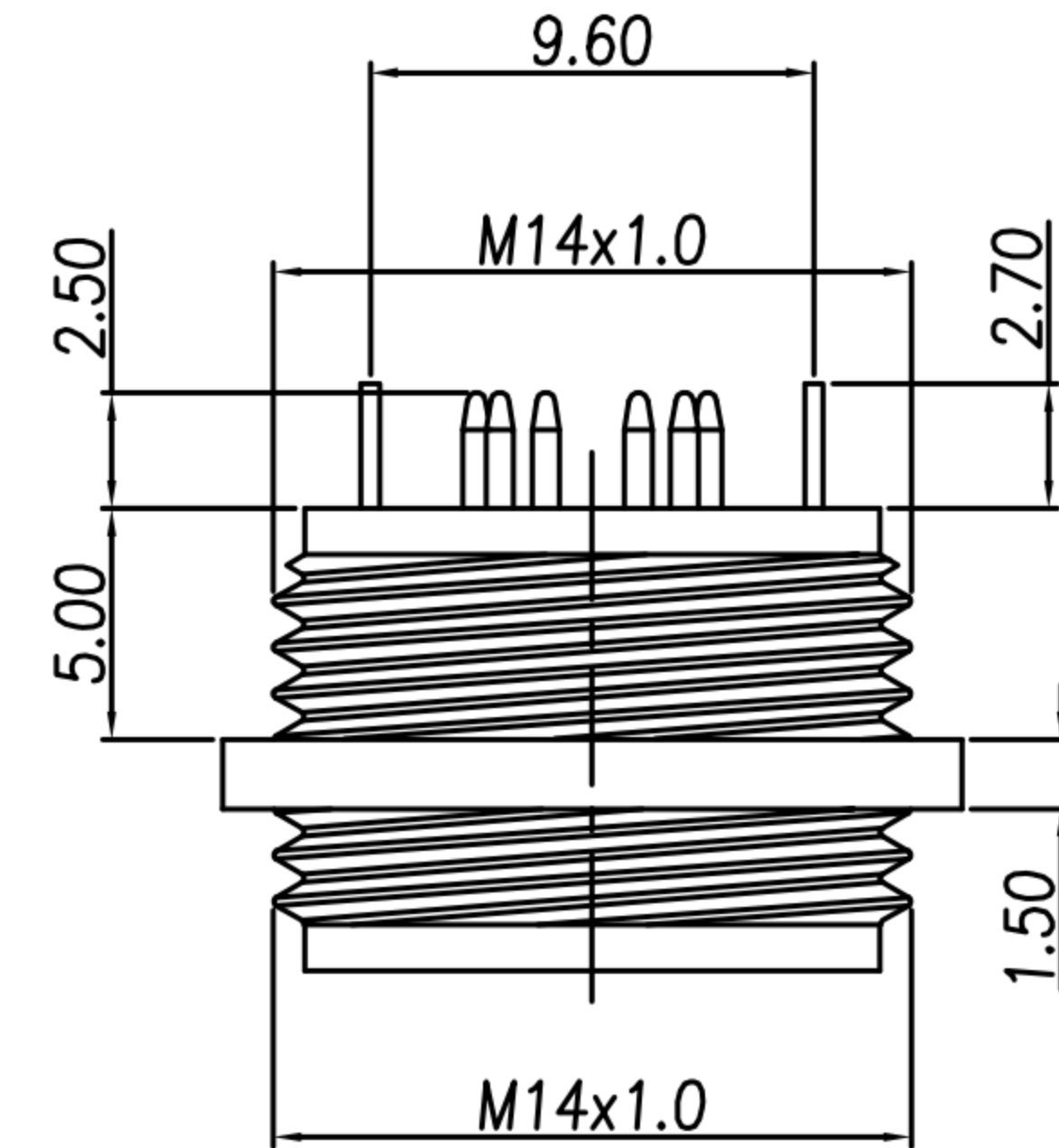
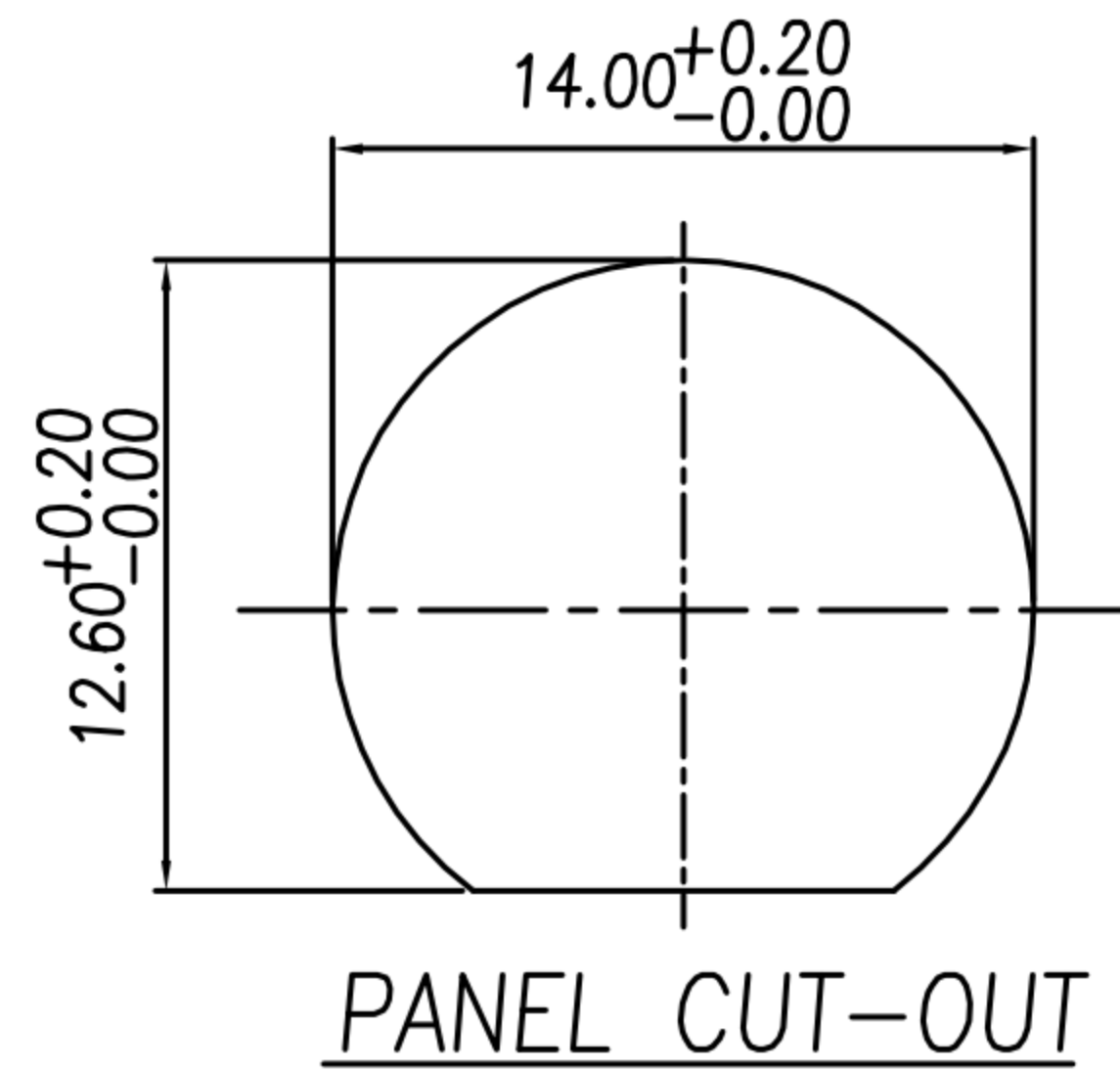

P.C.B LAYOUT

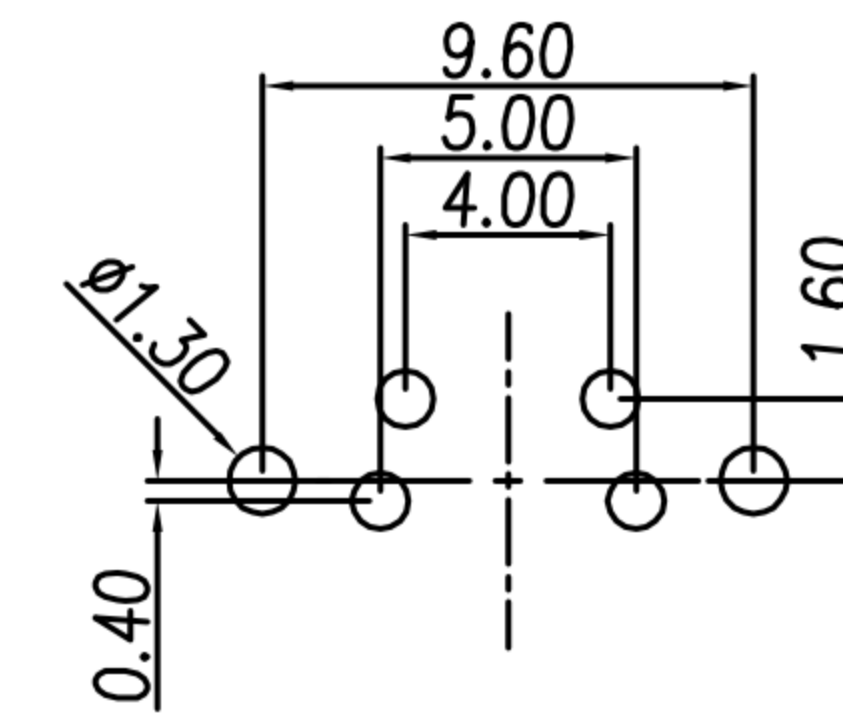

P.C.B LAYOUT

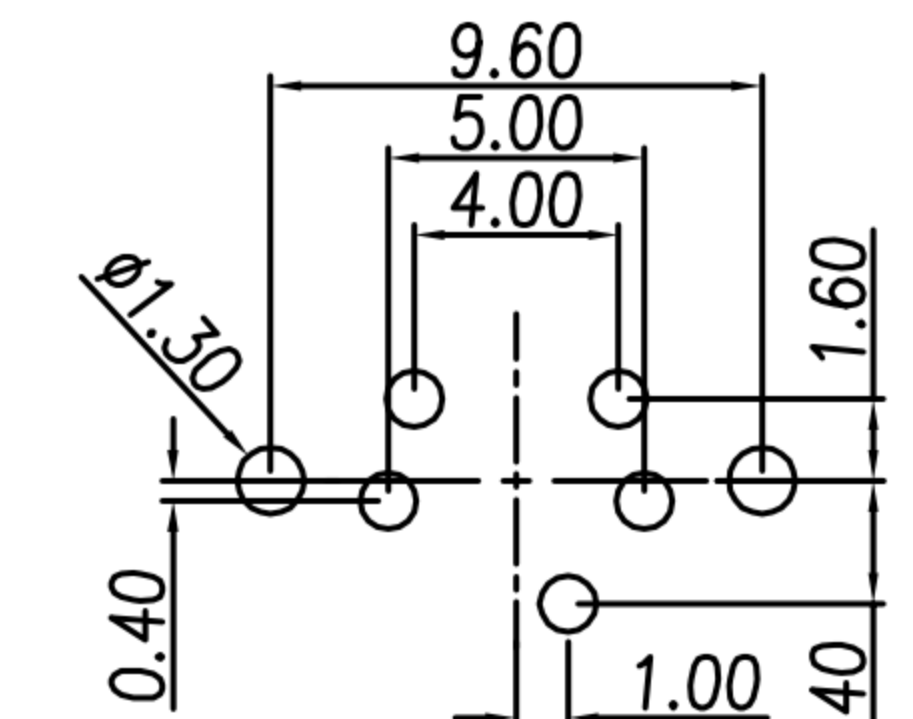

P.C.B LAYOUT

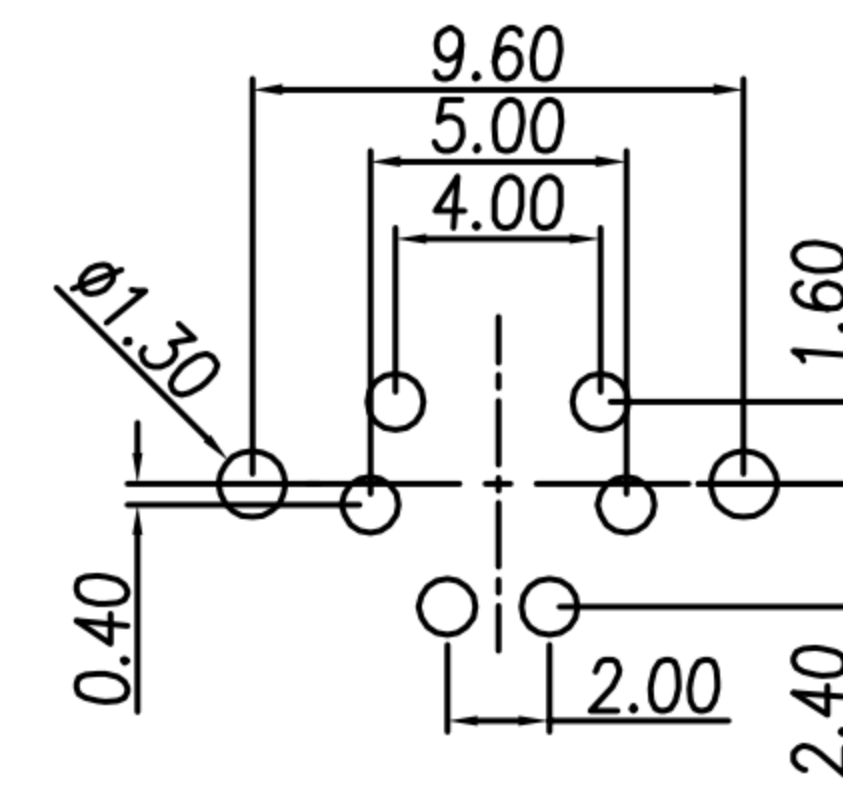

P.C.B LAYOUT

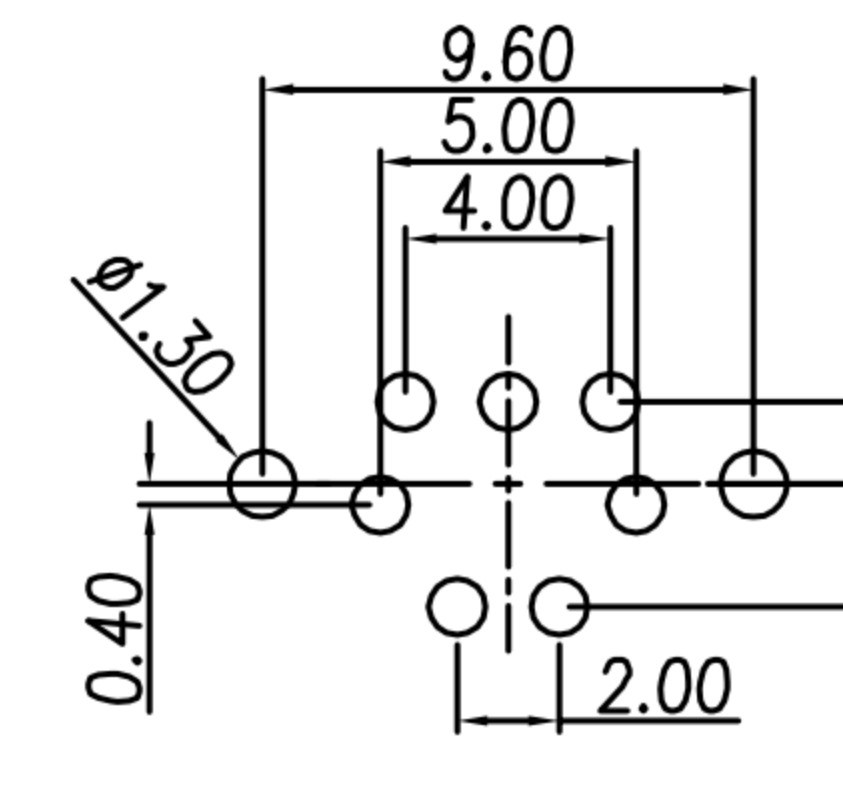

P.C.B LAYOUT

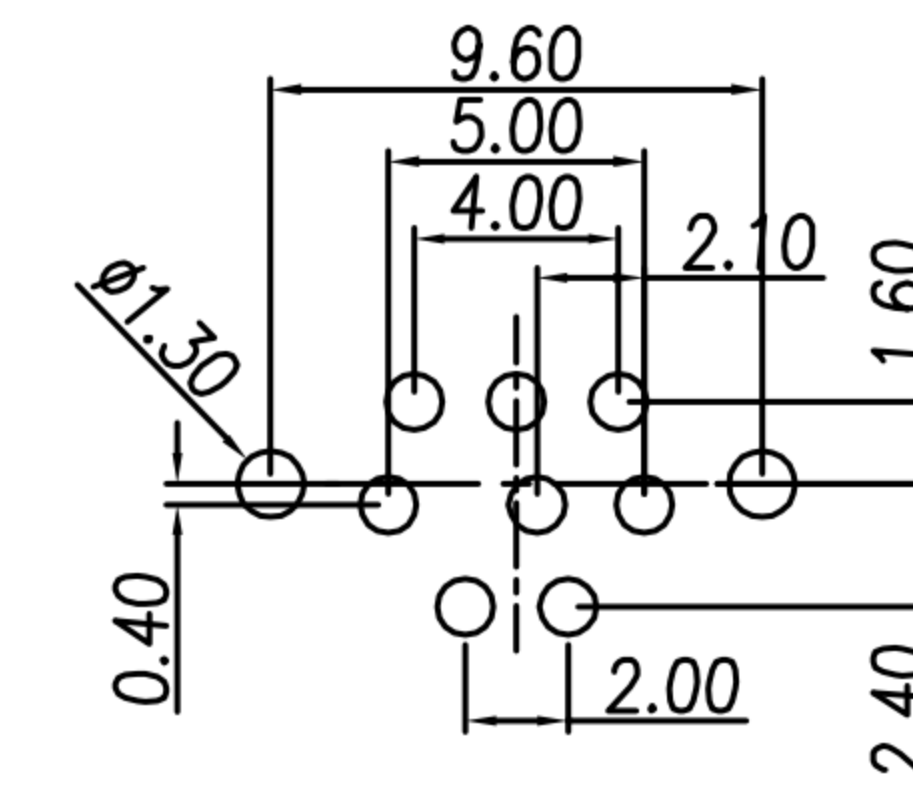

P.C.B LAYOUT

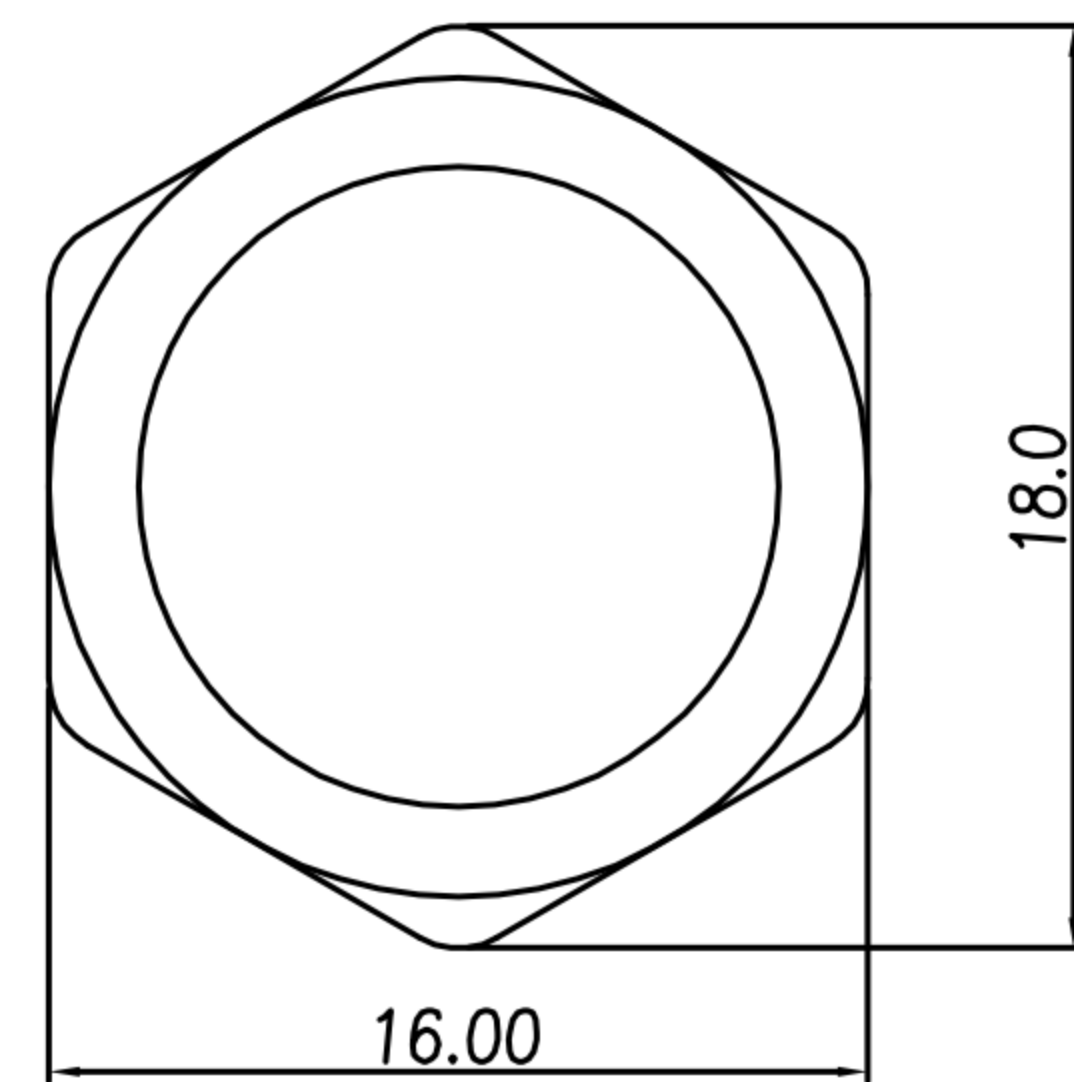
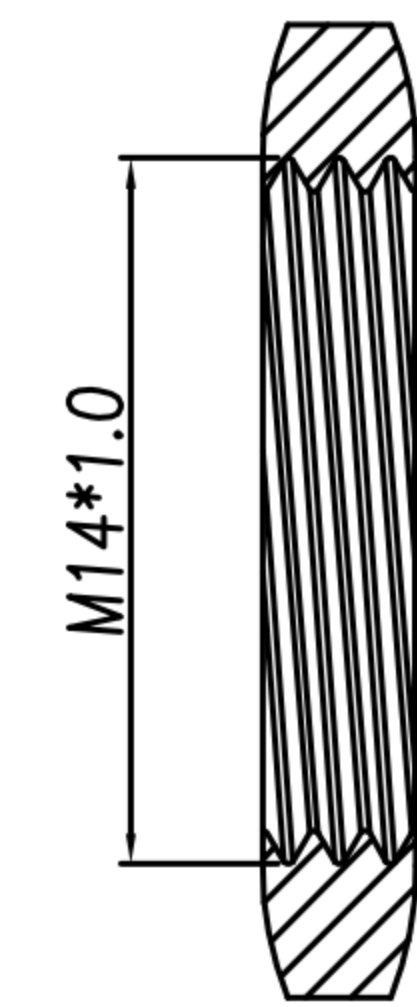

NUT

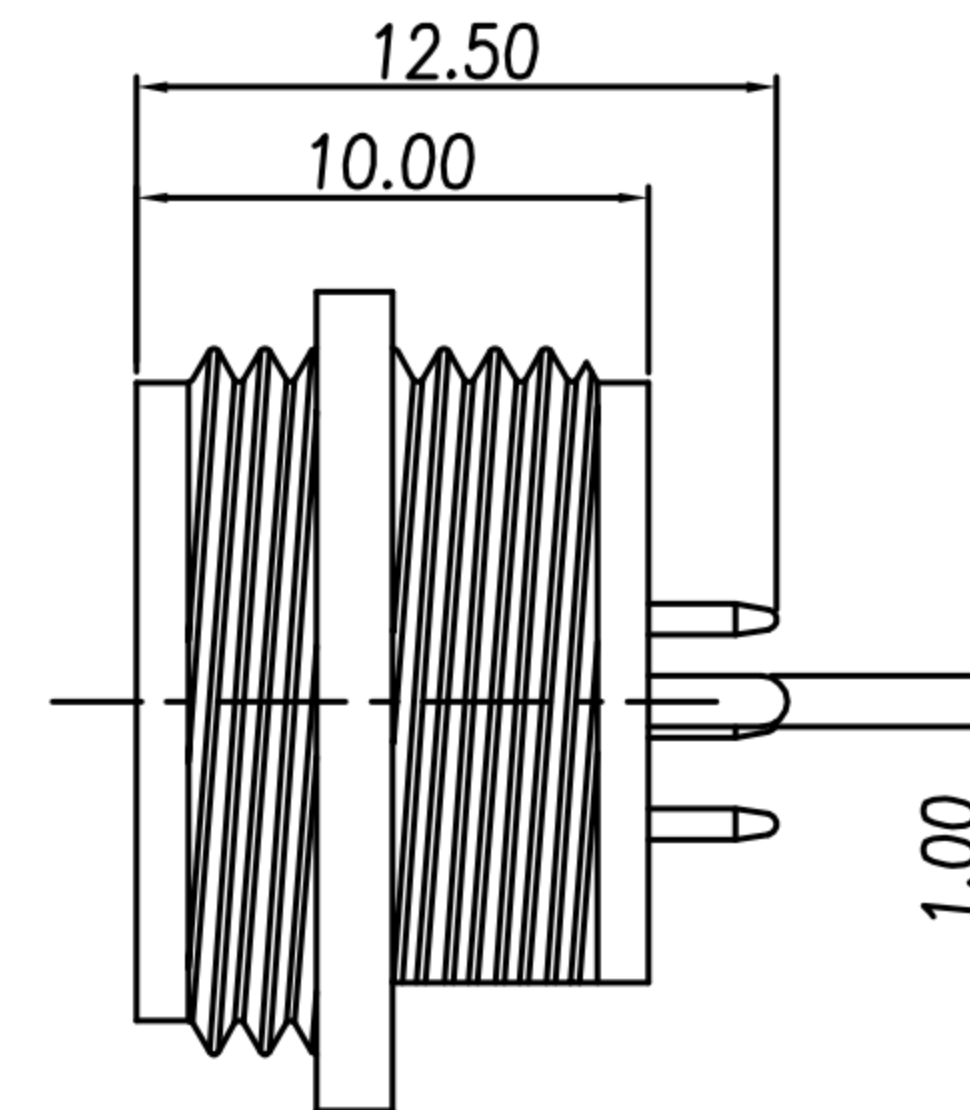
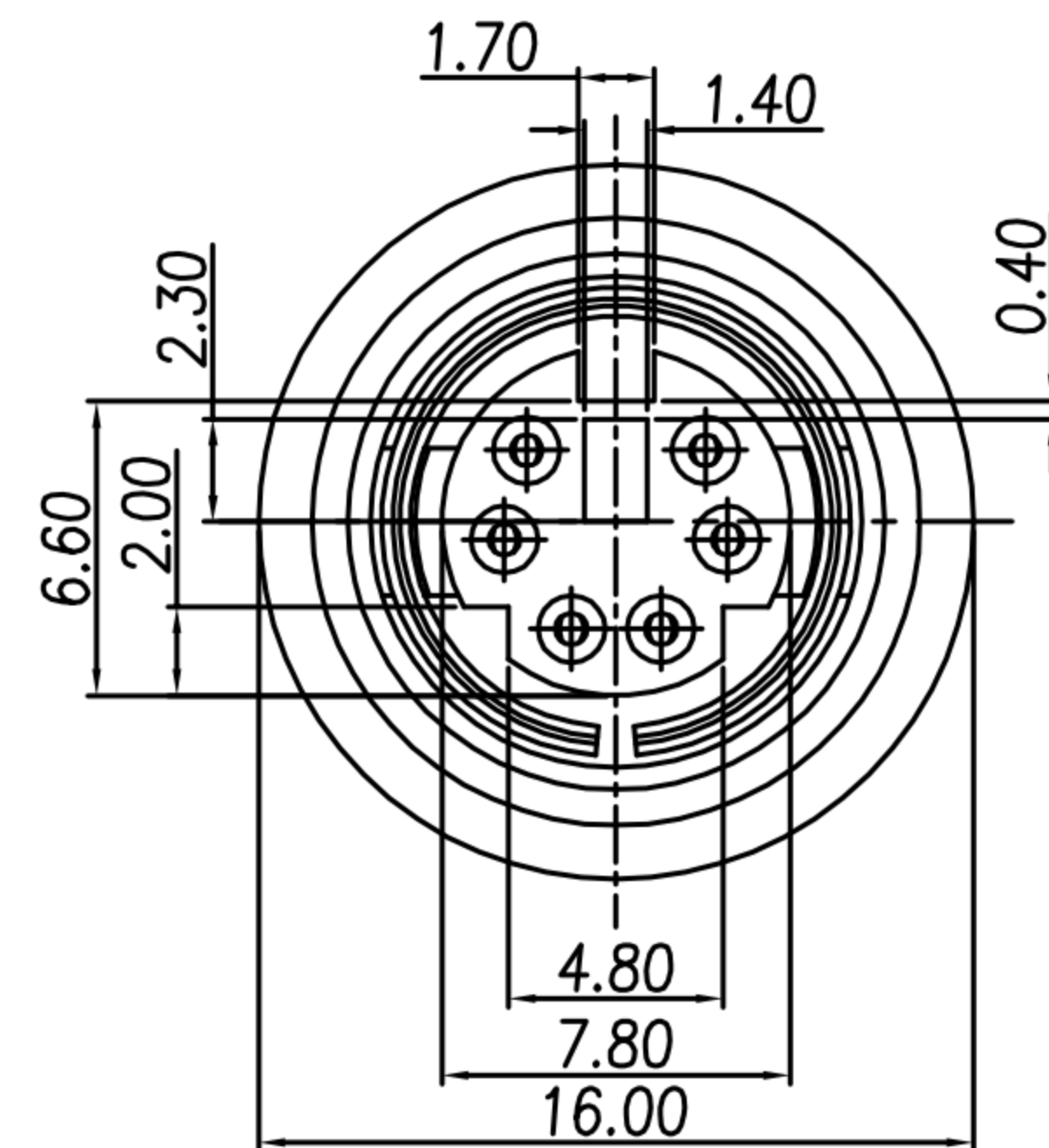

- MATERIAL :
 - Housing : PBT UL94V-0 ; Color : Black
 - Contact : Phosphor Bronze
 - Shell : Brass
- FINISH :
 - Contact : Bright Tin Plated
 - Shell : Nickel Plated
- ELECTRICAL SPECIFICATION :
 - Rated current : 2A
 - Rated voltage : 12v DC
 - Insulation Resistance : 50MΩ min. at 250V DC
 - Dielectric Strength : 250V AC / 1 minute
 - Contact Resistance : 30mΩ max.
 - Insertion force : 45N max.
 - Withdrawal force : 9N to 30N
 - Durability Test : 1000 Cycles
- Environmental :
 - Operation Temperature : -20℃~85℃

DRAWN	Yeh Chou	APP'D	Ku Chou	UNIT	mm	TOLERANCE		广东科斯达电子科技有限公司 GUANG DONG KE SI DA ELECTRONIC TECHNOLOGY CO., LTD.	TITLE	MiniDin (F) SOCKET SCREW DIP TYPE			SHEET	1
CHK'D	Emily Suen			SCALE	1:1				PART NO.	SEE TABLE A	DWG NO.	QC7056	VERSION	