

CUSTOMER DRAWING

REV.	DESCRIPTION	APPROVED BY	DATE	ECN NO.
N	新增TABLE A	Fido Weng	23/03/10"	
O	ADD NEW PART IN TABLE A	Fido Weng	22/10/10"	ECN10118
P	ADD NEW PART IN TABLE A	Fido Weng	03/06/13"	

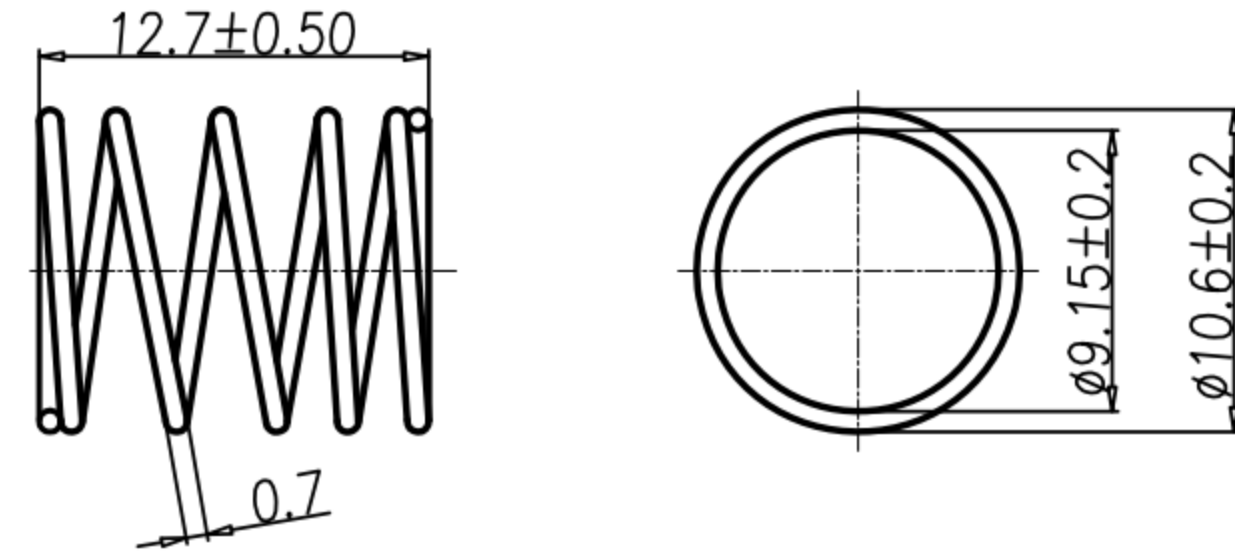

OS-DM0011 LOCK弹簧

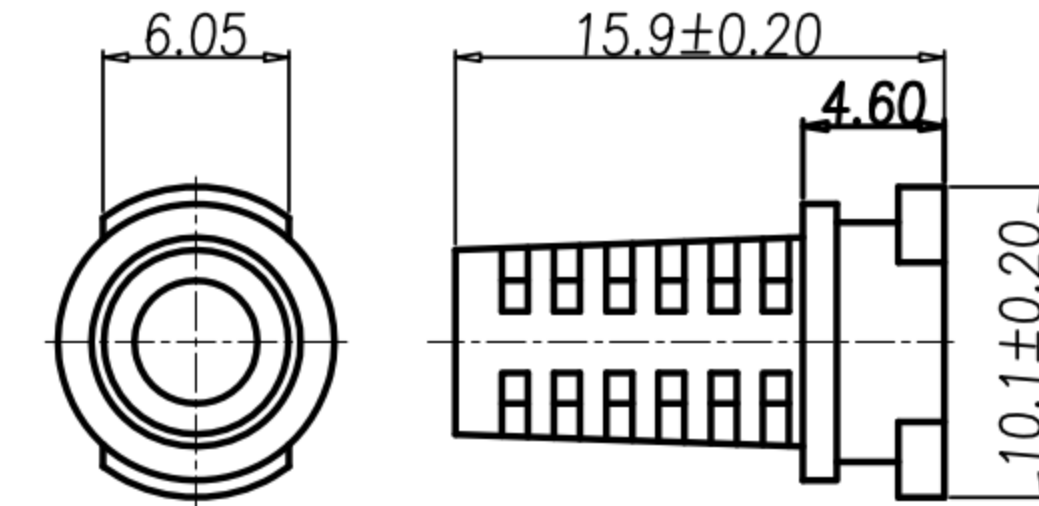

TABLE A

ON-DM0077	黑色	φ4.0
ON-DM0209	白灰色	φ4.0
PART NO.	COLOR	OD

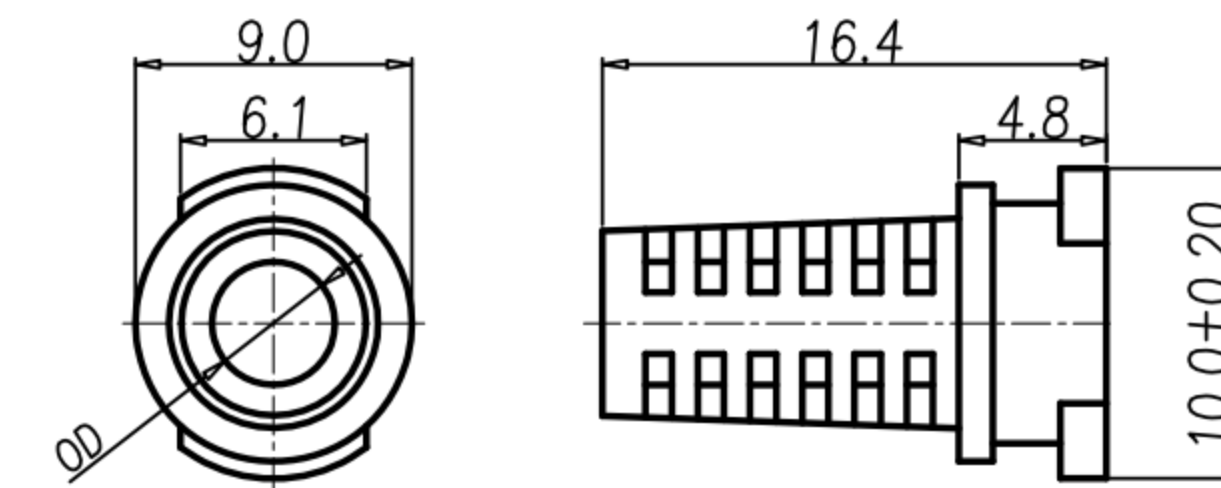
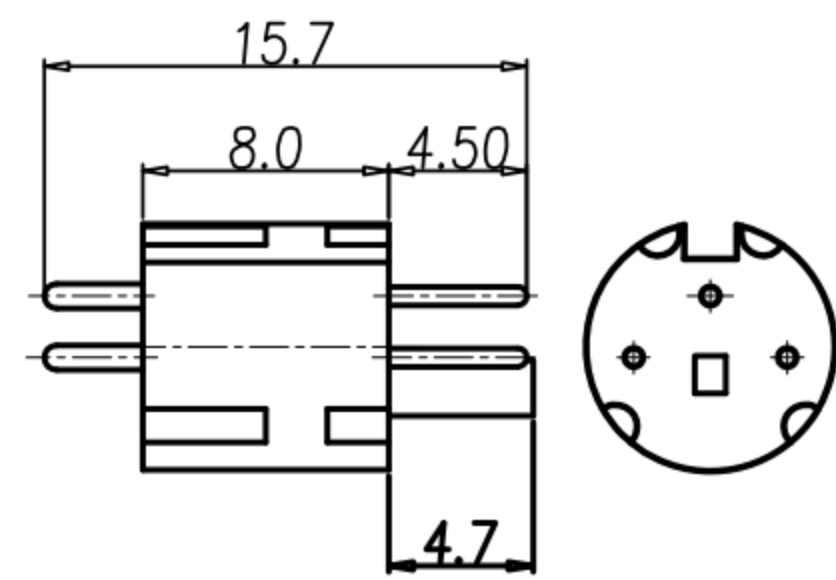

TABLE A

ON-DM0493-01	POWER SR(黑)	φ4.5
ON-DM0305	Power SR(貝吉)(WARM GRAY 3U)	φ6.5
ON-DM0258	Power SR(白灰)	φ5.5
ON-DM0217	Power SR(黑)	φ4.0
ON-DM0150	Power SR(白灰)	φ6.5
ON-DM0091	Power SR(貝吉)	φ6.5
ON-DM0018	Power SR(黑)	φ6.5
ON-DM0235	Power SR(貝吉黃)	φ5.5
ON-DM0249	Power SR(白)	φ5.5
ON-DM0208	Power SR(貝吉)	φ5.5
ON-DM0071	Power SR(黑)	φ5.5
ON-DM0072	Power SR(黑)	φ7.0
ON-DM0210	POWER SR(白灰)	φ5.0
ON-DM0079	POWER SR(黑)	φ5.0
P/N	DESCRIPTION	D



3PIN HOUSING+PIN

TABLE A	
NY-DM608	GOLD/金30u"
NY-DM101	GOLD FLASH/鍍金

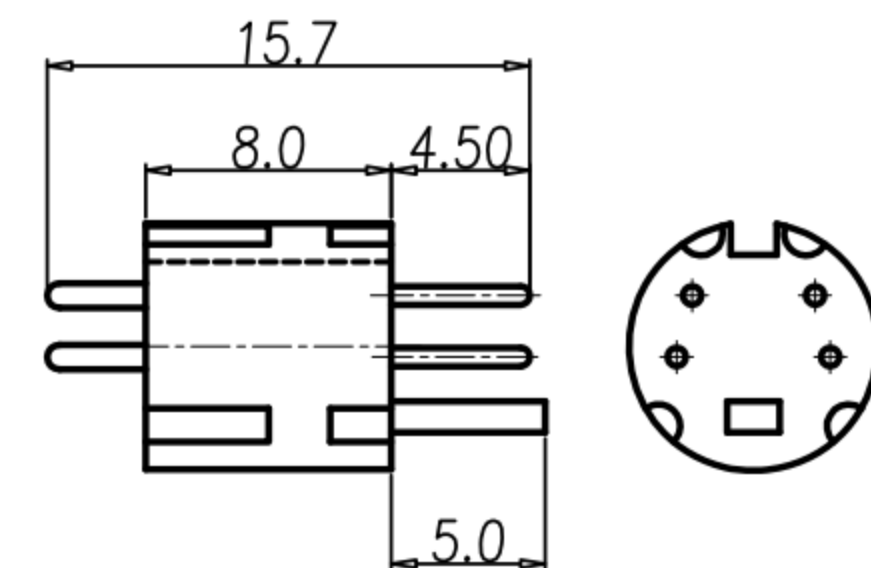

4PIN HOUSING+PIN

TABLE A	
NY-DM576	GOLD/金30u"
NY-DM102	GOLD FLASH/鍍金

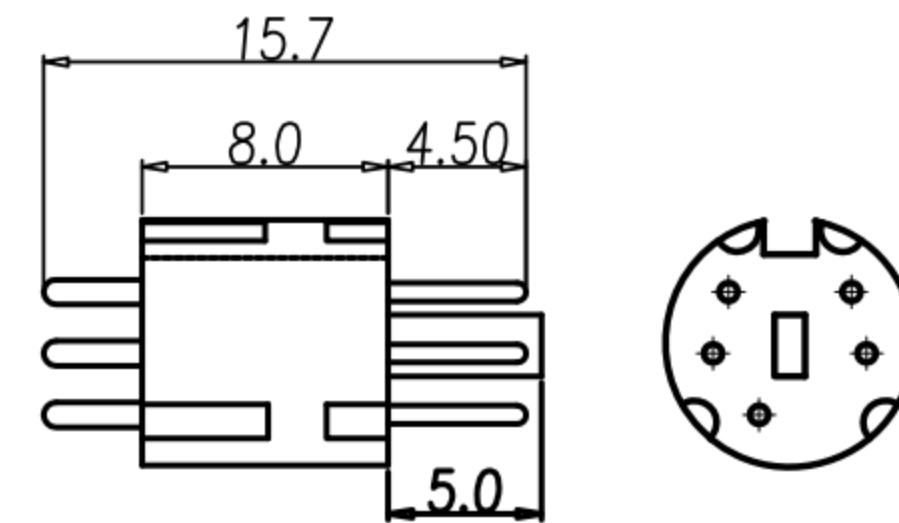

5PIN HOUSING+PIN

TABLE A/表A	
NY-DM103	GOLD FLASH/鍍金

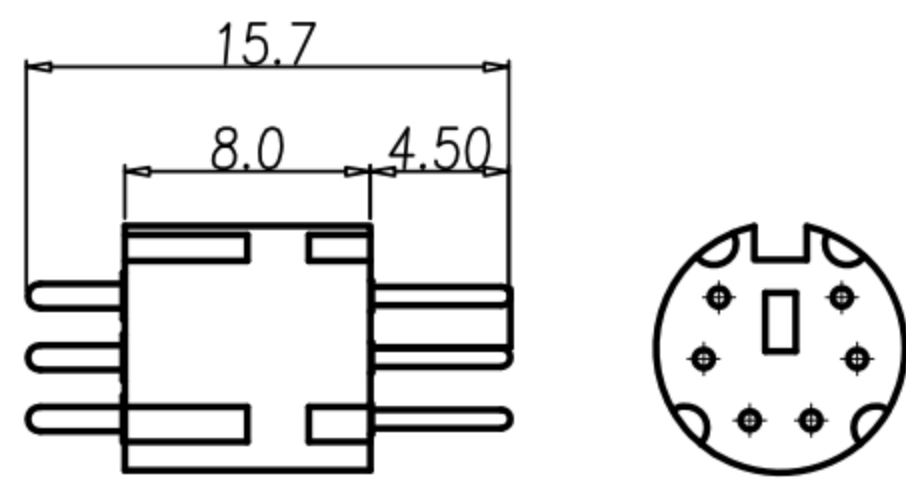

6PIN HOUSING+PIN

TABLE A	
NY-DM104	鍍金/GOLD FLASH
NY-DM362	金30u"/GOLD 30u"
NY-DM424	金15u"/GOLD 15u"
P/N	PLATED

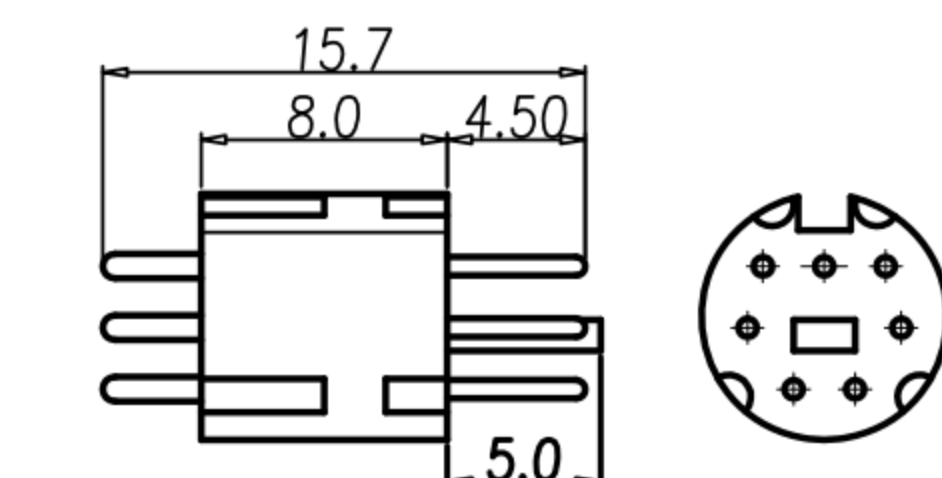

7PIN HOUSING+PIN

TABLE A	
NY-DM105	鍍金/GOLD FLASH
NY-DM419	金30u"/GOLD 30u"
P/N	PLATING

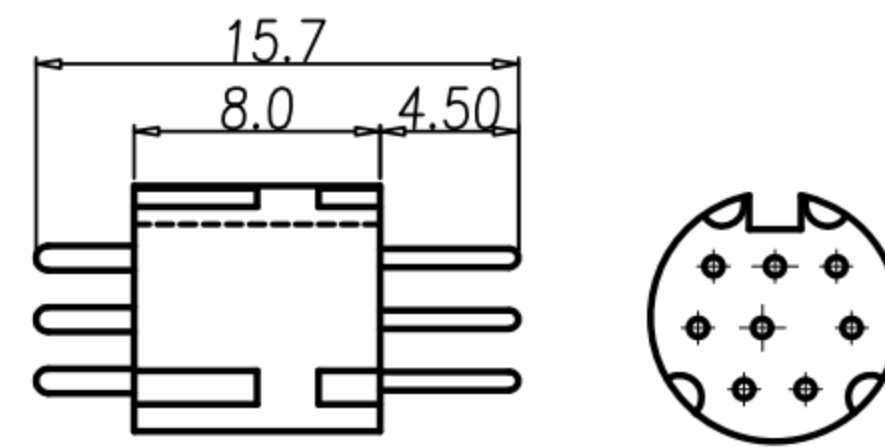

8PIN HOUSING+PIN

TABLE A	
NY-DM106	鍍金/GOLD FLASH
NY-DM363	金30u"/GOLD 30u"
P/N	PLATED

DRAWN	Emily Suen	APP'D	Fido Weng	UNIT	mm	TOLERANCE			TITLE	SEE TABLE A			SHEET	3/3
CHK'D	Emily Suen			SCALE	1:1				PART NO.	SEE TABLE A	DWG NO.	QC1009	VERSION	P

广东科斯达电子科技有限公司
GUANG DONG KE SI DA ELECTRONIC TECHNOLOGY CO., LTD.

CUSTOMER DRAWING

REV.	DESCRIPTION	APPROVED BY	DATE	ECN NO.
△	ADD NEW PART IN TABLE A	Fido Weng	22/10/10"	ECN10118
△	ADD NEW PART IN TABLE A	Fido Weng	03/06/13"	
△	增加料號	KU	17/04/18"	

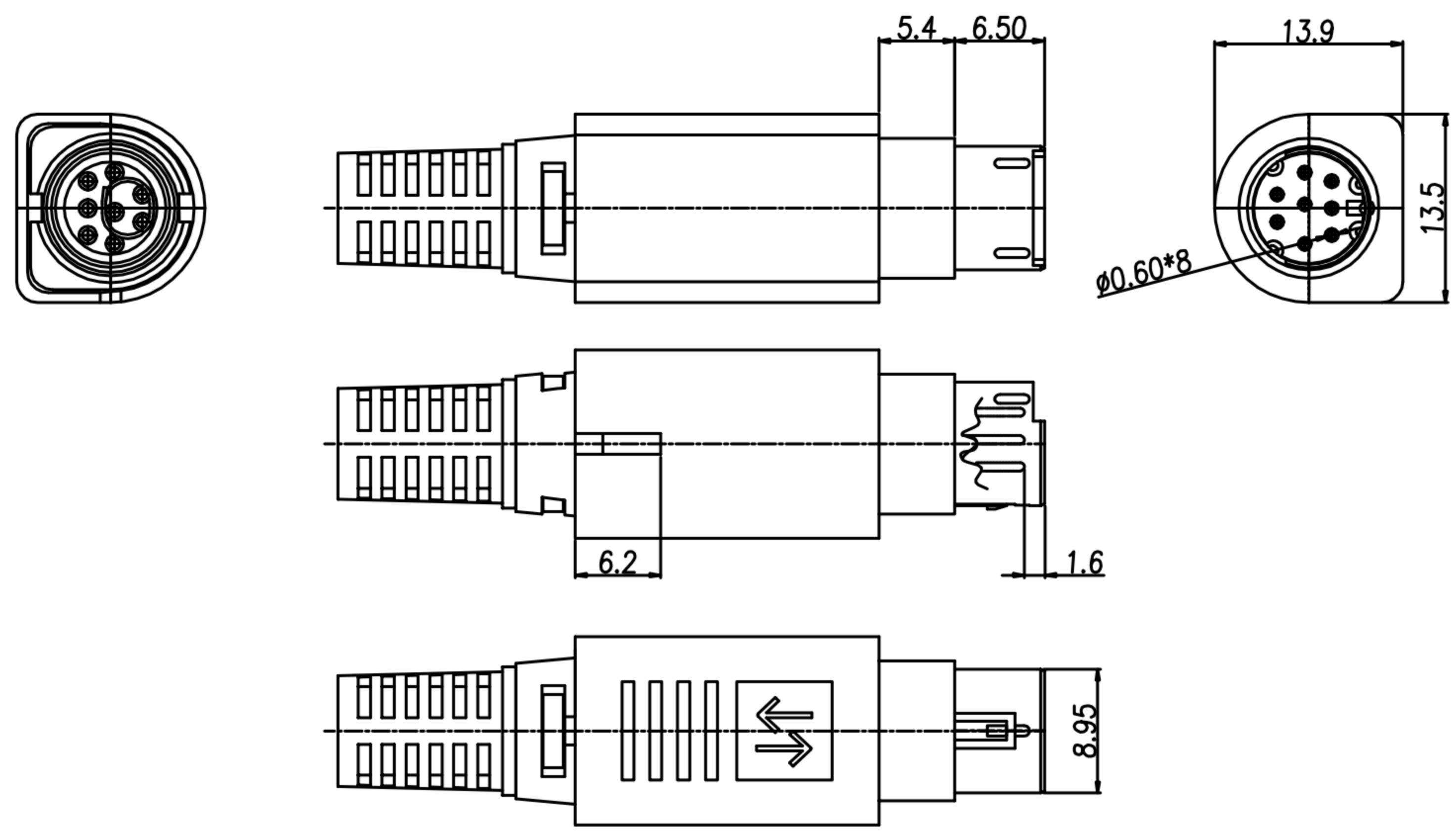
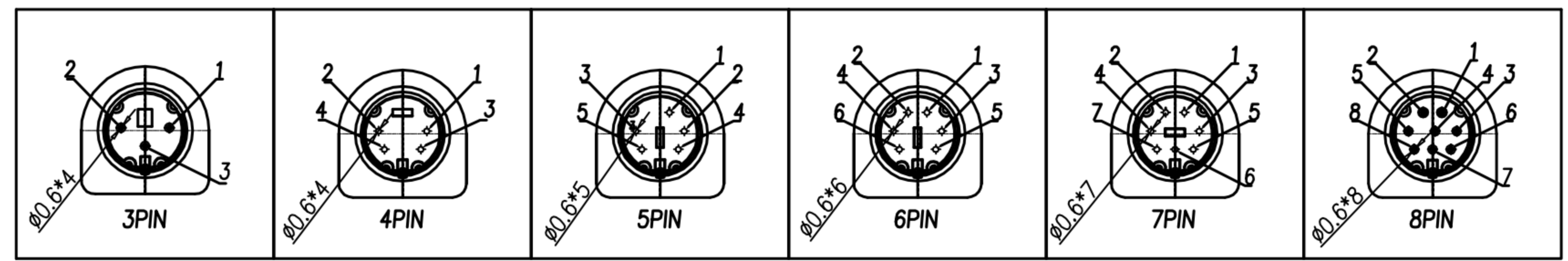

TABLE A

PART No.	TITLE	SR	銅管下蓋
MD-03M2-08	MiniDin 3(M)Lock 裝配八件式	SR OD=6.5	H=8.7
MD-03M2-06	MiniDin 3(M)Lock 裝配八件式	SR OD=4.0	H=8.7
MD-03M2-05	MiniDin 3(M)Lock 裝配八件式	SR OD=5.5	H=8.7
MD-03M2-04	MiniDin 3(M)Lock 裝配八件式	SR OD=5.0	H=8.7
MD-04M2-27-11	LOCK 4P 銅管下蓋 H=8.7	SR OD=4.5	H=8.7
MD-04M2-24-11	LOCK 4P 銅管下蓋 H=5.6	SR OD=4.5	H=5.6
MD-04M2-12	MiniDin 4(M)Lock 裝配式	SR OD=7.0	H=8.7
MD-04M2-11	MiniDin 4(M)Lock 裝配八件式	SR OD=4.0	H=8.7
MD-04M2-10	LOCK 4P	SR OD=5.0	H=8.7
MD-04M2-09	LOCK 4P	SR OD=5.5	H=8.7
MD-04M2-08	LOCK 4P	SR OD=6.5	H=8.7
MD-05M2-16-11	MiniDin 5(M)Lock 裝配六件式(無SR)		
MD-05M2-11	Lock 5P	SR OD=6.5	H=8.7
MD-05M2-10	Lock 5P	SR OD=7.0	H=8.7
MD-05M2-08	Lock 5P	SR OD=3.5	H=8.7
MD-05M2-07	Lock 5P	SR OD=5.0	H=8.7
MD-05M2-06	Lock 5P	SR OD=5.5	H=8.7
MD-06M2-68	MiniDin 6(M)Lock 白灰色八件式雙箭SR5.5	SR OD=5.5	H=8.7
MD-06M2-53	MiniDin 6(M)Lock 八件式雙箭SR5.5	SR OD=5.5	H=8.7
MD-06M2-08	MiniDin 6(M)Lock 裝配式	SR OD=5.0	H=8.7
MD-06M2-07	LOCK 6P	SR OD=6.5	H=8.7
MD-07M2-09	LOCK 7P 金30u"	SR OD=6.5	H=8.7
MD-07M2-02	LOCK 7P 表金	SR OD=6.5	H=8.7
MD-08M2-37-11	LOCK 8P(無SR)		H=8.7
MD-08M2-35	MiniDin 8(M)Lock 裝配七件式雙箭(無SR)		H=8.7
MD-08M2-33	MiniDin 8(M)Lock 裝配八件式	SR OD=4.0	H=8.7
MD-08M2-31	MiniDin 8(M)Lock 裝配式(綠色)	SR OD=6.5	H=8.7
MD-08M2-30	MiniDin 8(M)Lock 裝配式(紫色)	SR OD=6.5	H=8.7
MD-08M2-18	MiniDin 8(M)Lock 裝配式(紅色)	SR OD=6.5	H=8.7
MD-08M2-16	MiniDin 8(M)Lock 裝配式雙箭	SR OD=7.0	H=8.7
MD-08M2-15	LOCK 8P 金 30u"	SR OD=6.5	H=8.7
MD-08M2-14	MiniDin 8(M)Lock 裝配式(黑色)	SR OD=5.5	H=8.7
MD-08M2-12	MiniDin 8(M)Lock 裝配式	SR OD=6.5	H=8.7
MD-08M2-11	LOCK 8P	SR OD=6.5	H=8.7
MD-08M2-10	MiniDin 8(M)Lock 裝配式	SR OD=5.0	H=8.7

NOTE :

- MATERIAL :
 - 1-1. PLASTIC COVER : ABS.
 - 1-2. SHELL : BRASS
 - △ 1-3. POM RING: POM.
 - 1-4. HOUSING: PBT
 - 1-5. CONTACT : BRASS
 - 1-6. SPRING : STEEL
 - 1-7. METAL CAP : BRASS
 - 1-8. TUBE : PC △
 - 1-9. SR: PVC.
- FINISH :
 - 2-1. SHELL : NICKEL PLATED OVER ALL
 - 2-2. CONTACT : GOLD FLASH PLATED
 - 2-3. SPRING : NICKEL PLATED OVER ALL
 - 2-4. METAL CAP : NICKEL PLATED OVER ALL
- ELECTRICAL SPECIFICATION :
 - 3-1. RATED CURRENT : 1A
 - 3-2. RATED VOLTAGE : 100V
 - 3-3. DIELECTRIC STRENGTH : 250V AC / 1 minute
- ENVIRONMENTAL :
 - 4-1. OPERATION TEMPERATURE : -20°~85°



DRAWN	Emily Suen	APP'D	Fido Weng	UNIT	mm	TOLERANCE		广东科斯达电子科技有限公司 GUANG DONG KE SI DA ELECTRONIC TECHNOLOGY CO., LTD.	TITLE	SEE TABLE A			SHEET	1/3
CHK'D	Emily Suen			SCALE	1:1	.x ±0.20 .xx ±0.10 .xxx ±0.05 .xxxx ±0.03 ANGULA ±1°			PART NO.	SEE TABLE A	DWG NO.	QC1009	VERSION	Q

