

CUSTOMER DRAWING

REV.	DESCRIPTION	APPROVED BY	DATE	ECN NO.
△A	RELEASE	Yeh Chou	2017/xx/xx	
△B				
△C				
△D				

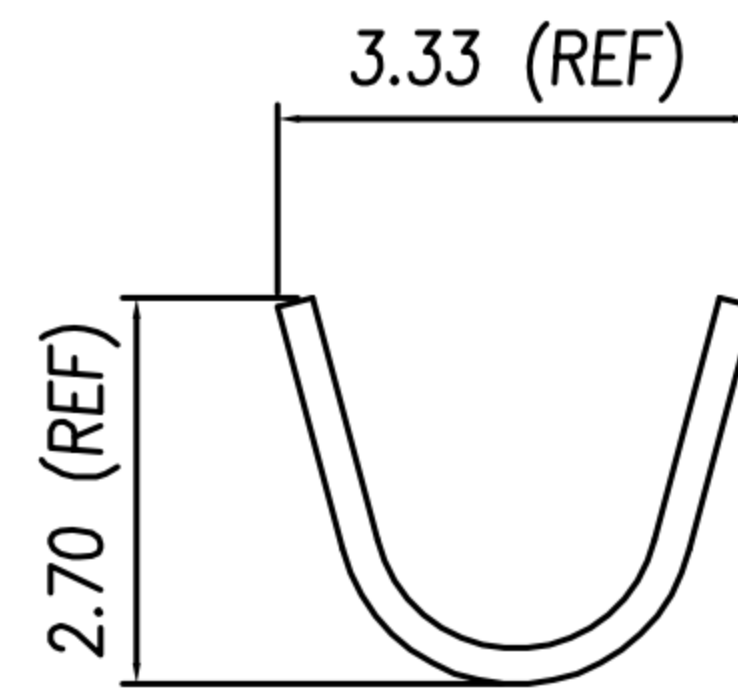

A-A

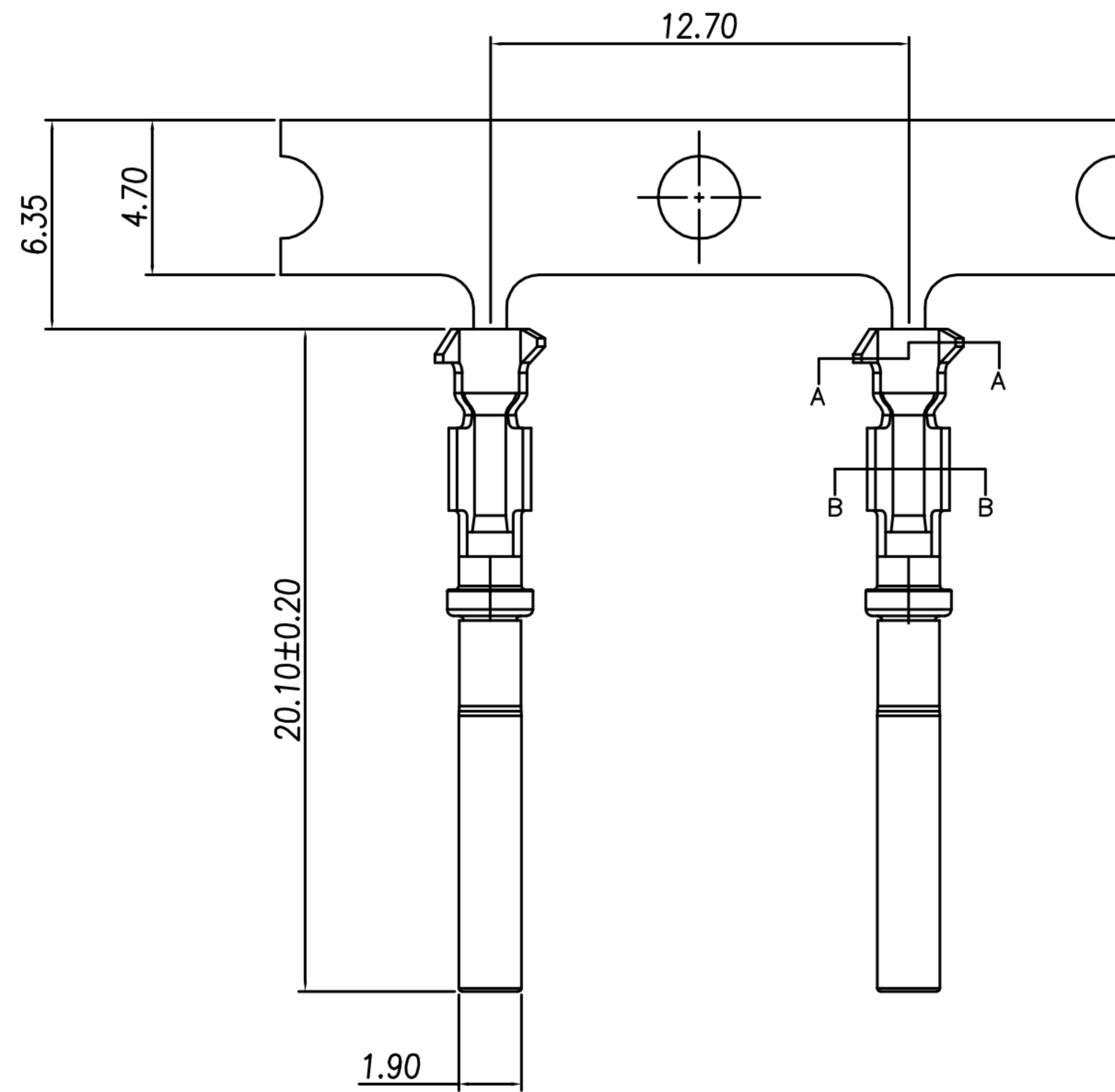
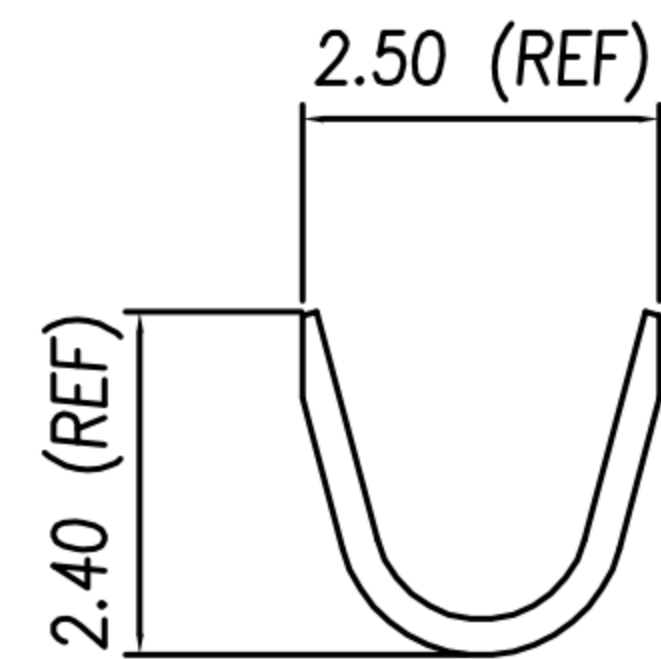

B-B

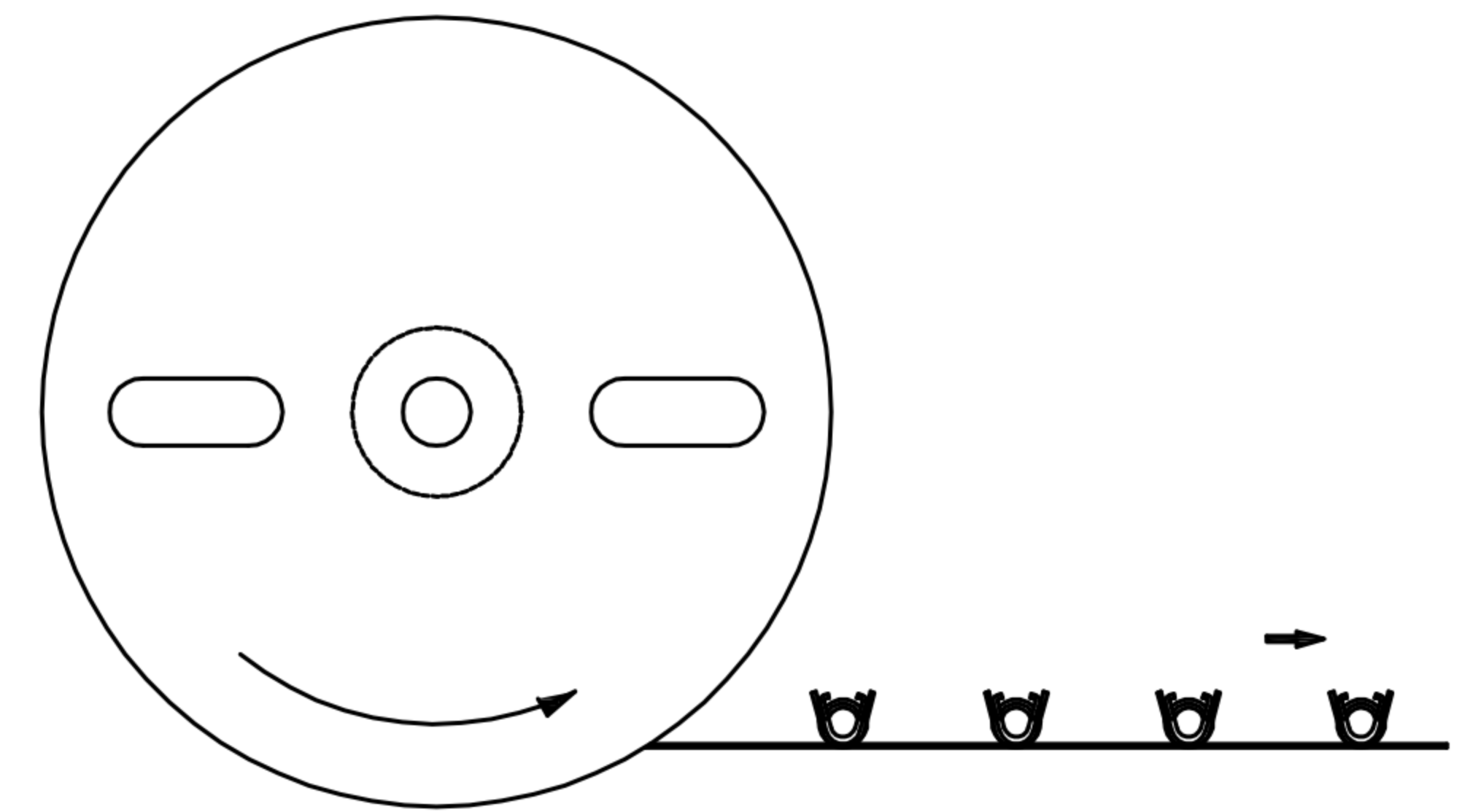
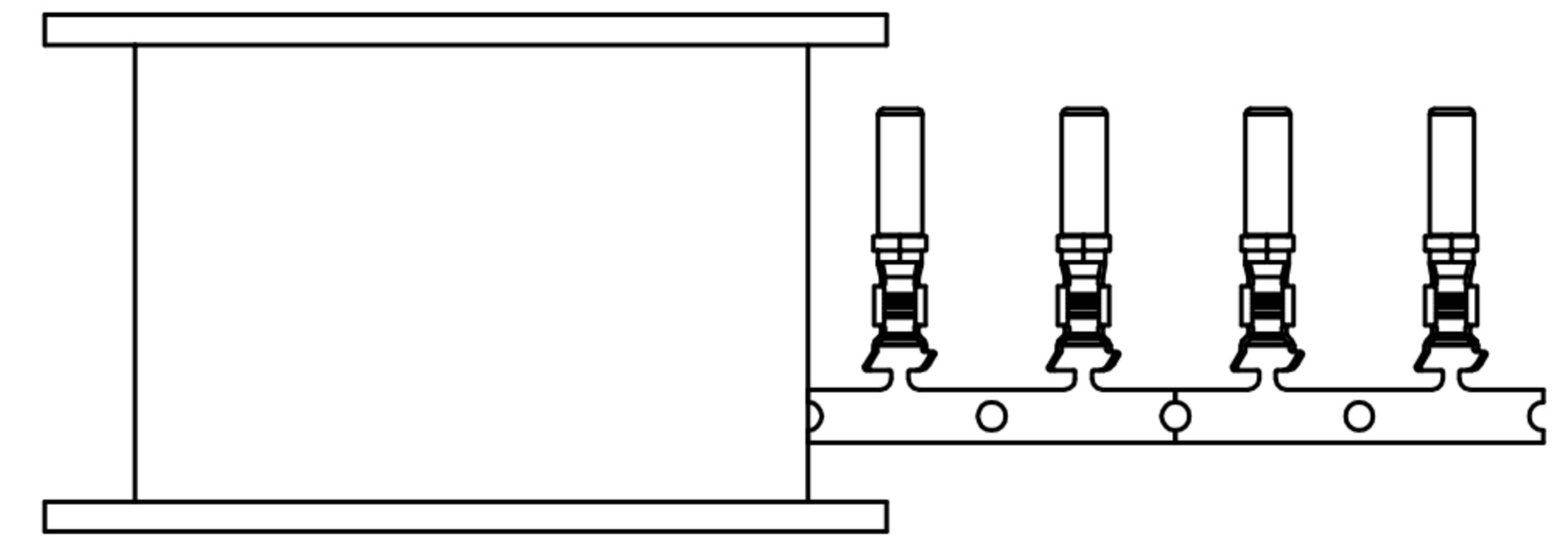

PULL OUT DIRECTION

TABLE A

NY-WP1038-00	防水頭12PIN (F) 端子半成品(Crimp PIN 20~28AWG)	MATTE TIN 80u"~100u"
NY-WP1037-00	防水頭12PIN (F) 端子半成品(Crimp PIN 20~28AWG)	NICKEL 80u"~100u"
P/N	TITLE	FINISH

- MATERIAL :
 - CONTACT : PHOSPHOR BRONZE
 - SHELL : STAINLESS STEEL
- FINISH :
 - CONTACT : SEE TABLE A

DRAWN	Yeh Chou	APPVL	UNIT	mm	TOLERANCE		广东科斯达电子科技有限公司 GUANG DONG KE SI DA ELECTRONIC TECHNOLOGY CO., LTD.	TITLE	防水頭12PIN (F) 端子半成品(Crimp PIN)			SHEET	1
CHK'D			SCALE	1:1	.x ±0.20 .xx ±0.10 .xxx ±0.05 .xxxx ±0.03 ANGULA ±1°			PART NO.	SEE TABLE A	DWG NO.	QC7982	VERSION	A