

CUSTOMER DWAWING

REV.	DESCRIPTION	APPVL. BY	DATE	ECN NO.
A	RELEASE	Fido Weng	05/01/09*	
B	增加TABLE A & PCB LAYOUT	Fido Weng	06/07/09*	ECN09110
C				

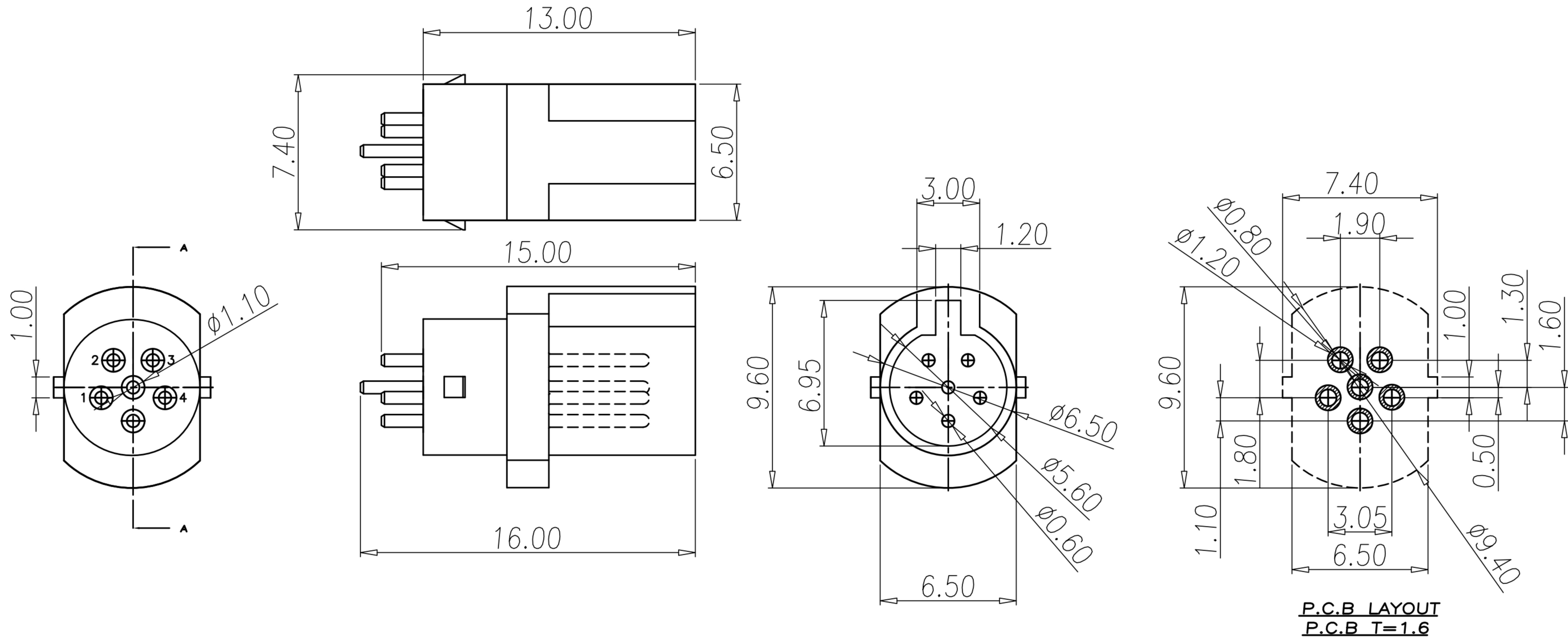

TABLE A

SPD-06M2-02	特6(M)成型式	NYLON
SPD-06M1-01	特6(M)成型式	PBT

- NOTE.
- MATERIAL :
 - 1-1. HOUSING : TABLE A ; COLOR : BLACK
 - 1-2. CONTACT : COPPER ALLOY
 - FINISH :
 - 2-1. CONTACT : 30 MICRO INCHES MIN. SILVER PLATED

DRAWN	Mark Kao	APP'D	Ku Chou	UNIT	mm	TOLERANCE		广东科斯达电子科技有限公司 GUANG DONG KE SI DA ELECTRONIC TECHNOLOGY CO., LTD.	TITLE	特6(M)成型式			SHEET	1
CHK'D	Emily Suen			SCALE	1:1	.x ±0.20 .xx ±0.10 .xxx ±0.05 .xxxx ±0.03 ANGULA ±1°			PART NO.	SEE TABLE A	DWG NO.	QC1112	VERSION	