

CUSTOMER DRAWING

REV.	DESCRIPTION	APPROVED BY	DATE	ECN NO.
A	RELEASE	Fido Weng	15/10/09'	
B	變更料帶寬度	Fido Weng	06/06/16'	
C				

步驟一:

1. 將成品一一放入包裝盤內, 依同一方向置入.
2. 包裝方式, 如圖所示.
3. 一個包裝盤內放350pcs.

步驟二:

1. 一個紙箱可以裝10個包裝盤.
2. 每盤350pcs, 每箱3.5Kpcs.
3. 將包裝盤放入防水袋中, 包裝完後再封箱.

步驟三:

1. 用膠帶將紙箱封實.
2. 將標籤貼於紙箱上.

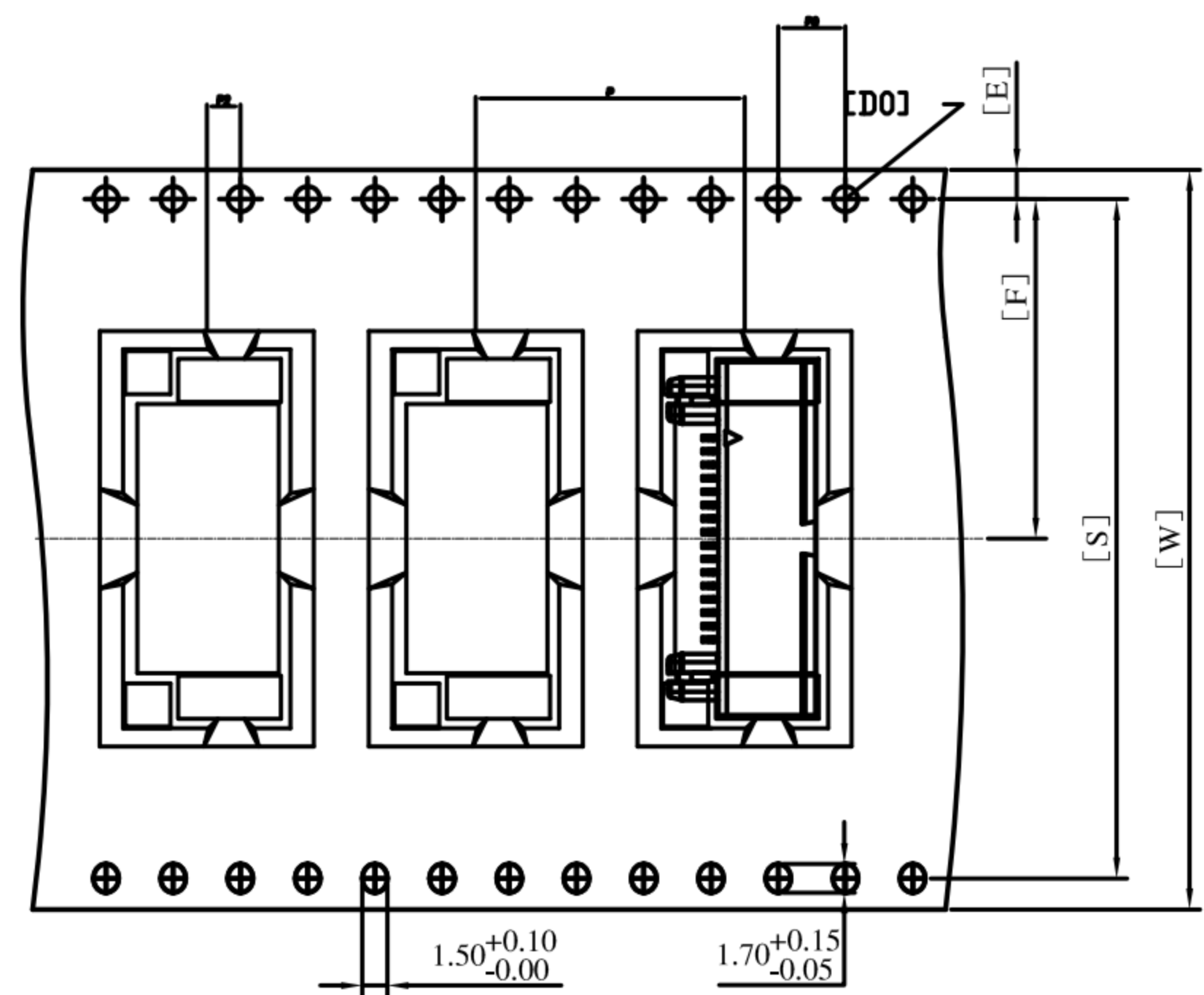
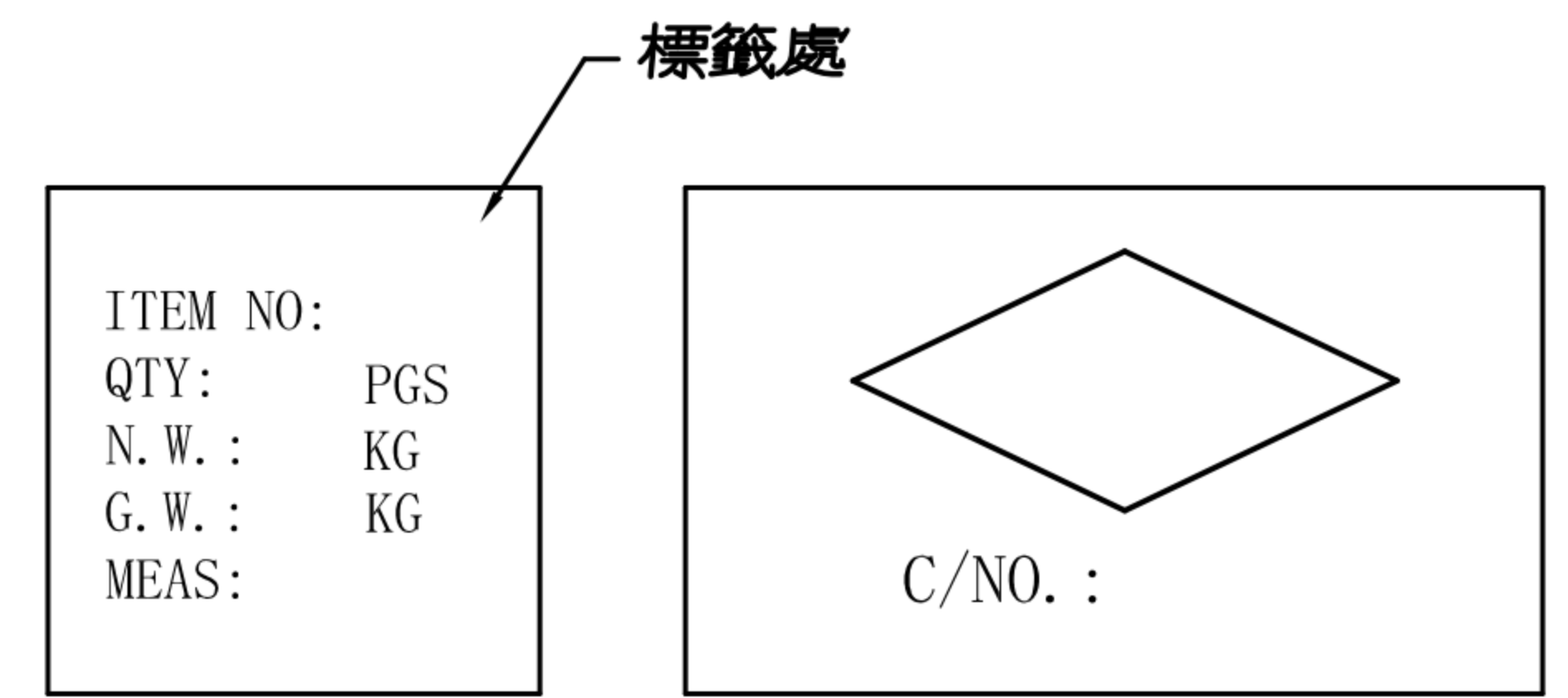
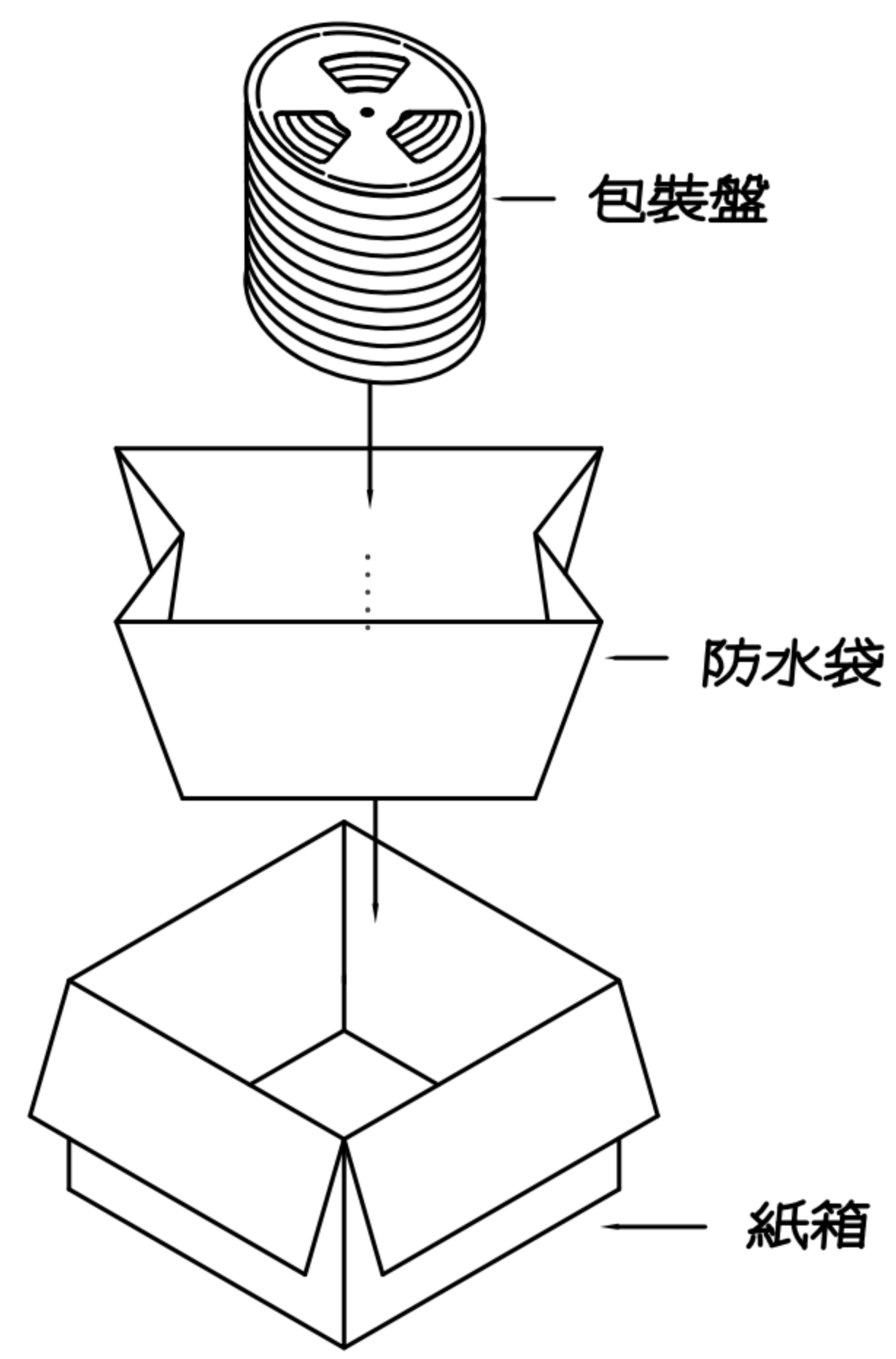
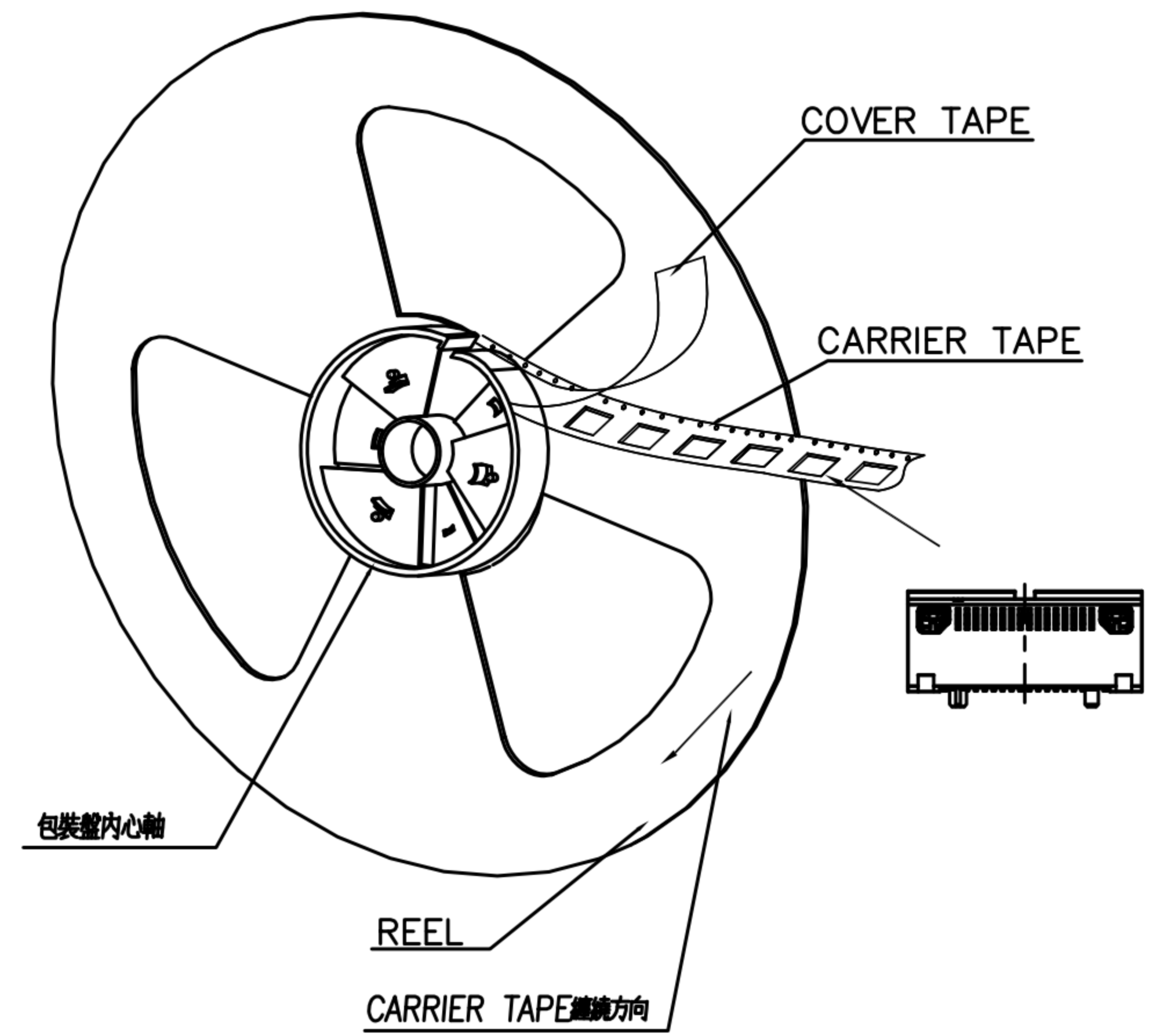

NOTE:

1. 若有未裝滿之零數箱, 必須以緩衝材塞滿.
2. 在搬運過程中要輕拿輕放.
3. 載運輸中不可堆放過多, 不可有重壓現象.
4. 在裝滿產品後, 必須空留帶前和帶後15格以上, 然後用紙膠布貼上.
5. 上帶在貼下帶時必須平整, 且黏貼處不要出現氣泡.

W	56.00 ^{+0.30} / _{-0.30}	T	0.50±0.05	P0	4.00±0.10	A0	8.40±0.10	A1
S	52.40±0.10	F	26.20±0.10	P2	2.00±0.10	B0	21.40±0.10	B1
E	1.75±0.10	P	16.00±0.10	D0	∅1.50 ± ^{0.10} / ₀	K0	11.00±0.10	K1

DRAWN	Mark Kao	APP'D	Ku Chou	UNIT	mm	TOLERANCE			TITLE	MICRO USB 5PIN(F) 直立式 SMT			SHEET	2/2
CHK'D	Emily Suen			SCALE	1:1				PART NO.	SEE TABLE A	DWG NO.	QC5130	VERSION	B

CUSTOMER DRAWING

REV.	DESCRIPTION	APPROVED BY	DATE	ECN NO.
A	RELEASE	Yeh Chou	2017/06/08	
B				
C				

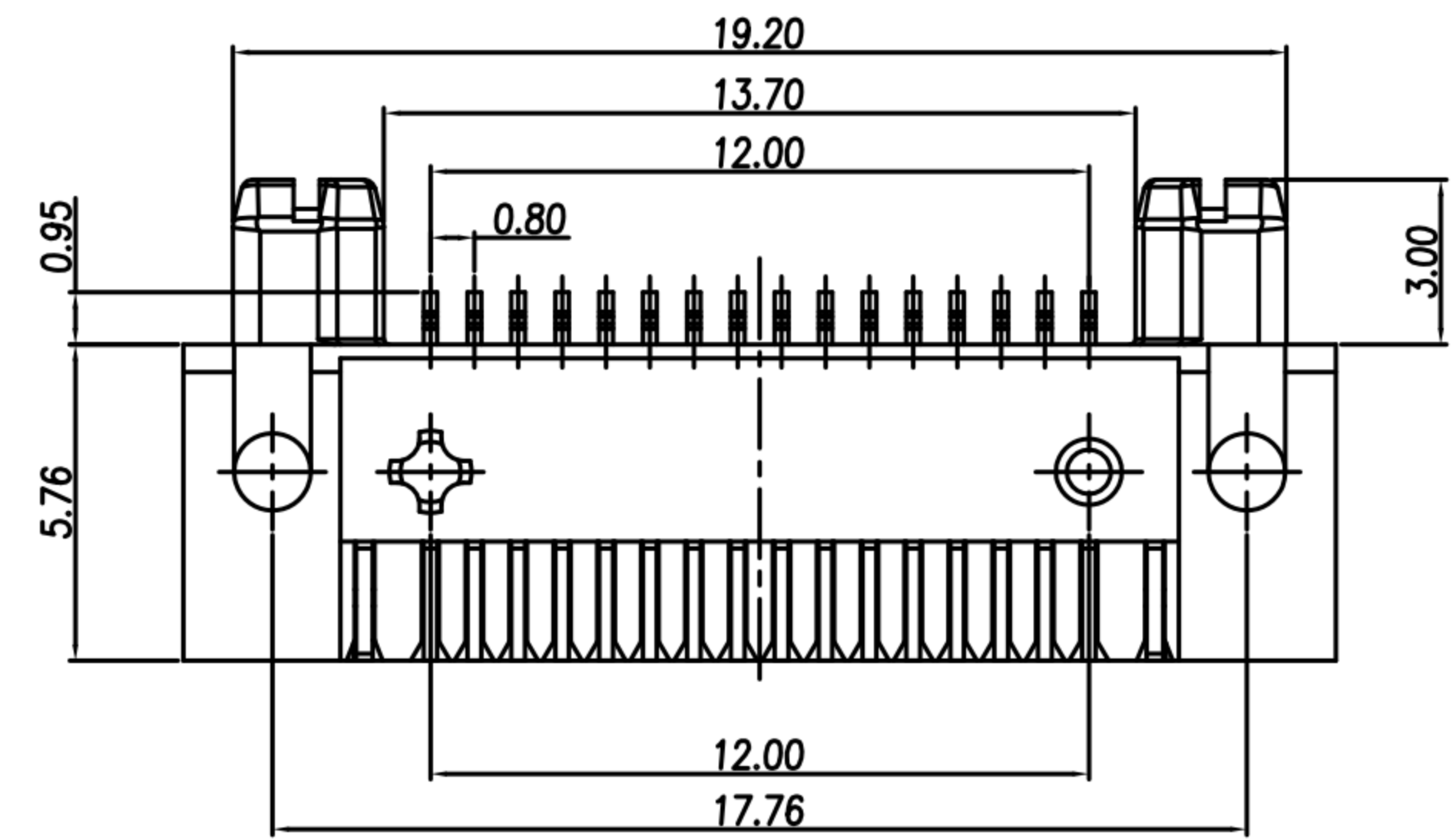
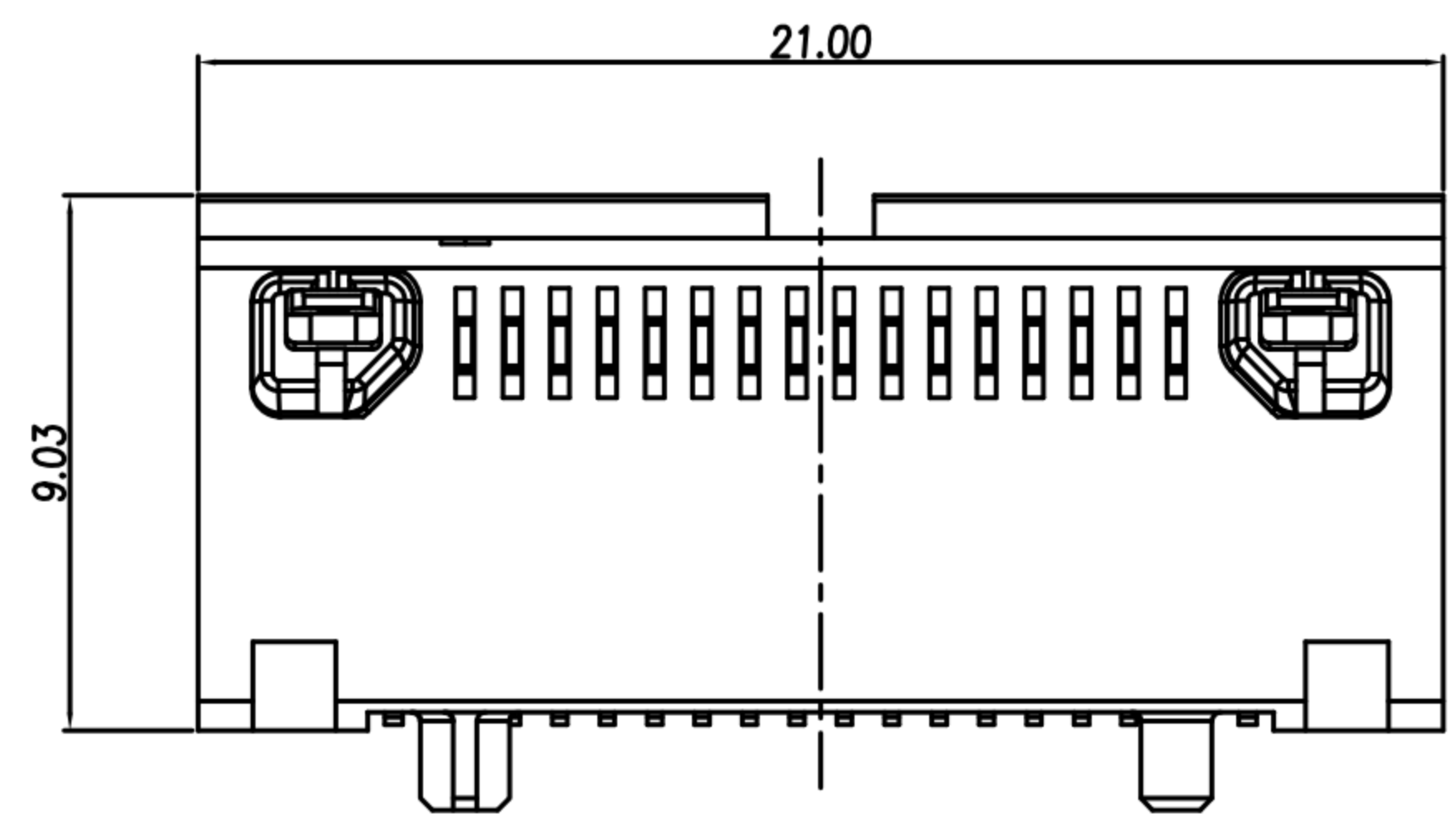
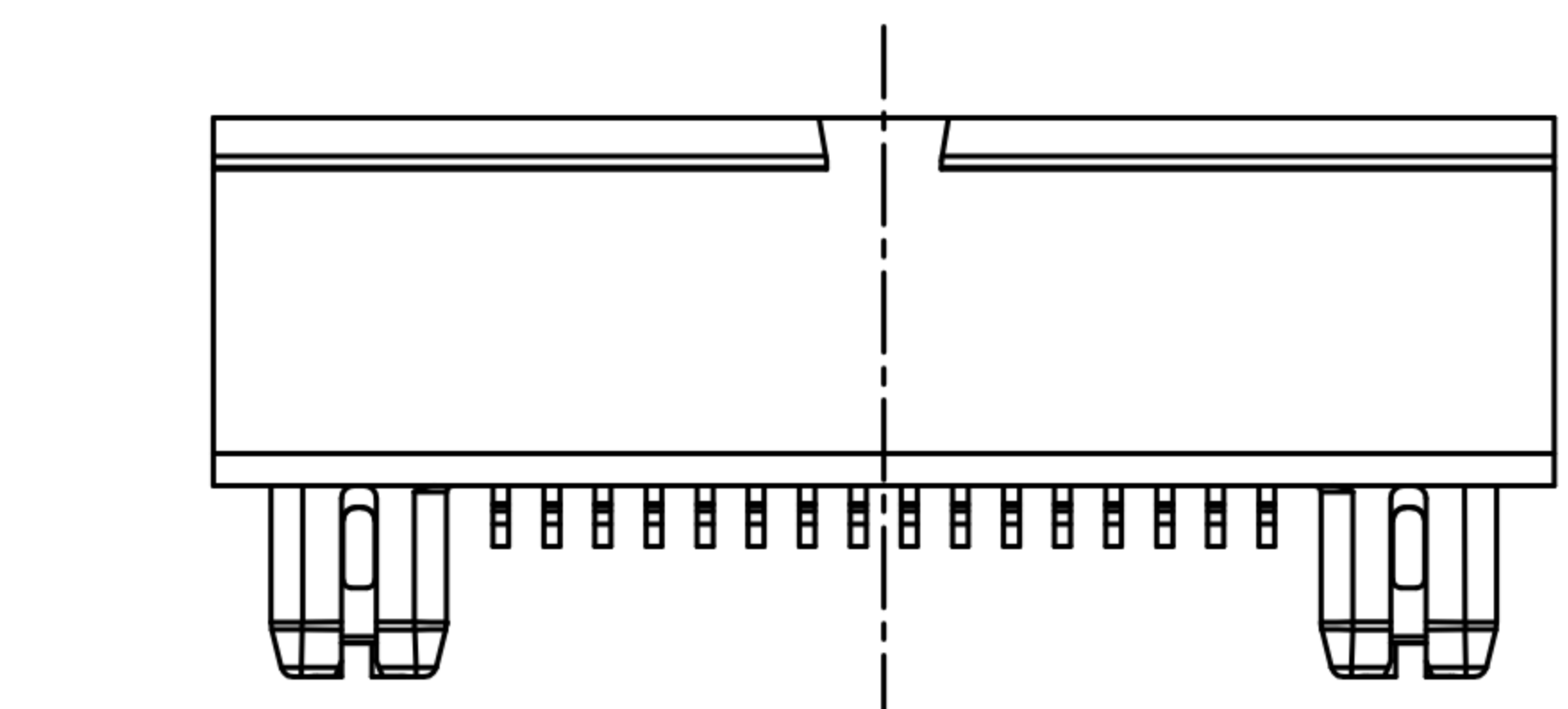

SCREW MOUNTING FEATURE

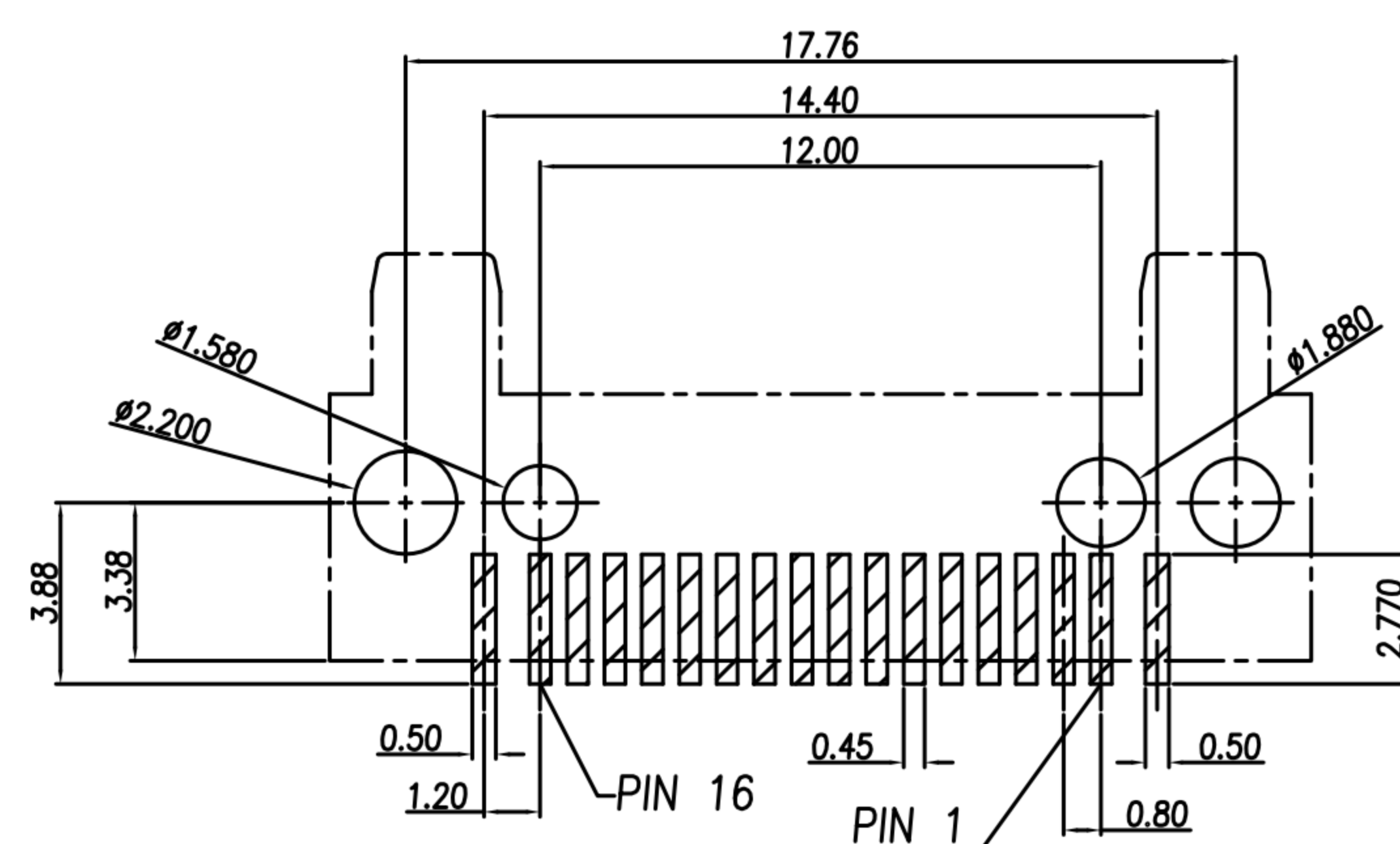
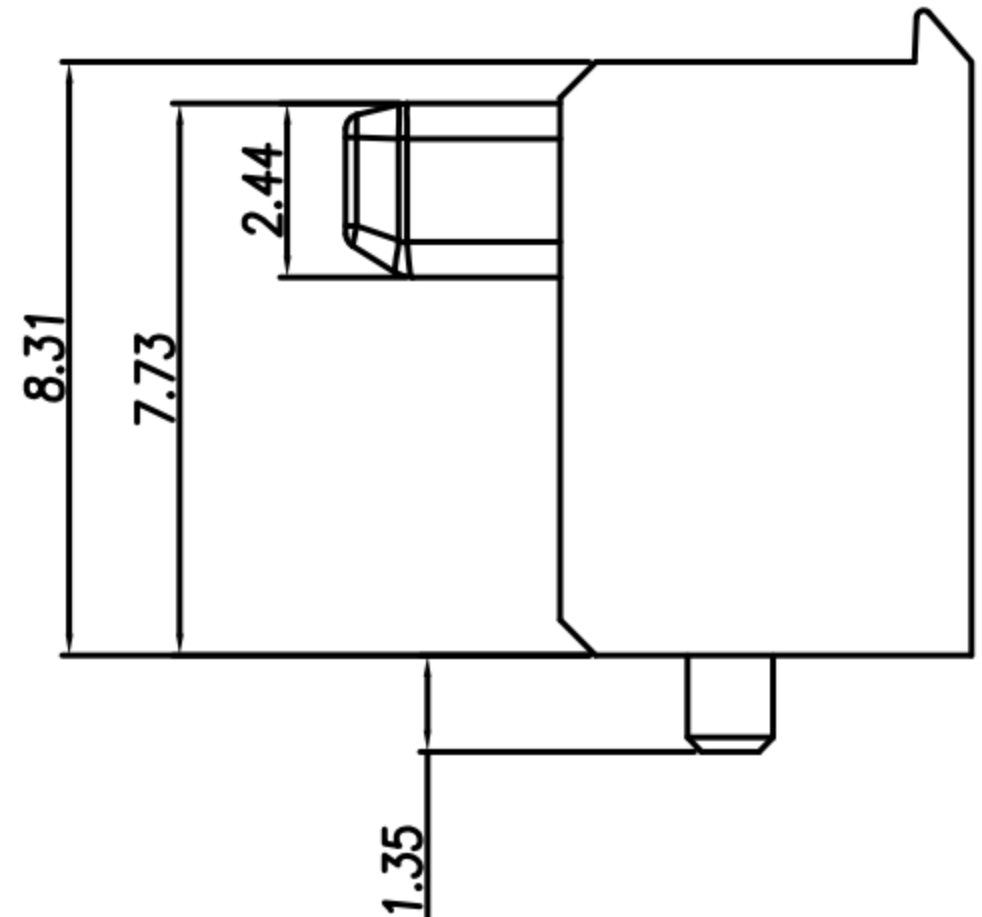

P.C.B LAYOUT

- MATERIAL :
 - 1-1. HOUSING : LCP UL94V-0 ; COLOR : BLACK
 - 1-2. CONTACT : PHOSPHOR BRONZE
 - 1-3. LATCHES FILLS : STAINLESS STEEL
- FINISH :
 - 2-1. CONTACT : CONTACT AREA : 5 MICRO INCHES MIN. GOLD PLATED
SOLDER AREA : BRIGHT TIN
UNDER PLATE : NICKEL
 - 2-2. LATCHES : BRIGHT TIN
UNDER PLATE : NICKEL

DRAWN	Mark Kao	APP'D	Ku Chou	UNIT	mm	TOLERANCE		广东科斯达电子科技有限公司 GUANG DONG KE SI DA ELECTRONIC TECHNOLOGY CO., LTD.	TITLE	HANDYLINK 16P (M) PARALLEL TO PCB			SHEET	1/2
CHK'D	Emily Suen			SCALE	1:1	.x ±0.10 .xx ±0.05 .xxx ±0.03 .xxxx ±0.01 ANGULA ±1°			PART NO.	PC-16M2-09-11	DWG NO.	QC7906	VERSION	A