

CUSTOMER DRAWING

REV.	DESCRIPTION	APPVL. BY	DATE	ECN NO.
A	RELEASE	Emily Suen	09/03/12	
B				
C				

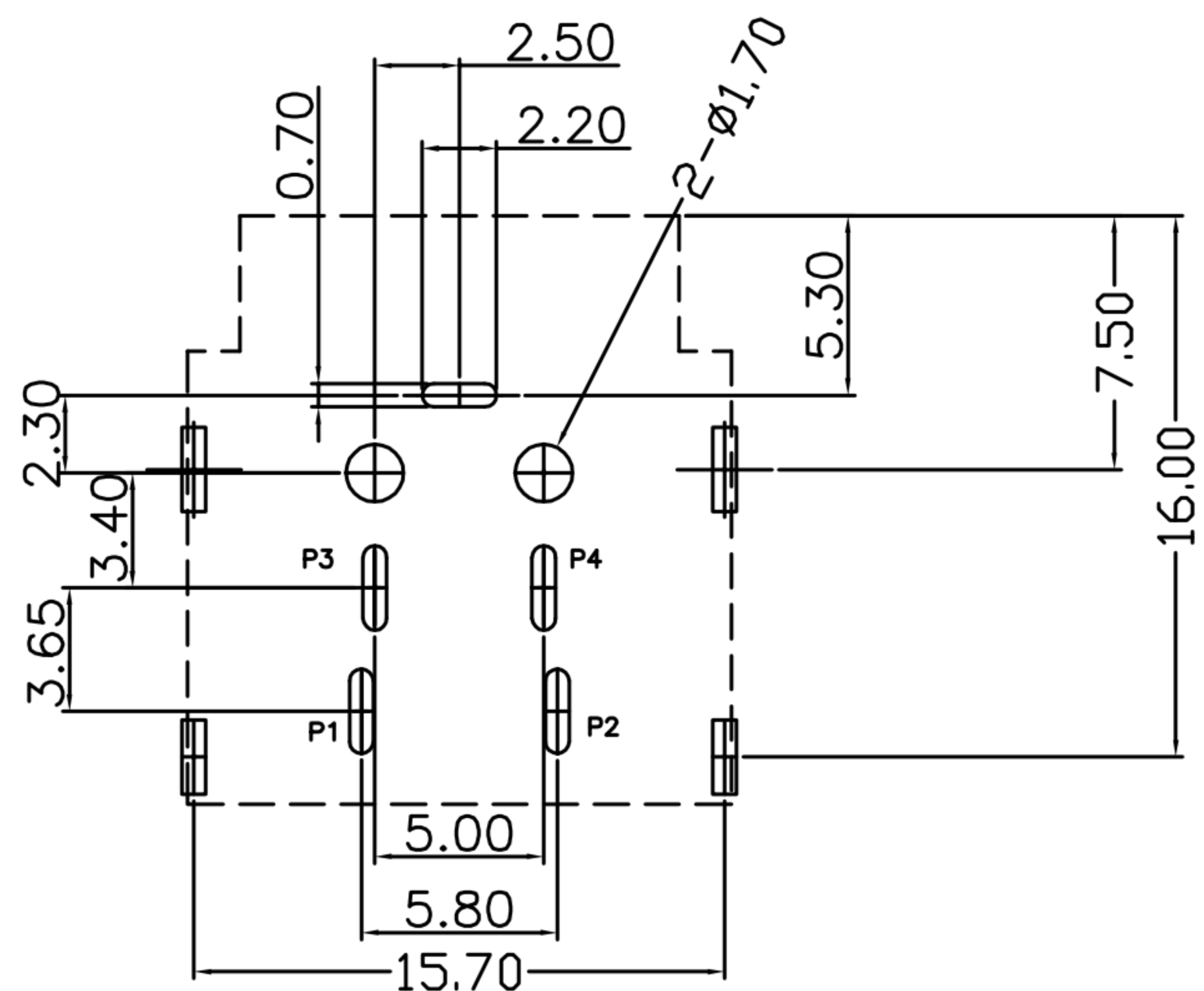
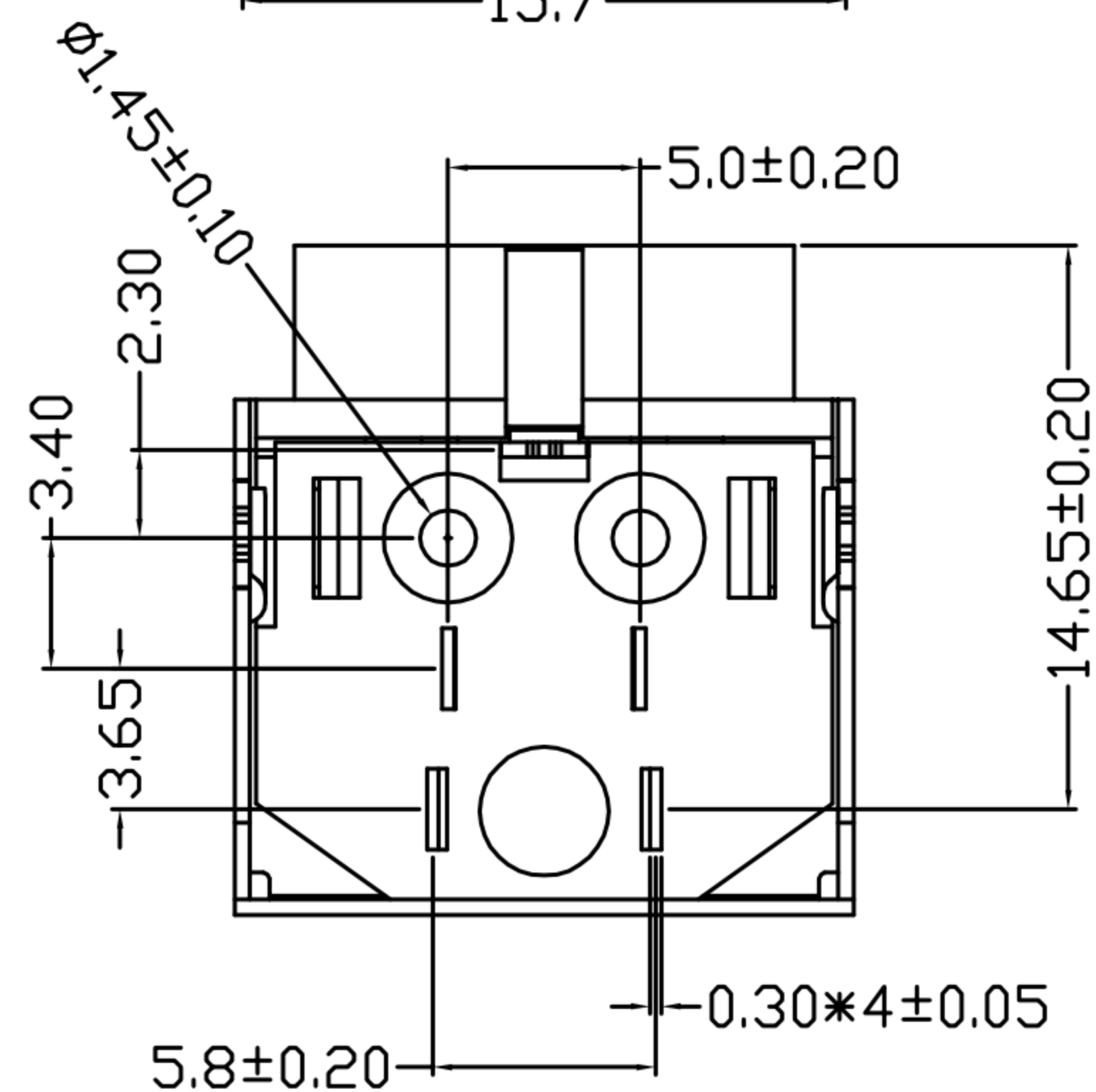
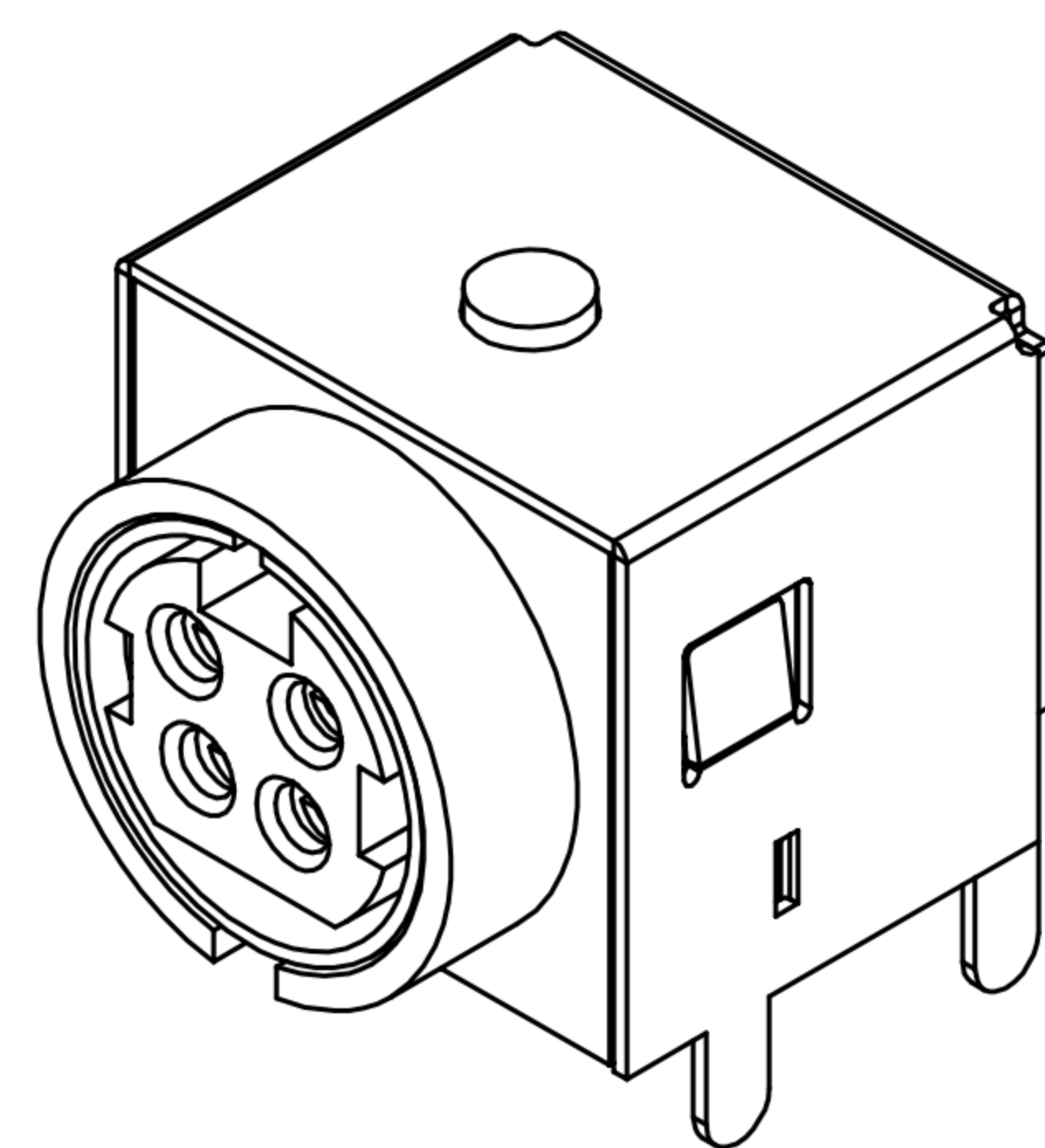
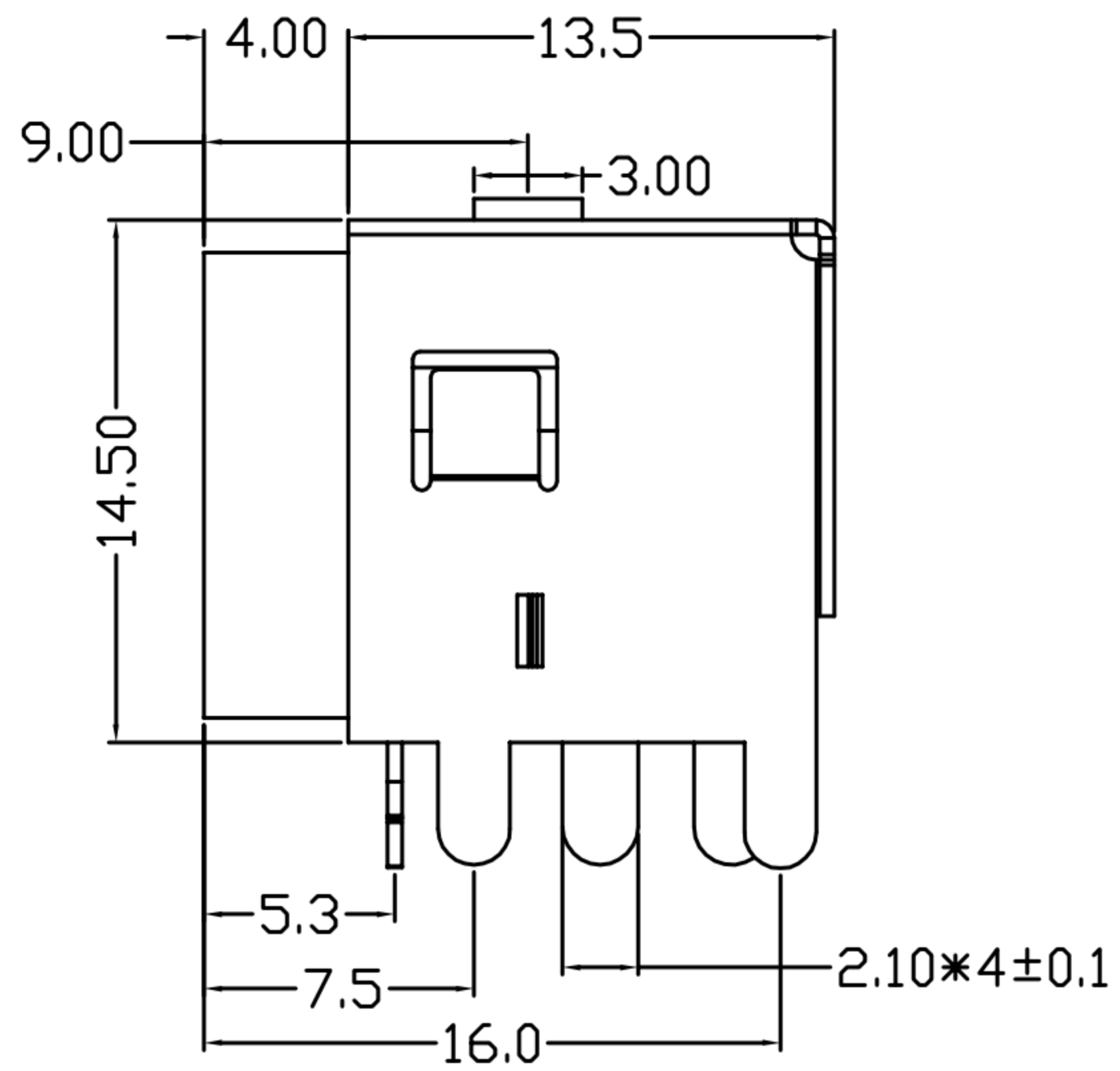
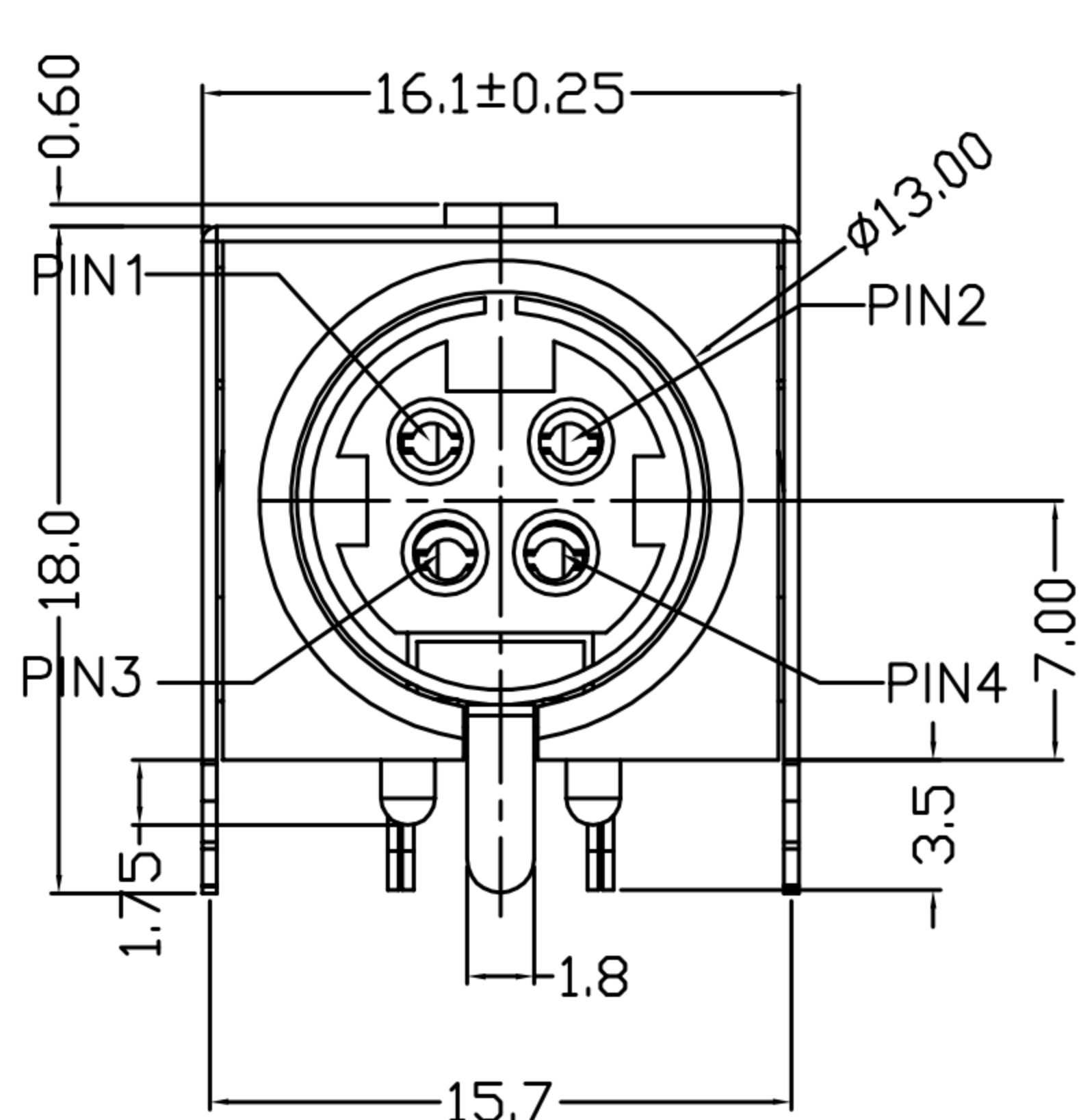

- MATERIAL :
 - 1-1. HOUSING : PBT
 - 1-2. CONTACT : PHOSPHOR BRONZE
 - 1-3. GROUND : BRASS
 - 1-4. SHELL : SPCC
- FINISH :
 - 2-1. CONTACT : SILVER PLATING
 - 2-2. GROUND : NICKEL PLATED OVER ALL
 - 2-3. SHELL : TIN PLATED OVER ALL
- ELECTRICAL SPECIFICATION :
 - 3-1. RATED CURRENT FOR 3P : PIN1&2 7.5A
PIN3 1A
RATED CURRENT FOR 4P : 7.5A FOR ALL PIN
 - 3-2. RATED VOLTAGE : 20V DC
 - 3-3. CONTACT RESISTANCE : 30mΩ
 - 3-4. INSULATION RESISTANCE : 50MΩ Min. at 250V DC
 - 3-5. DIELECTRIC STRENGTH : 250V AC / 1 minute
 - 3-6. INSERTION FORCE : 45N max.
 - 3-7. WITHDRAWAL FORCE : 9N TO 30N
 - 3-8. DURABILITY TEST : 1000 Cycles
- ENVIRONMENTAL :
 - 4-1. OPERATION TEMPERATURE : -20 °C~85°C

Recommend P.C.B Layout
(BOTTOM VIEW)

DRAW	Mark Kao	APPVL	Ku Chou	UNIT	mm	TOLERANCE		广东科斯达电子科技有限公司 GUANG DONG KE SI DA ELECTRONIC TECHNOLOGY CO., LTD.	TITLE	PowerDin 4(F) 板端圆形DIP加鐵殼 (PBT)			SHEET	1/2
CHECK	Emily Suen			SCALE	1:1	.x ±0.20 .xx ±0.10 .xxx ±0.05 .xxxx ±0.01 ANGULA ±1°			PART NO.	PD-04F3-03-01	DWG NO.	QC9489	VERSION	A