

# CUSTOMER DRAWING

REV.	DESCRIPTION	APPROVED BY	DATE	ECN NO.
A	RELEASE	Yeh Chou	2017/08/18	
B				
C				

- MATERIAL :
  - 1-1. HOUSING : PA46 UL94V-0 ; COLOR : BLACK
  - 1-2. CONTACT : BERYLLIUM COPPER
  - 1-3. LATCH SOLDERTAILS : STAINLESS STEEL.
- FINISH :
  - 2-1. CONTACT : CONTACT AREA : 5 MICRO INCHES MIN. GOLD PLATED  
SOLDER AREA : BRIGHT TIN  
UNDER PLATE : NICKEL
  - 2-2. LATCH SOLDERTAILS : BRIGHT TIN  
UNDER PLATE : NICKEL
- ELECTRICAL SPECIFICATION :
  - 3-1. Rated current : 1.5A
  - 3-2. Rated Voltage : 30V
- Environmental :
  - 4-1. Operation Temperature : -40℃~80℃

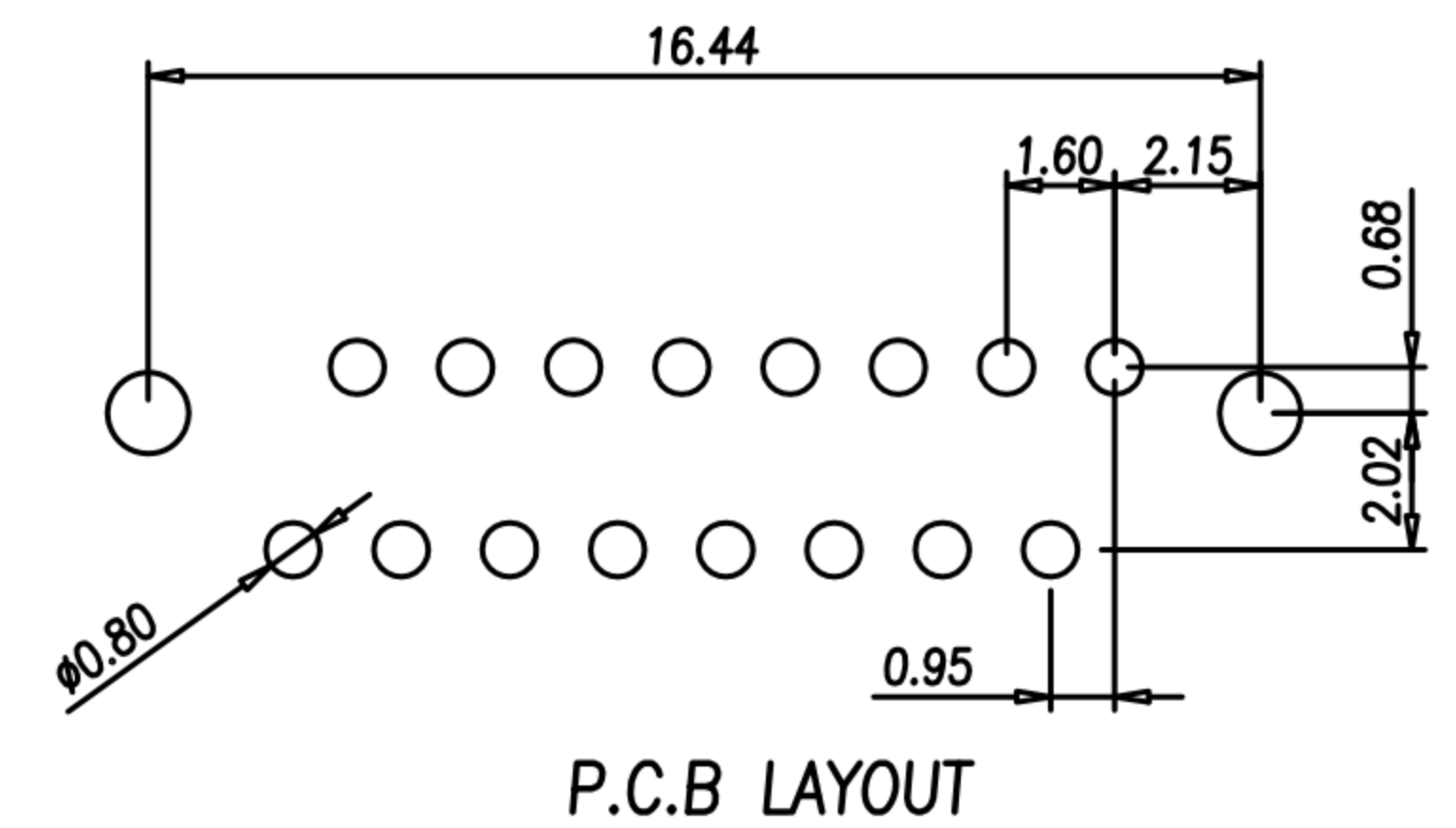
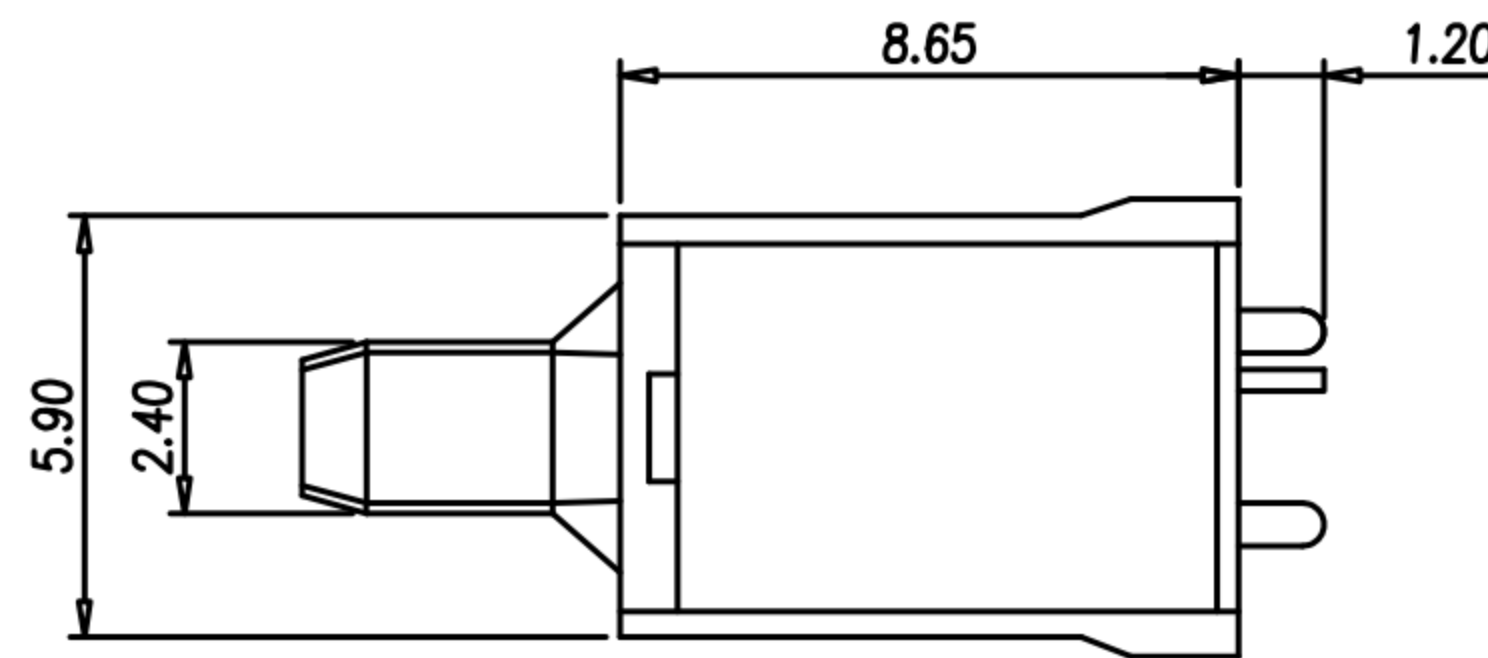
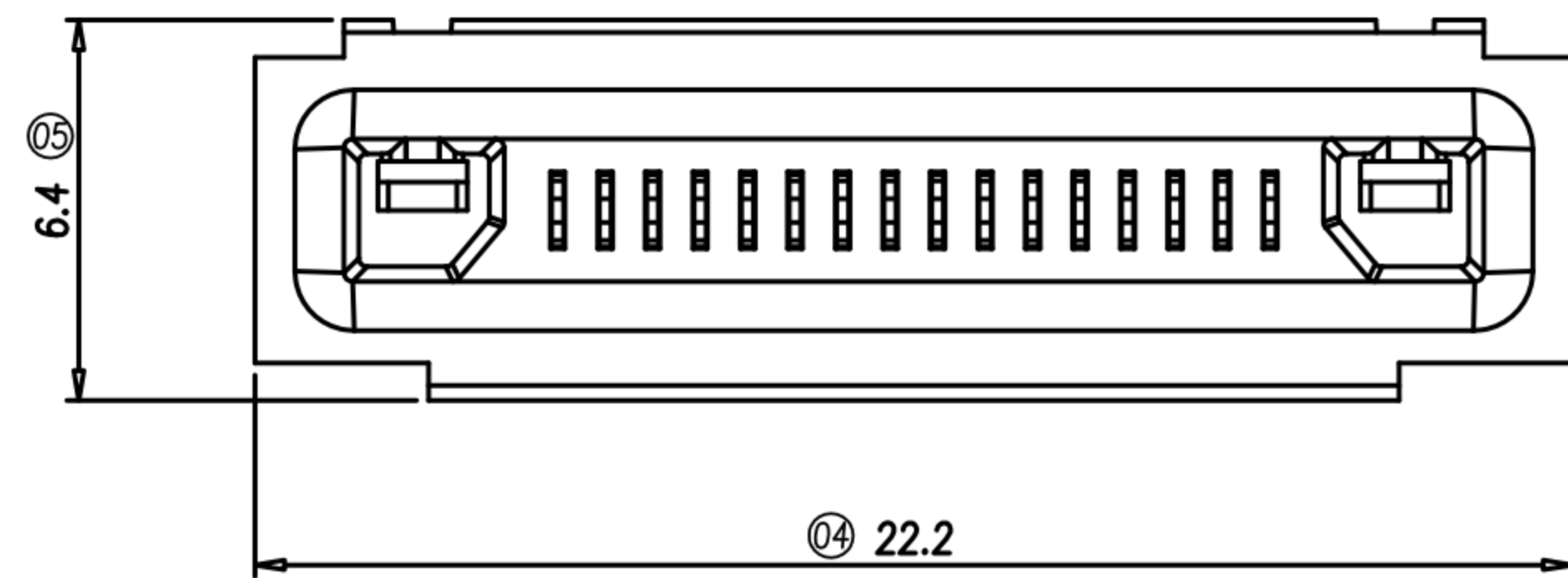
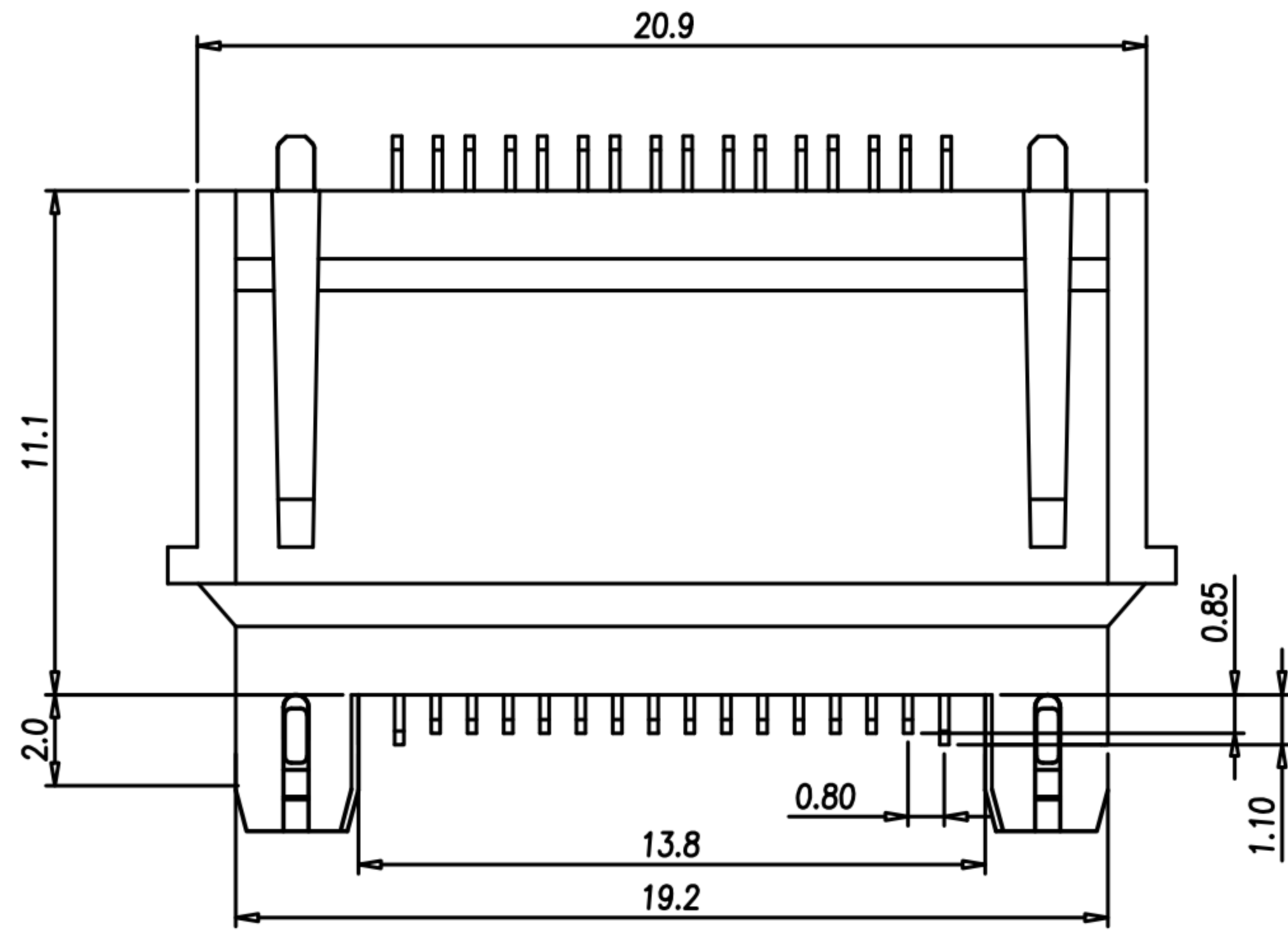

DRAWN	Mark Kao	APP'D	Ku Chou	UNIT	mm	TOLERANCE		广东科斯达电子科技有限公司 GUANG DONG KE SI DA ELECTRONIC TECHNOLOGY CO., LTD.	TITLE	HANDYLINK 16P (M) PLUG TO PCB TERMINATION			SHEET	
CHK'D	Emily Suen			SCALE	1:1	.x ±0.10 .xx ±0.05 .xxx ±0.03 .xxx ±0.01 ANGULA ±1°			PART NO.	PC-16M2-10-10	DWG NO.	QC7925	VERSION	