

CUSTOMER DRAWING

REV.	DESCRIPTION	APPROVED BY	DATE	ECN NO.
△A				
△B	圖面整合	Ku Chou	2018/01/03	
△C				

包裝說明:

1. 如圖所示,將成品按規定之包裝數量置入盤子中,並在盤上貼上盤面標籤一張
2. 10盒盤子一個單位以模帶封住,在裝入箱內,再封膠帶
3. 紙箱封蓋後以封箱帶封箱,並在側面貼上出貨標籤和ROHS標籤
4. 標籤:若有客戶另有貼標籤要求,則按其訂單注明之要求貼
5. 紙箱尺寸及印刷包材圖面(總重量僅供參考,以實際出貨為準)
6. 未滿之零數箱,需以緩衝材料填滿
7. 在搬運過程中要輕拿輕放.
8. 載運輸中不可堆放過多,不可有重壓現象.
8. 紙箱:SEE TABLE A
9. 一盤:100PCS
10. 一箱:2600PCS

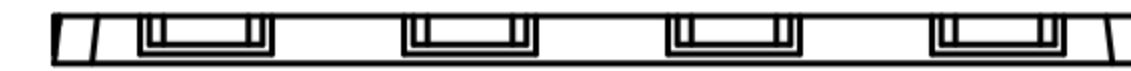
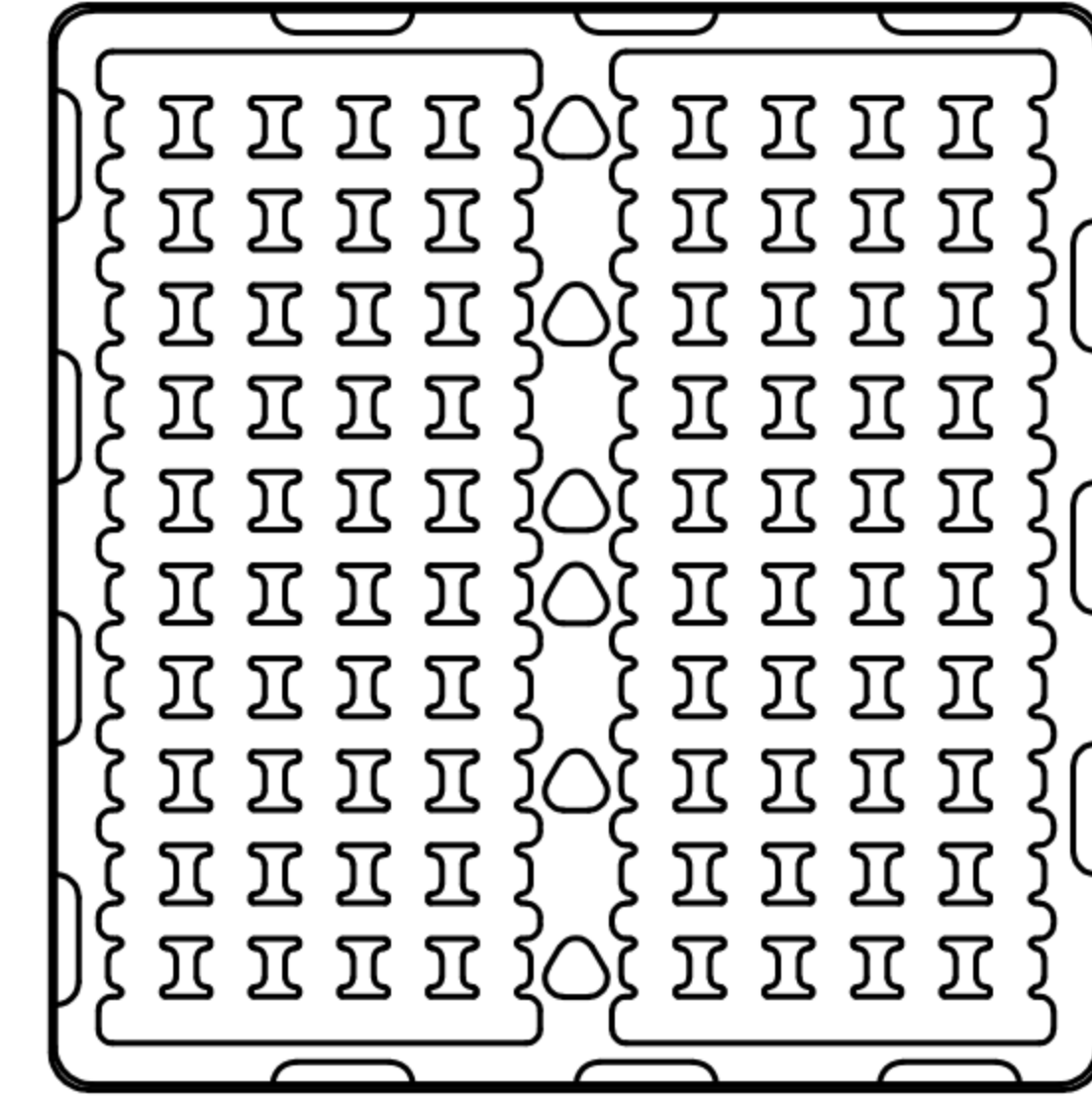
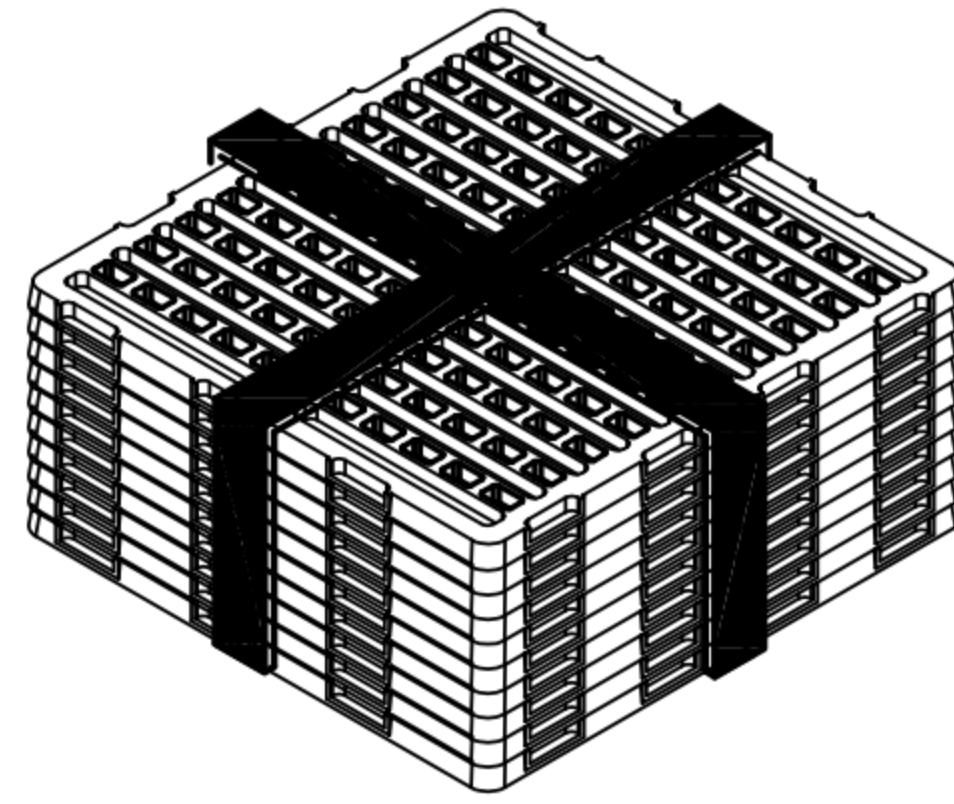
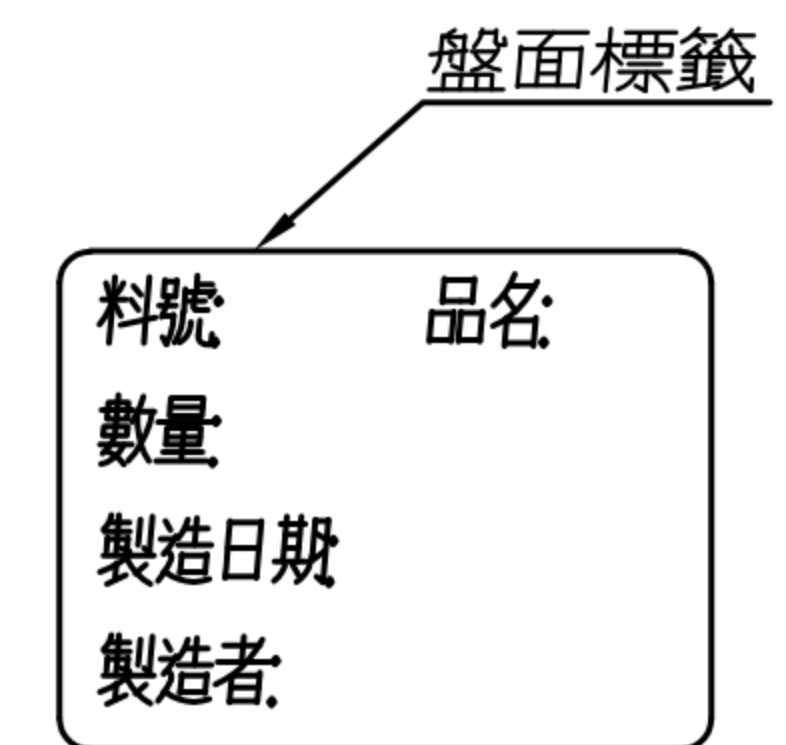
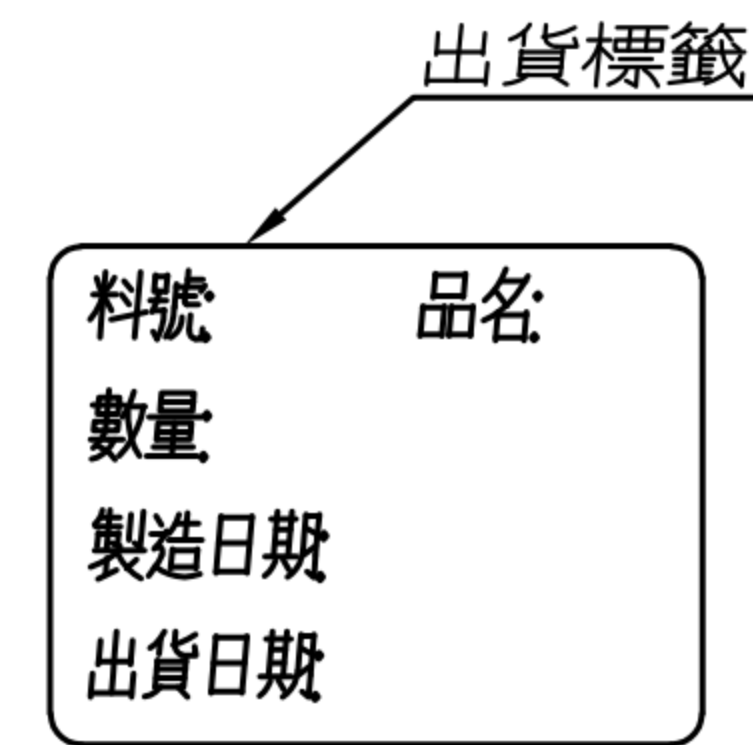
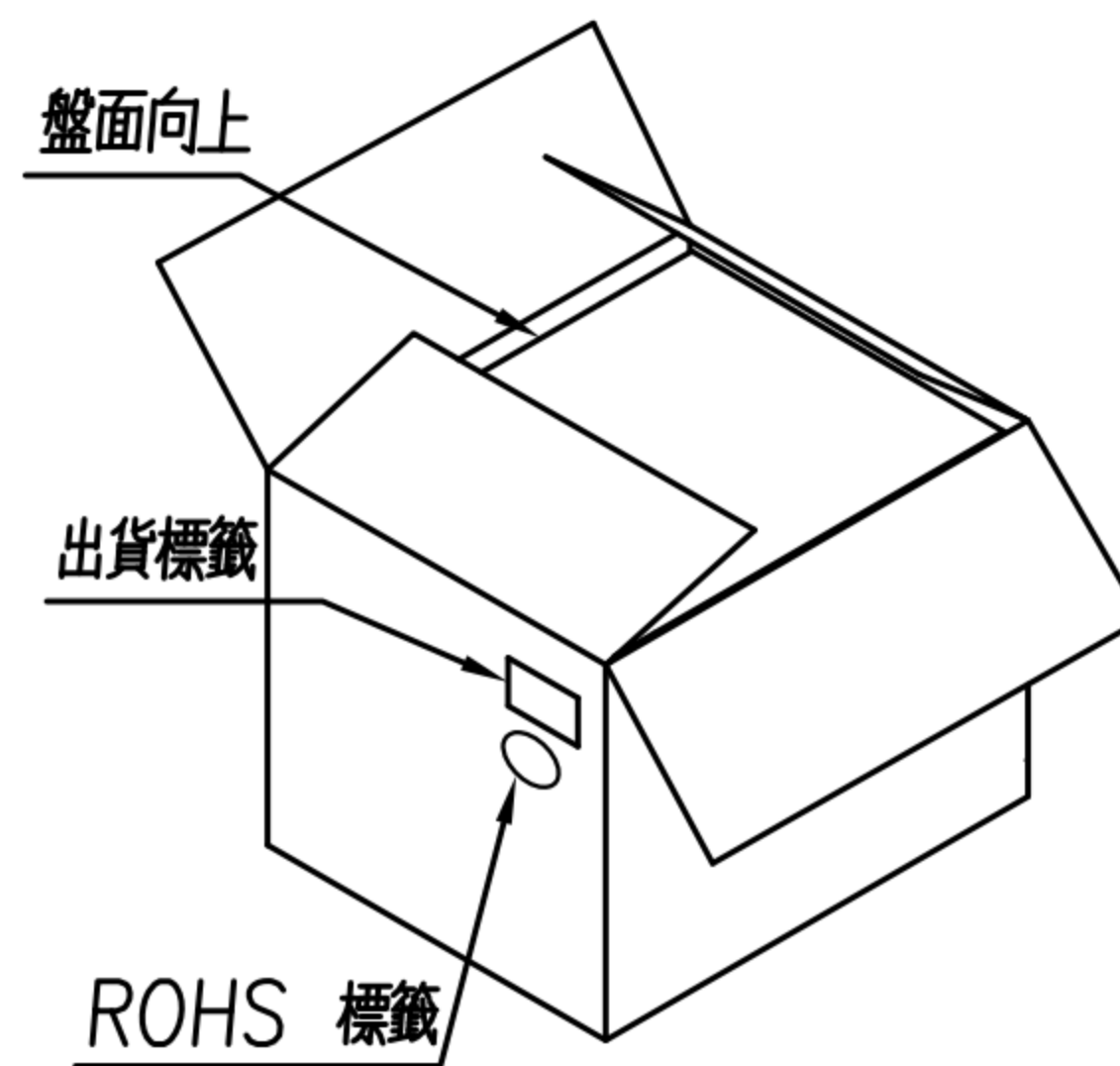
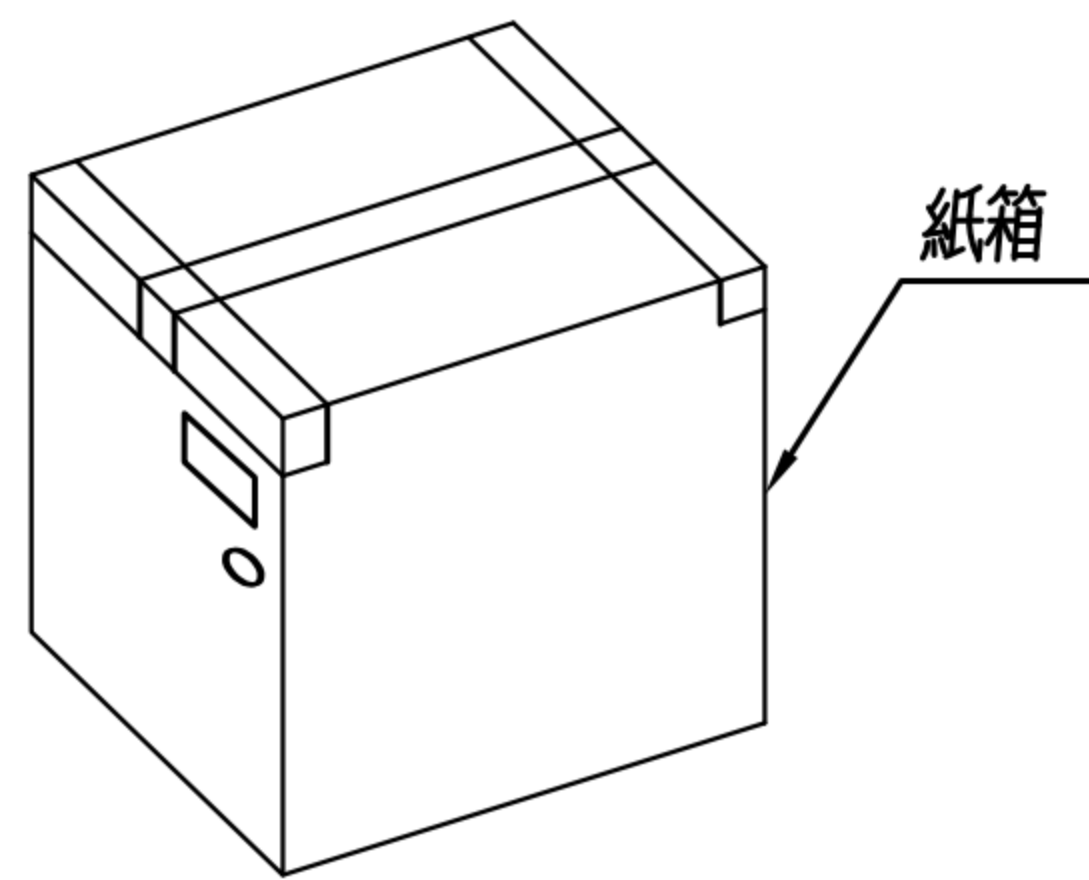

TABLE A

	PK-BOX002	F-008(1.02才紙箱)	L=415mm,W=297mm,H=242mm
✓	PK-BOX003	F-009(0.4才紙箱)	L=373mm,W=233mm,H=133mm
	PK-BOX004	F-010(0.7才紙箱)	L=333mm,W=236mm,H=221mm
	PK-BOX018	硬紙箱0.4才	L=373mm,W=233mm,H=133mm
	PK-BOX019	紙箱1.06才(全不印字)	L=321mm,W=267mm,H=345mm
	P/N	包材名稱	備註



DRAWN	Emily Suen	APP'D	Ku Chou	UNIT	mm	TOLERANCE			TITLE	TABLE A			SHEET
CHK'D	Emily Suen			SCALE	1:1	.x ±0.20 .xx ±0.10 .xxx ±0.05 .xxxx ±0.03 ANGULA ±1°			PART NO.	TABLE A	DWG NO.	QC0699	VERSION B

CUSTOMER DRAWING

REV.	DESCRIPTION	APPROVED BY	DATE	ECN NO.
A				
B	圖面整合	Ku Chou	2018/01/03	
C				

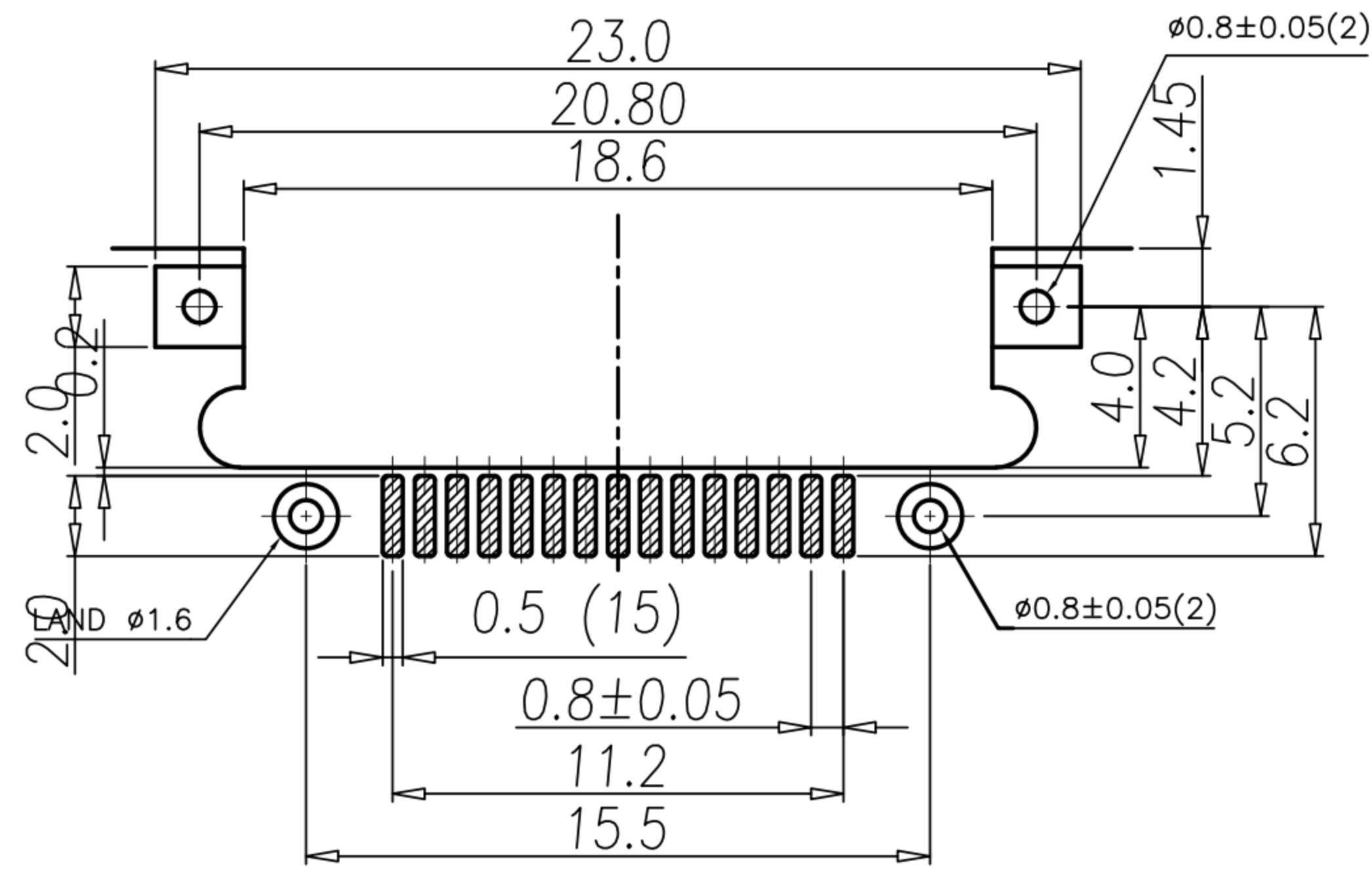

P.C.B LAYOUT
TOP VIEW
TOLERANCES:±0.1

- MATERIAL :
 - 1-1. HOUSING : LCP UL94V-0 ; COLOR : BLACK
 - 1-2. CONTACT : PHOSPHOR BRONZE
 - 1-3. SHELL : STAINLESS STEEL
- FINISH :
 - 2-1. CONTACT : 5u" MIN. GOLD PLATED
UNDER PLATE : NICKEL
 - 2-2. SHELL : NICKEL PLATED 60u" ~ 100u" OVER ALL
- ELECTRICAL SPECIFICATION :
 - 3-1. Rated current : 0.5A
 - 3-2. Voltage :125V
- Environmental :
 - 4-1. Operation Temperature : -40℃~105℃

B Type	A Type
B1 Type	A1 Type
B2 Type	A2 Type
B3 Type	A3 Type

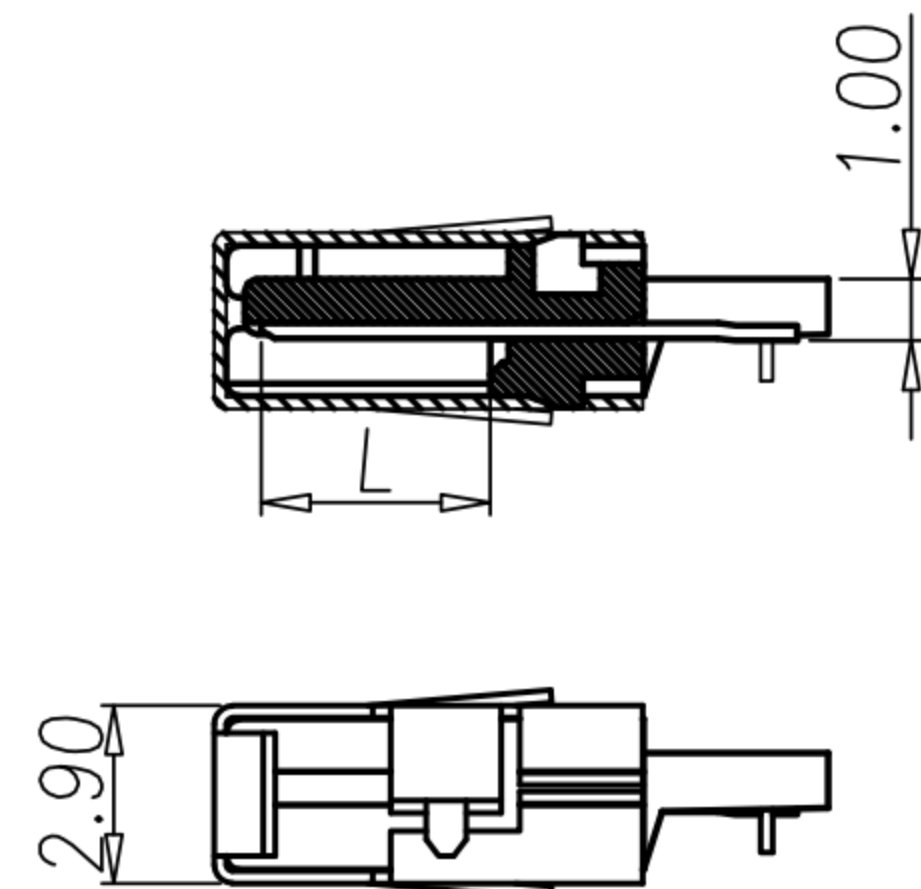
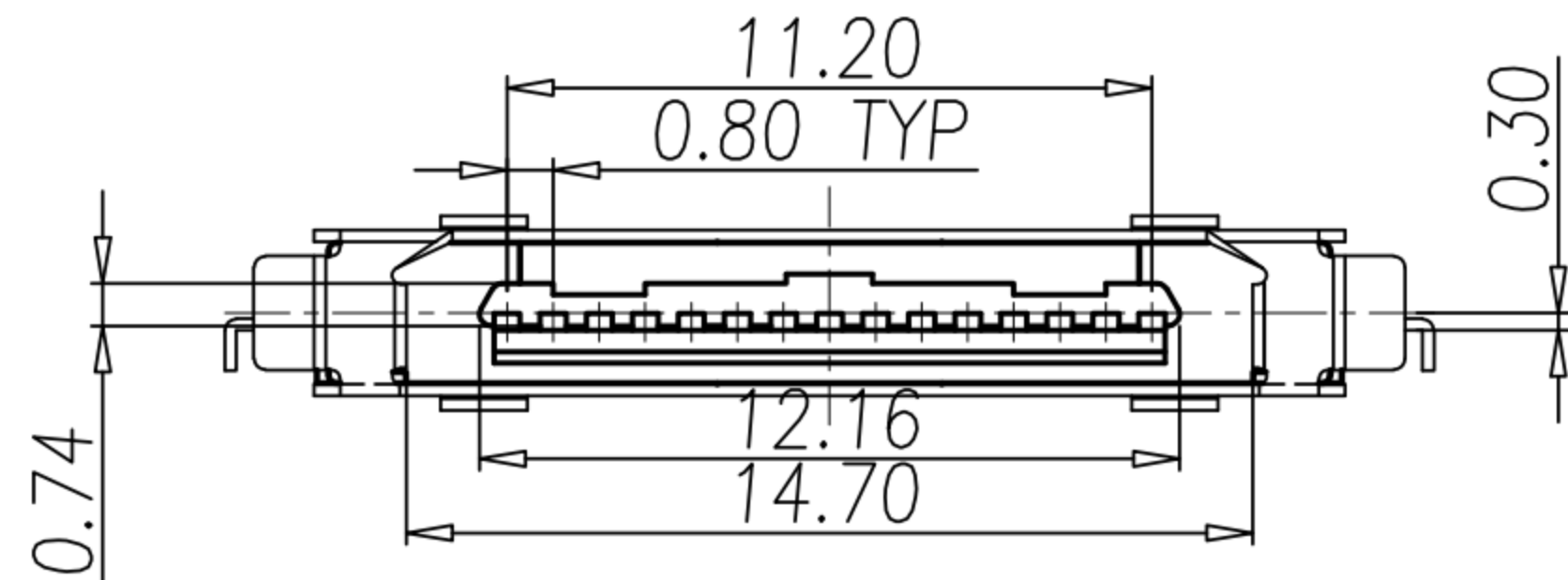
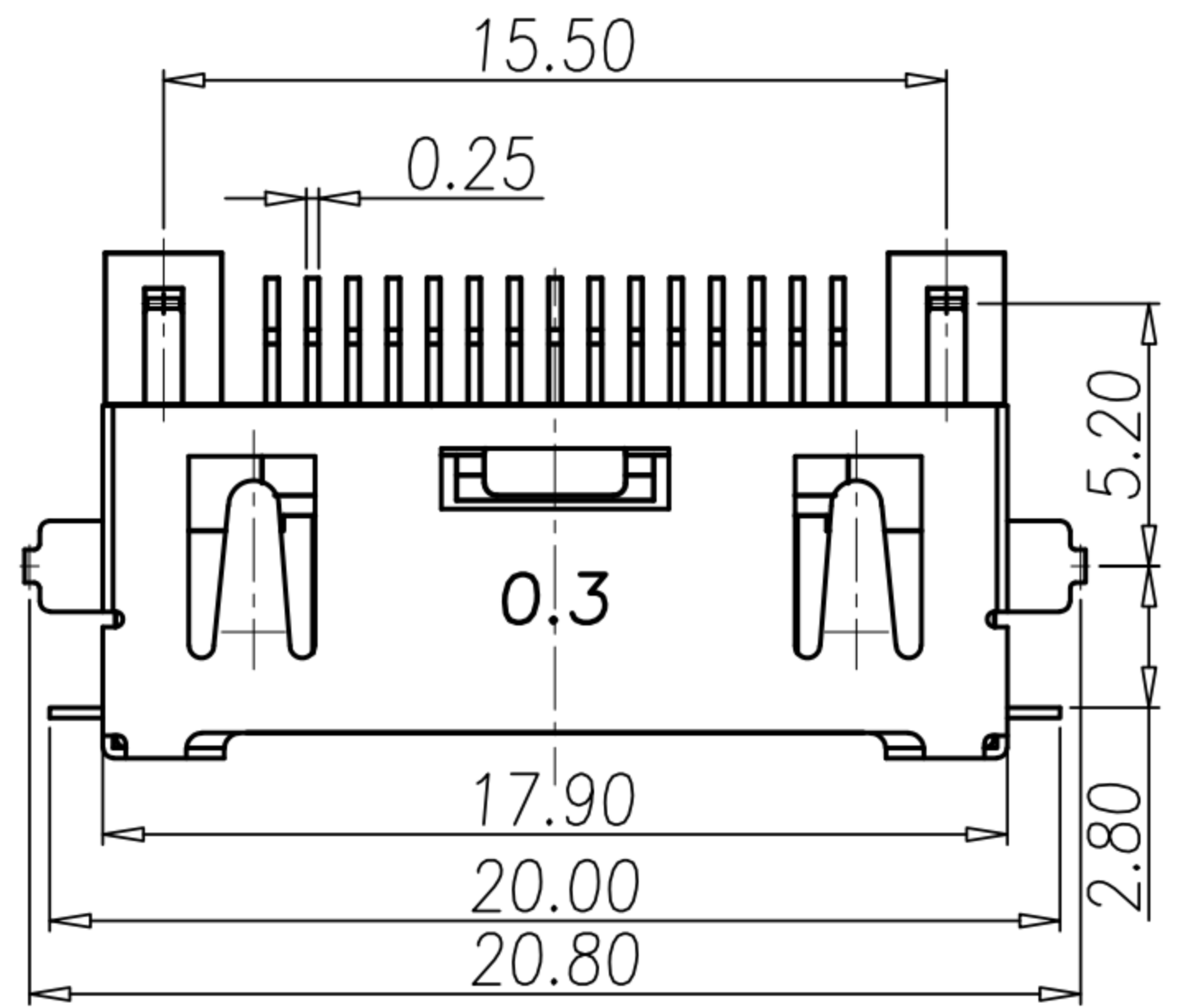

CONTACT POS.	L
P1&P15	3.7
OTHERS	3.0

TABLE A

	P/N	DESCRIPTION
1	PC-15F4-01	PCMCIA 15P (F) 0.3 A TYPE
2	PC-15F4-09	PCMCIA 15P (F) 0.3 A1 TYPE
3	PC-15F4-04	PCMCIA 15P (F) 0.3 A2 TYPE
4	PC-15F4-05	PCMCIA 15P (F) 0.3 A3 TYPE
5	PC-15F4-03	PCMCIA 15P (F) 0.3 B TYPE
6	PC-15F4-08	PCMCIA 15P (F) 0.3 B1 TYPE
7	PC-15F4-17	PCMCIA 15P (F) 0.3 B2 TYPE
8	PC-15F4-02	PCMCIA 15P (F) 0.3 B3 TYPE