

CUSTOMER DRAWING

REV.	DESCRIPTION	APPROVED BY	DATE	ECN NO.
F	RELEASE	Fido Weng	22/12/08'	
G				
H				

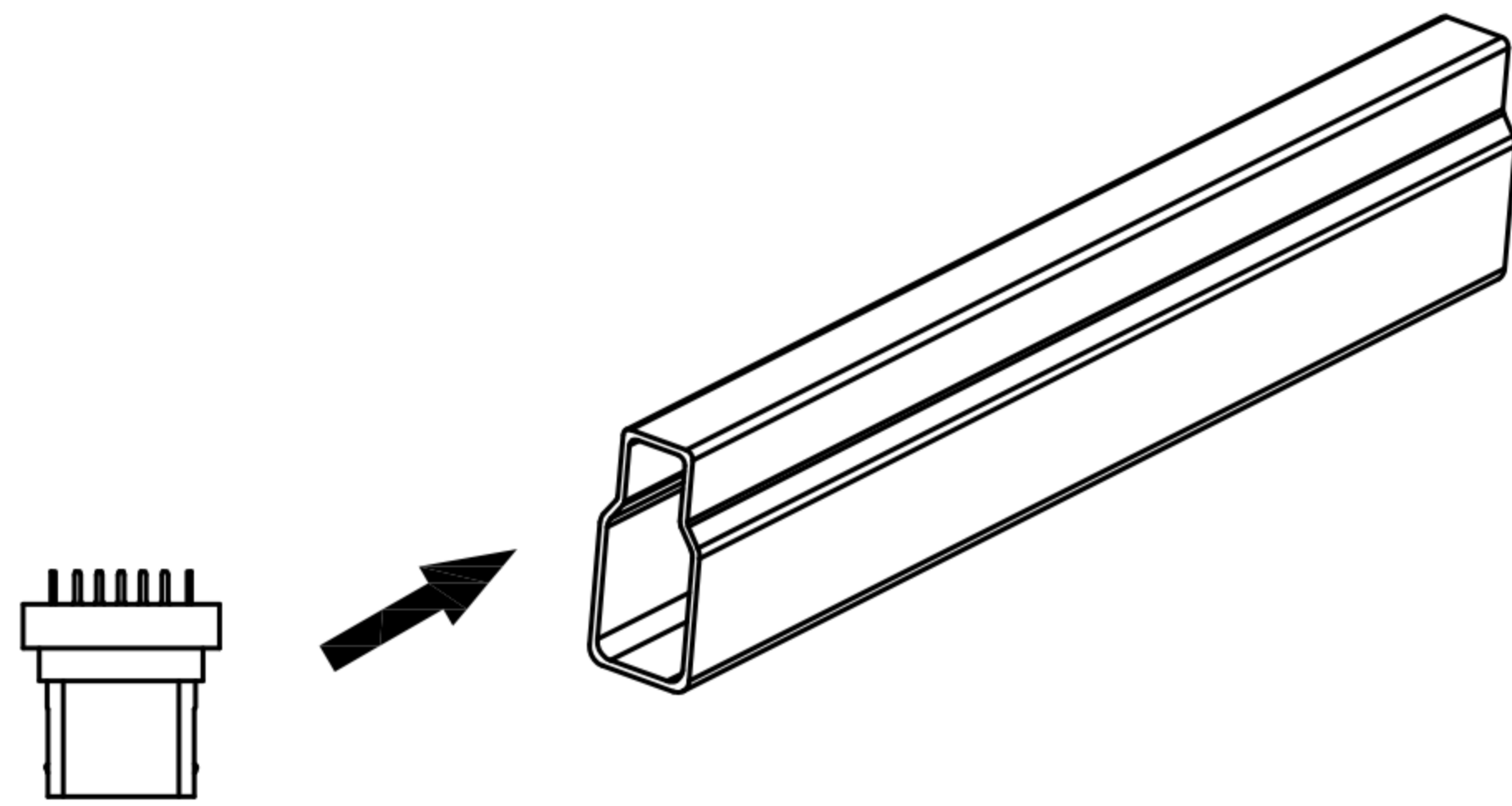

PUT MU-10M1-0X THE CONNECTOR IN THE TUBE
38PCS/1TUBE

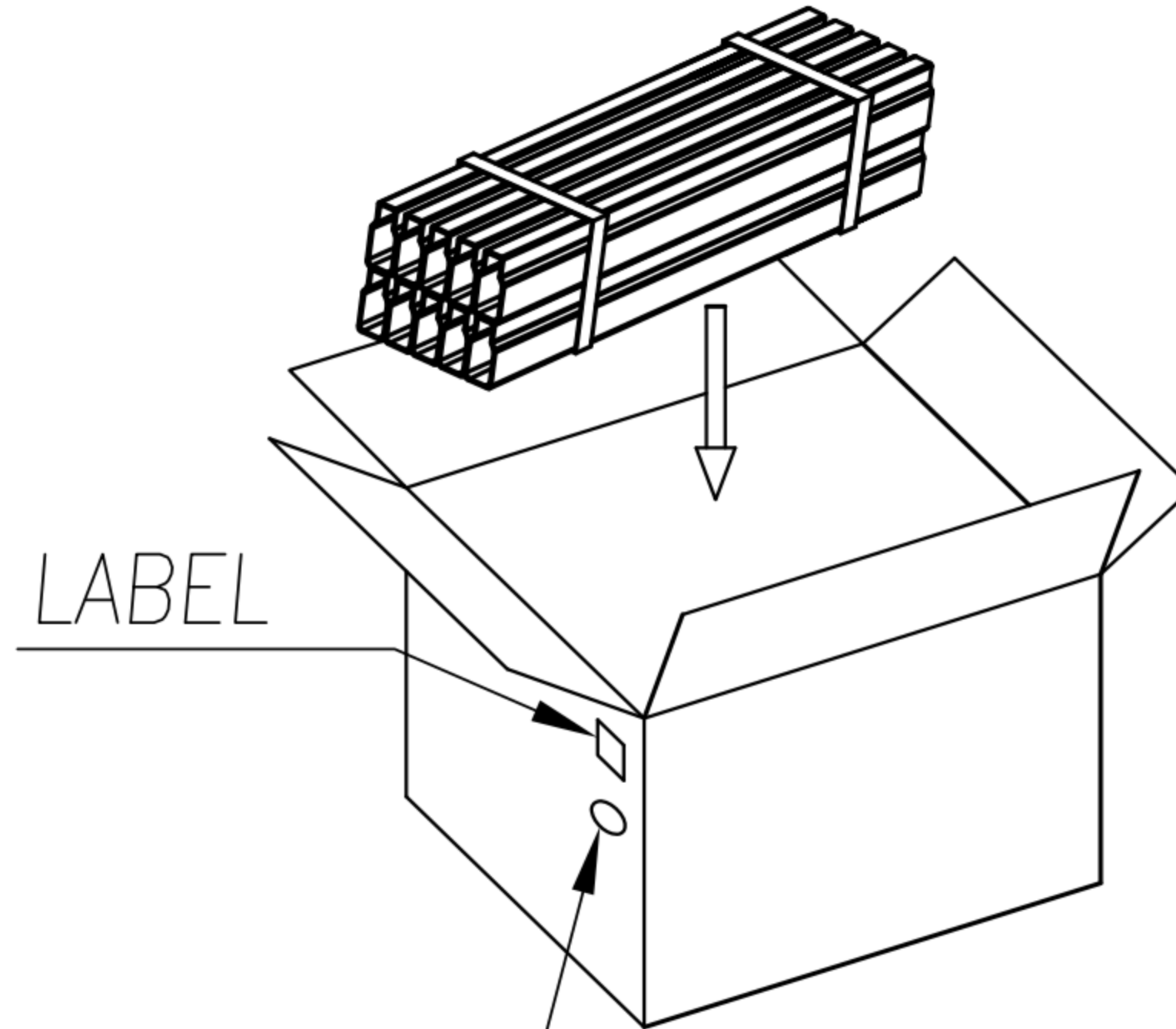

RoHS LABEL

PUT STACK TUBES INTO THE CARTON BOXES

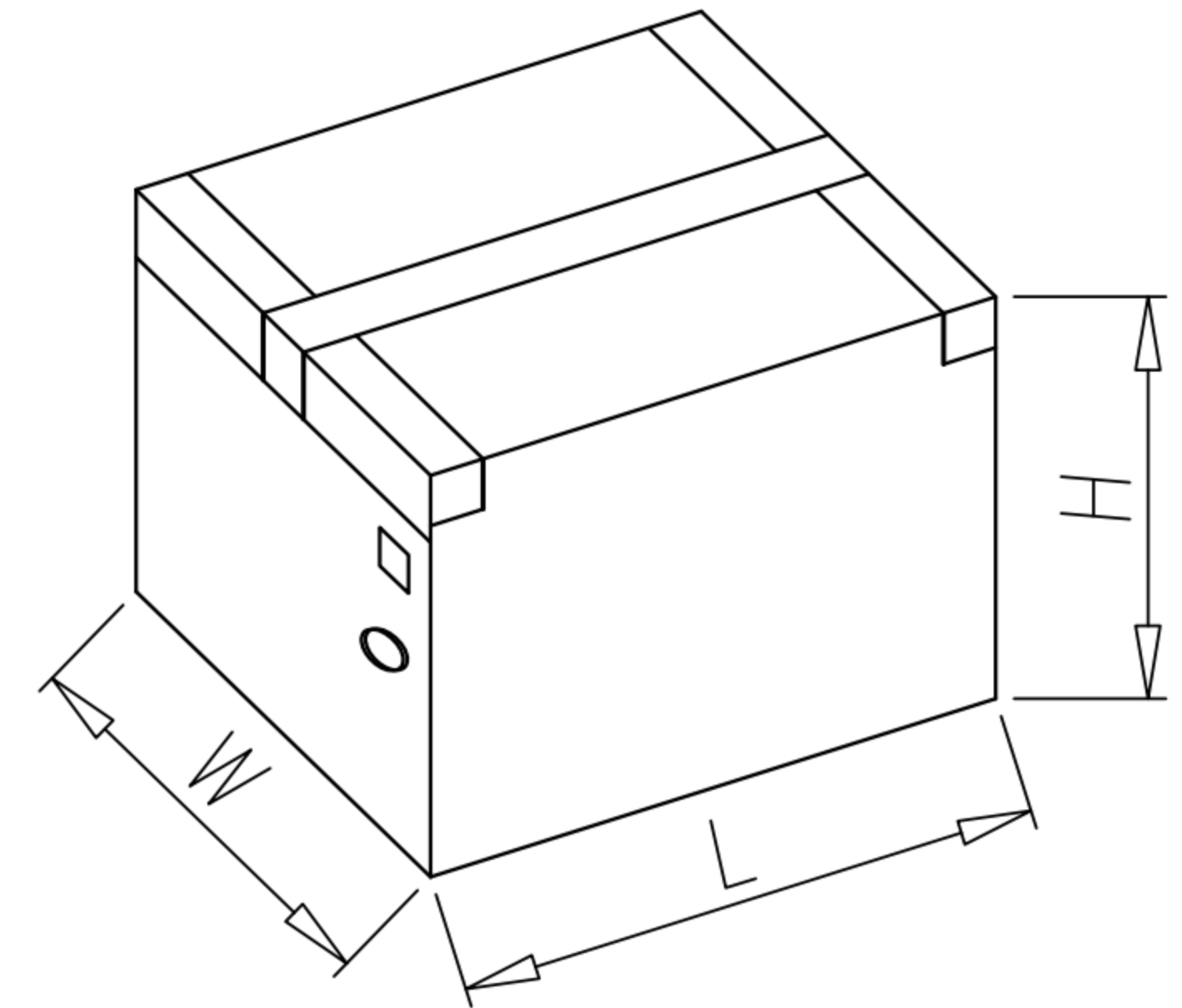

PASTE THE TAPE LABEL AND RoHS LABEL ON CARTON BOXES AS DRAWING

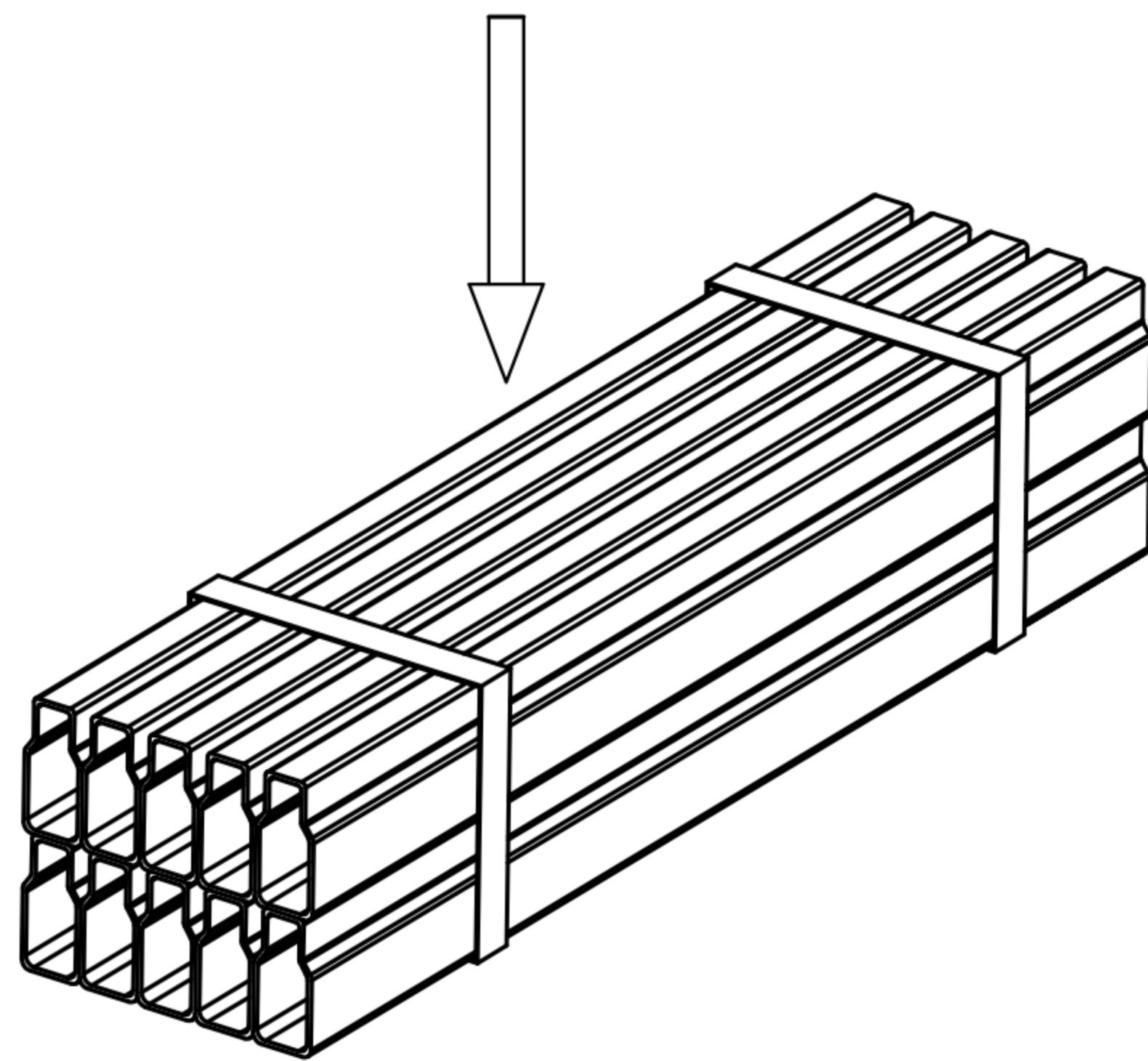

PUT 10 TUBES ON STACK AND PASTE THE TAPE AS DRAWING

PACKING MATERIAL

PM NAME	PM NO.	DIM.(LxWxH)/mm	QUANTITY
TUBE	PK-MU0004	365X6.8X15	600
CARTON BOXES	CB-003	415X297X242	1

PACKING QUANTITY

PCS/TU	PCS/STACK	PCS/CB
38PCS/TU	380PCS/STACK	22800PCS/CB

DRAWN	Mark Kao	APP'D	Ku Chou	UNIT	mm	TOLERANCE		广东科斯达电子科技有限公司 GUANG DONG KE SI DA ELECTRONIC TECHNOLOGY CO., LTD.	TITLE	MINI USB PLUG,10 PINS,GABLE MOUNT			SHEET
CHK'D	Emily Suen			SCALE	1:1	.x ±0.20 .xx ±0.10 .xxx ±0.05 .xxxx ±0.03 ANGULA ±1°			PART NO.	SEE TABLE A	DWG NO.	QC1680	

CUSTOMER DRAWING

REV.	DESCRIPTION	APPROVED BY	DATE	ECN NO.
F	RELEASE	Fido Weng	22/12/08	
G				
H				

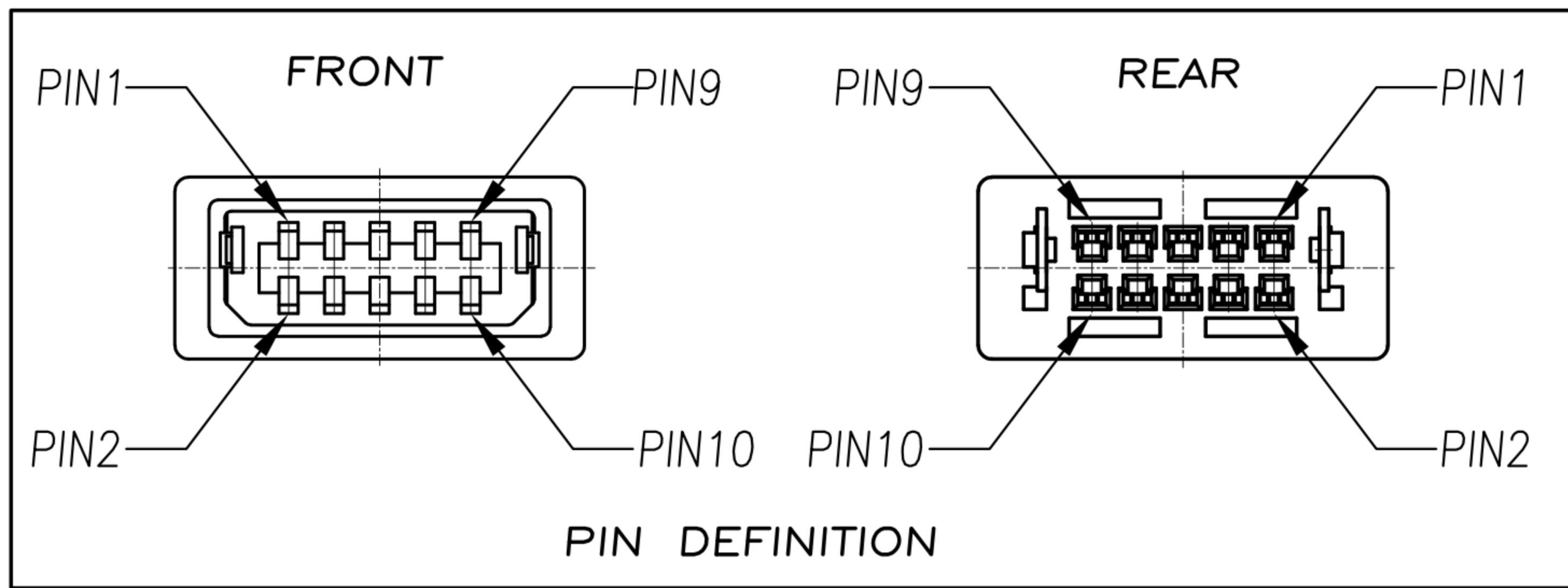
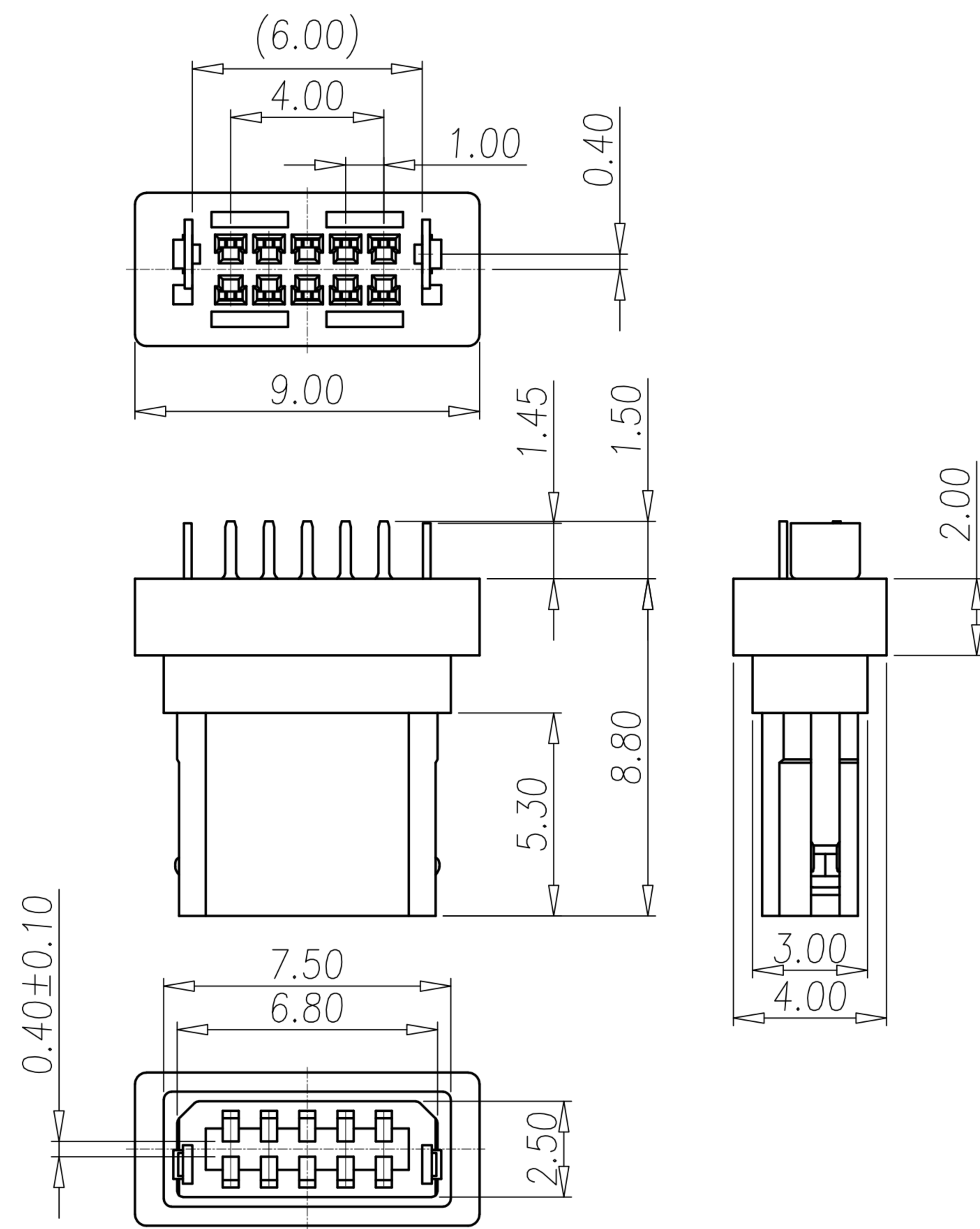

- MATERIAL :
 - 1-1. HOUSING : PBT UL94V-0 ; COLOR : BLACK
 - 1-2. CONTACT : PHOSPHOR BRONZE
 - 1-3. SPRING: PHOSPHOR BRONZE
- FINISH :
 - 2-1. CONTACT A : 10 MICRO INCHES MIN. GOLD PLATED
OTHER AREA:GOLD FLASH
SOLDER TAILS:BRIGHT TIN 60u"
 - 2-2. SPRING: BRIGHT TIN 60u"
UNDERPLATED NICKEL OVER ALL 50u" MIN

TABLE A

MU-10M1-01	BLACK	Au5u"
MU-10M1-03	BLACK	Au30u"
MU-10M1-05	BLACK	Au10u"
P/N	COLOR	PLATING

DRAWN	Mark Kao	APPEND	Ku Chou	UNIT	mm	TOLERANCE		广东科斯达电子科技有限公司 GUANG DONG KE SI DA ELECTRONIC TECHNOLOGY CO., LTD.	TITLE	MINI USB PLUG,10 PINS,GABLE MOUNT			SHEET	
CHKED	Emily Suen			SCALE	1:1	.x ±0.20 .xx ±0.10 .xxx ±0.05 .xxxx ±0.03 ANGULA ±1°			PART NO.	SEE TABLE A	DWG NO.	QC1680	VERSION	