

CUSTOMER DRAWING

REV.	DESCRIPTION	APPROVED BY	DATE	ECN NO.
△A	RELEASE	Yeh Chou	2017/xx/xx	
△B				
△C				
△D				

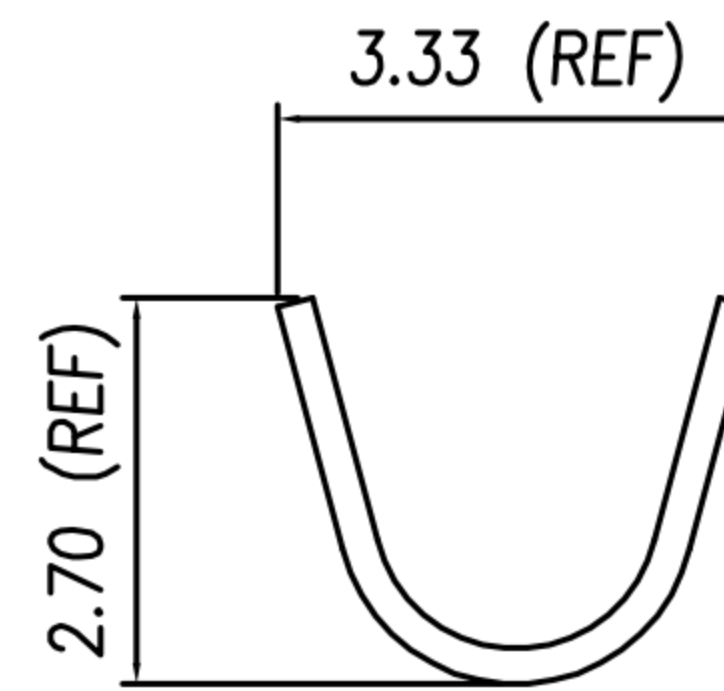

A-A

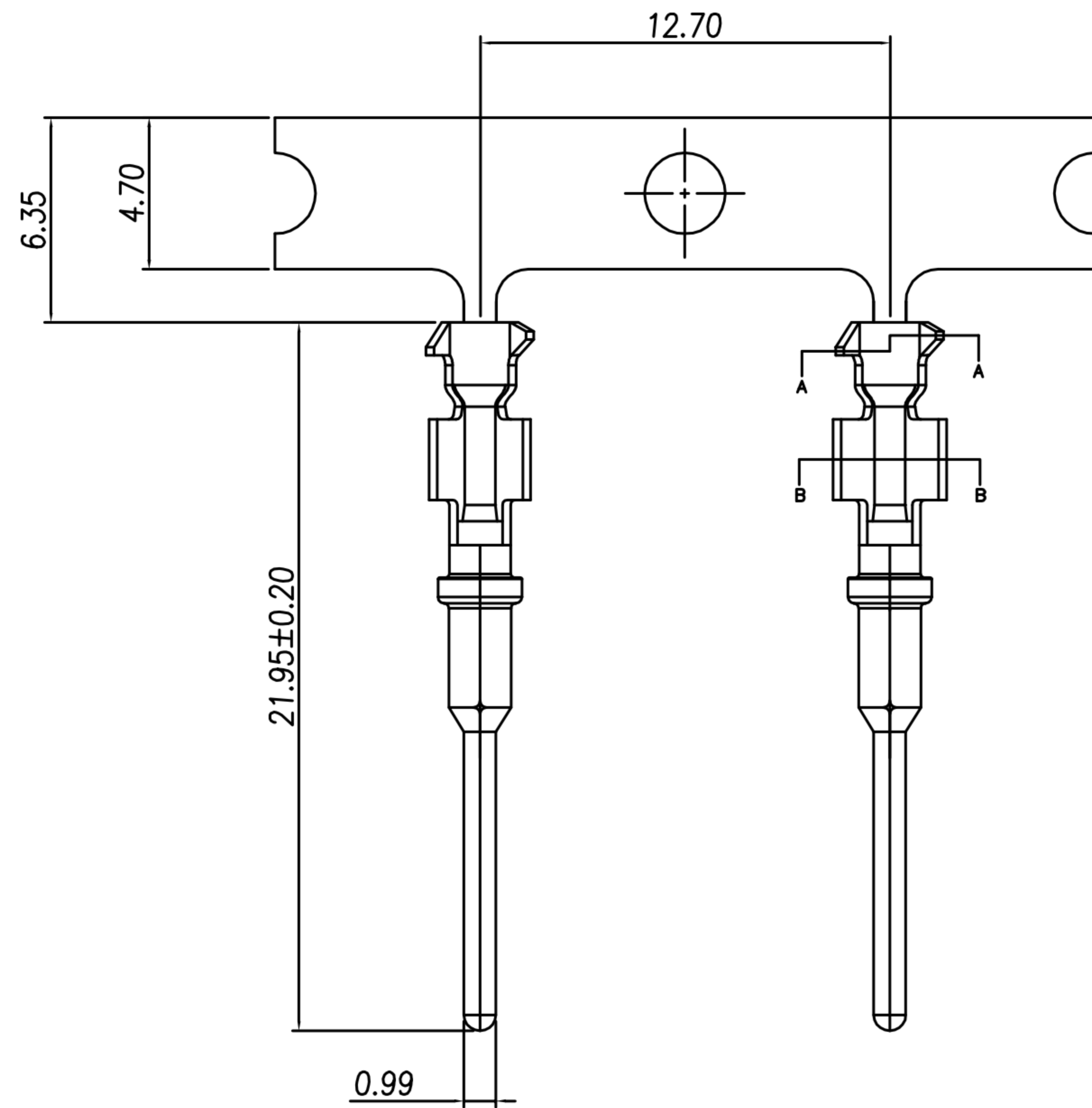
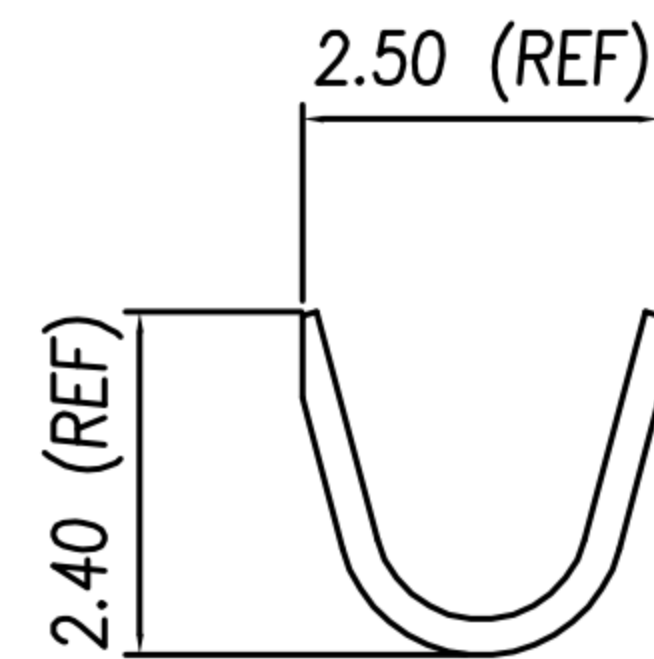

B-B

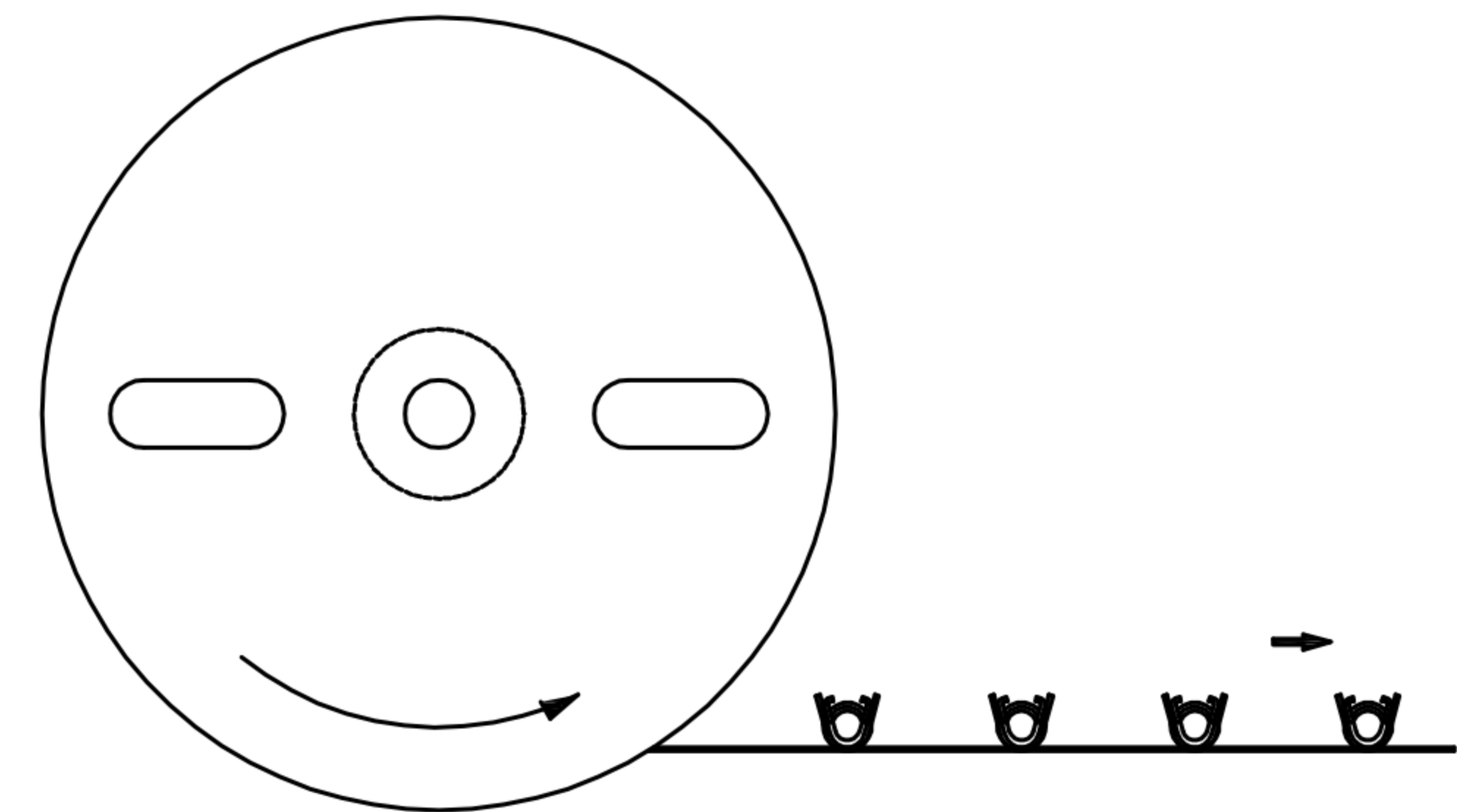
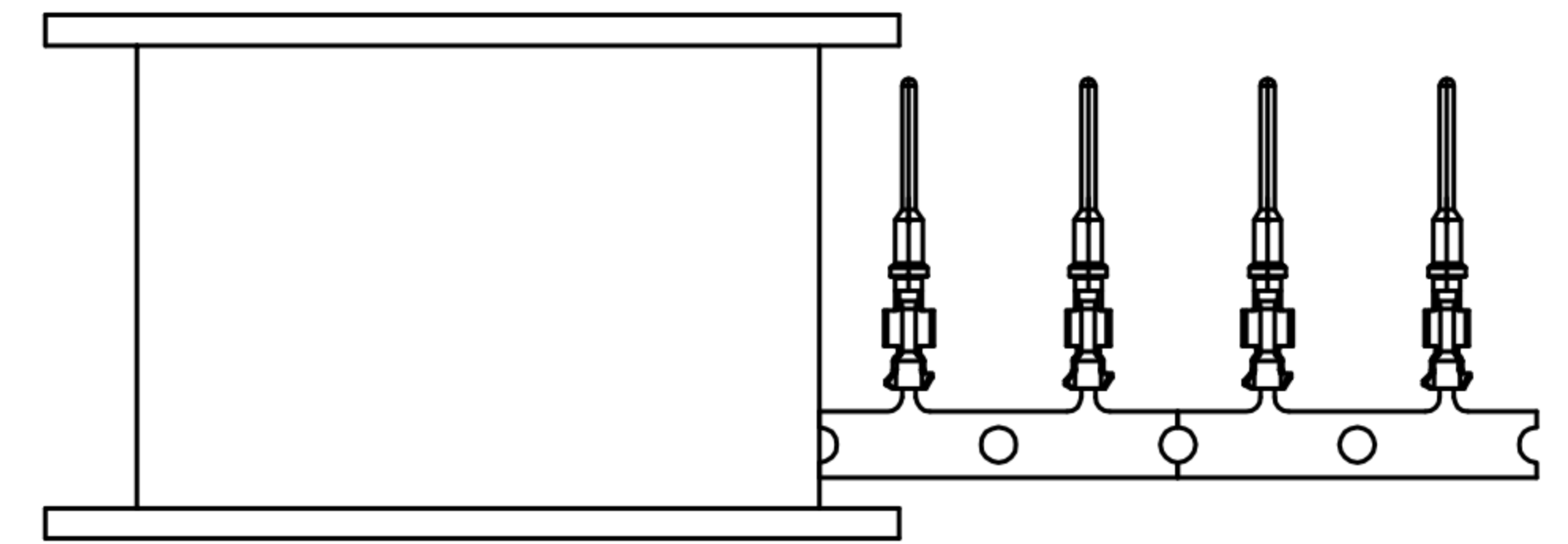

PULL OUT DIRECTION

TABLE A

OY-WP01134-00	防水頭12PIN (M) 端子(Crimp PIN 20~28AWG)	MATTE TIN 80u"~100u"
OY-WP01135-00	防水頭12PIN (M) 端子(Crimp PIN 20~28AWG)	NICKEL 80u"~100u"
OY-WP11134-00	防水頭12PIN (M) 端子(Crimp PIN 20~28AWG)(素)	素材
P/N	TITLE	FINISH

- MATERIAL :
 - CONTACT : PHOSPHOR BRONZE
 - SHELL : STAINLESS STEEL
- FINISH :
 - CONTACT : SEE TABLE A

DRAWN	Yeh Chou	APPVL	UNIT	mm	TOLERANCE		TITLE	SEE TABLE A			SHEET
CHK'D			SCALE	1:1	.x ±0.20 .xx ±0.10 .xxx ±0.05 .xxxx ±0.03 ANGULA ±1°		广东科斯达电子科技有限公司 GUANG DONG KE SI DA ELECTRONIC TECHNOLOGY CO., LTD.	PART NO.	SEE TABLE A	DWG NO.	QC8192