

CUSTOMER DRAWING

REV.	DESCRIPTION	APPVL. BY	DATE	ECN NO.
A	RELEASE	Fido Weng	22/12/08'	
B	CHANGE HOUSING COLOR	Fido Weng	14/05/09'	ECN09065
C				

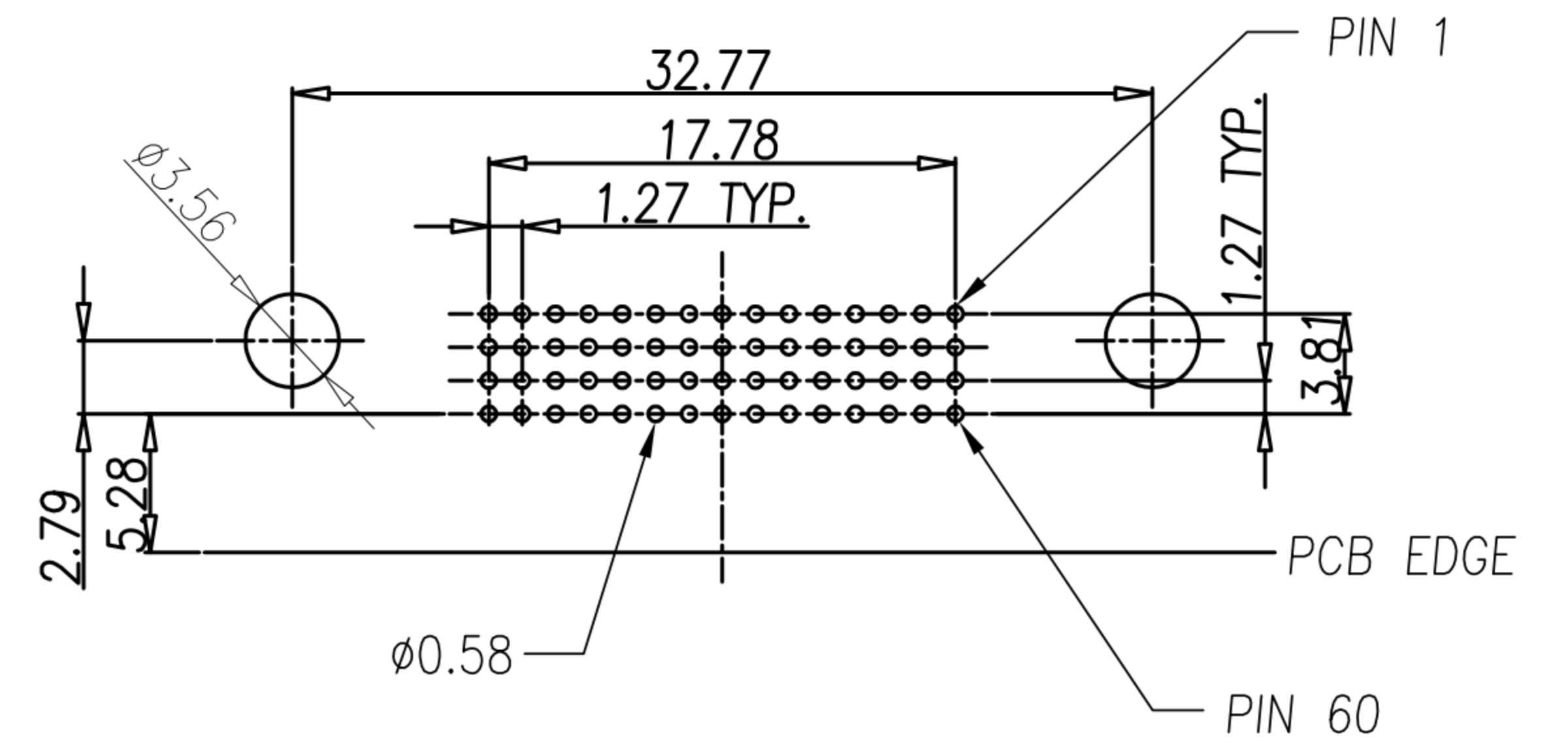

RECOMMENED PCB LAYOUT
TOLERANCE ±0.05mm $\triangle B$

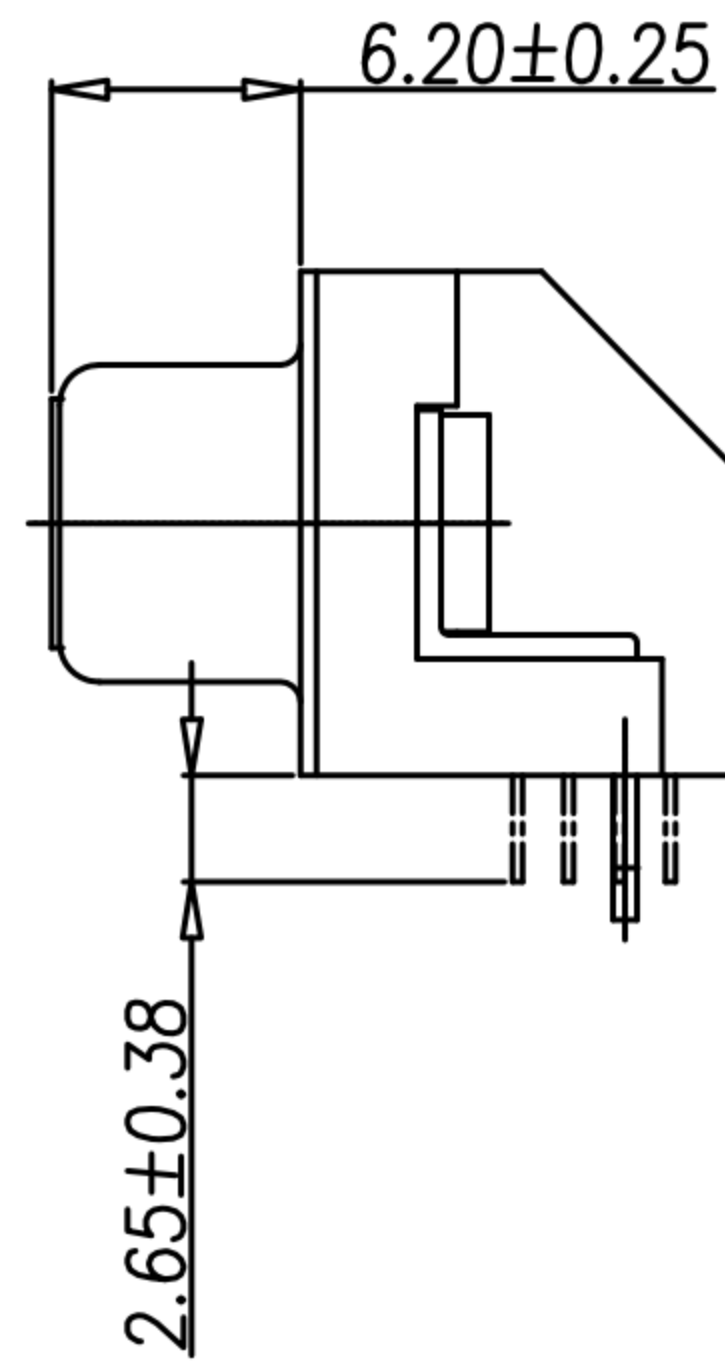
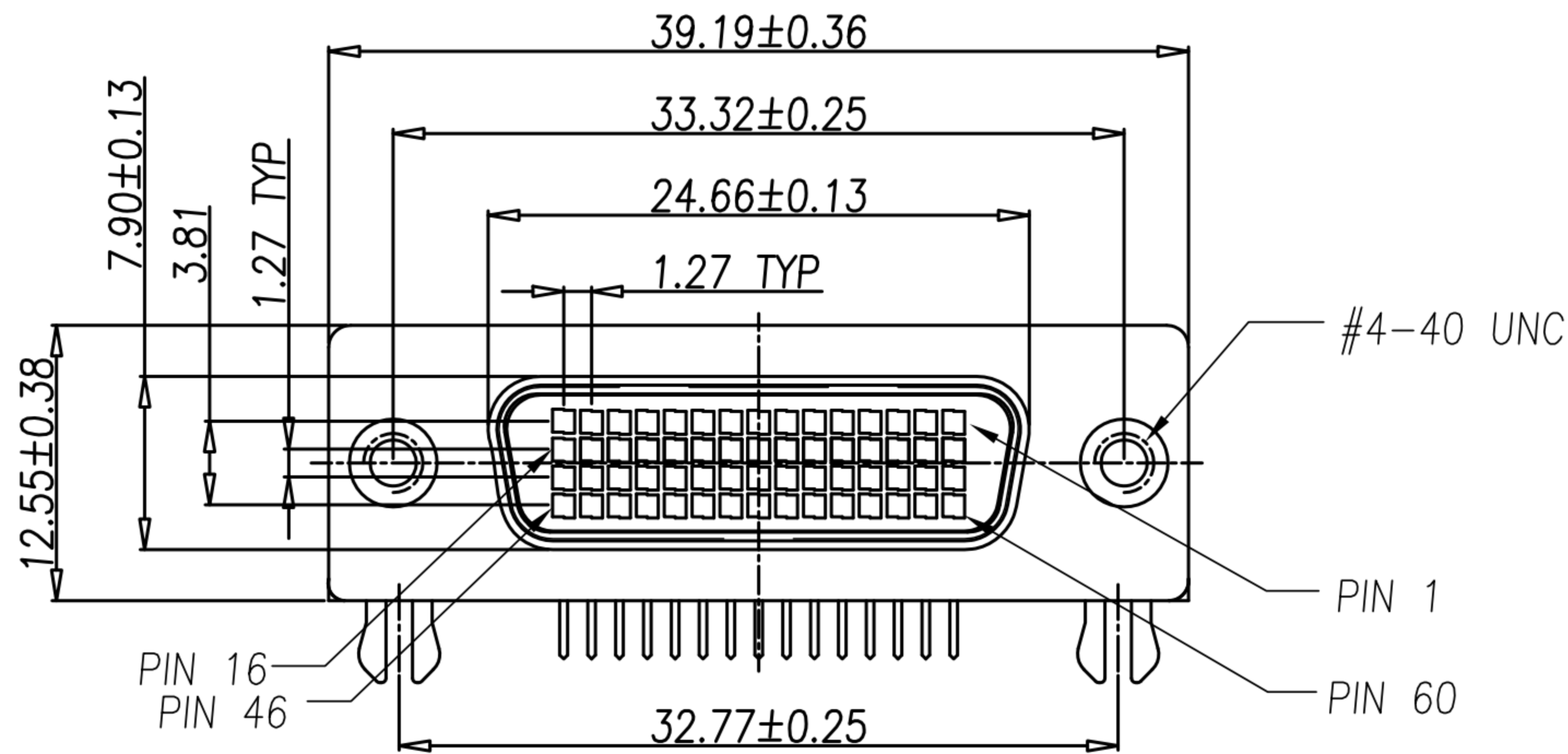
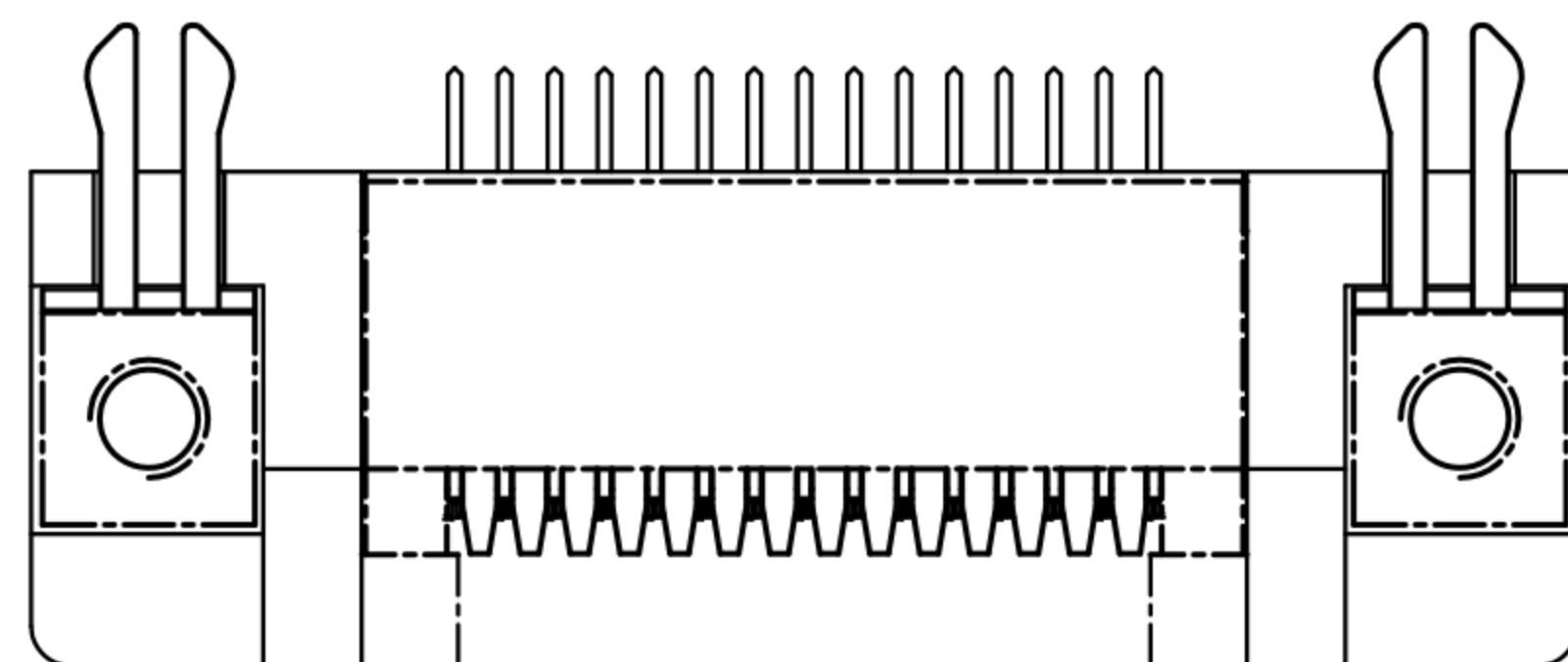
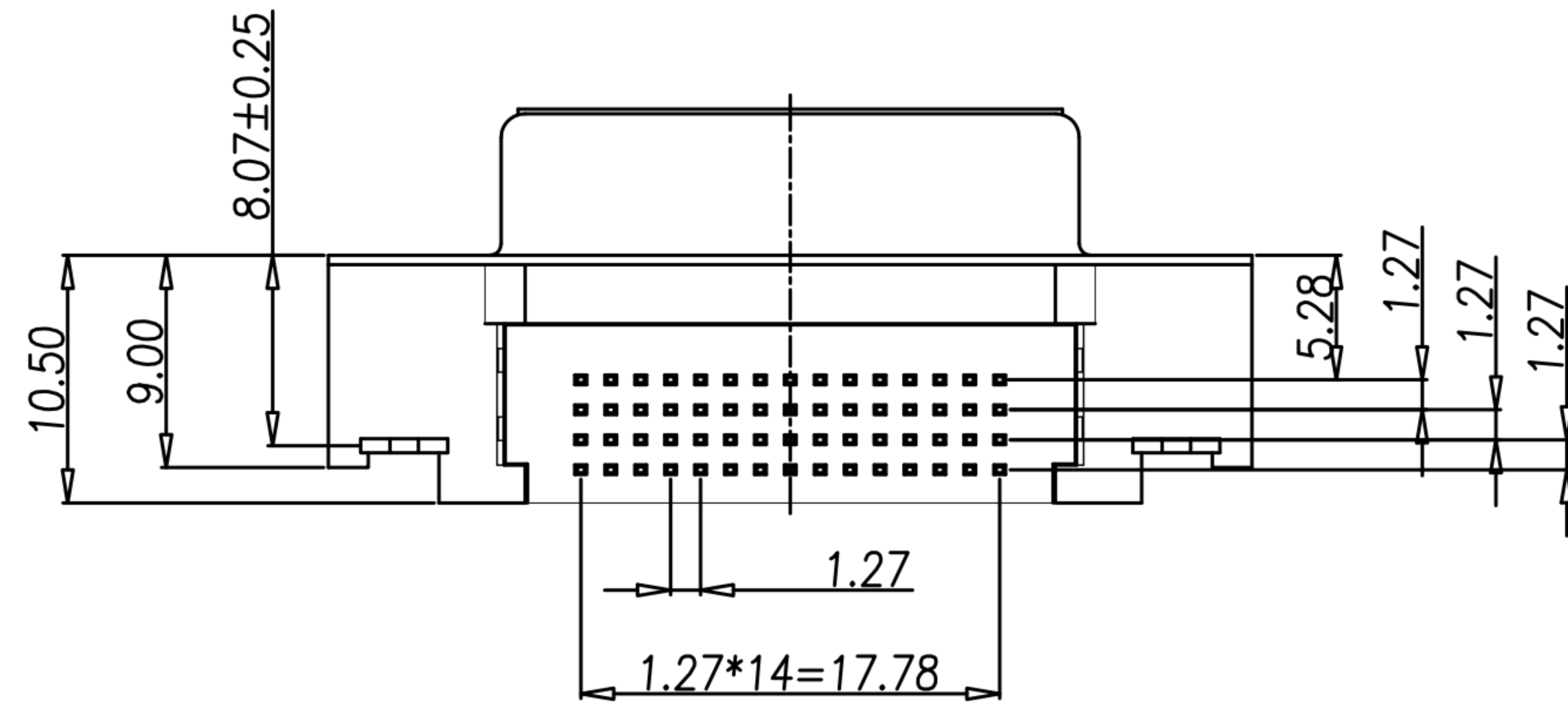

NOTES

1. MATERIAL :
 - 1-1. HOUSING : LCP UL94V-0 ; COLOR : GRAY WHITE
 - 1-2. CONTACT : PHOSPHOR BRONZE
 - 1-3. SHELL : SPCC
 - 1-4. BOARD LOCK : BRASS
 - 1-5. SCREW : BRASS
 - 1-6. COVER : LCP UL94V-0 ; COLOR : GRAY WHITE
2. FINISH :
 - 2-1. CONTACT :
CONTACT AREA : GOLD FLASH PLATED
SOLDER AREA : GOLD FLASH PLATED
UNDER PLATE : NICKEL
 - 2-2. SHELL : NICKEL PLATED.
 - 2-3. BOARD LOCK : BRIGHT TIN PLATED.
 - 2-4. SCREW : NICKEL PLATED

DRAW	Mark Kao	APPVL	Ku Chou	UNIT	mm	TOLERANCE .x ±0.20 .xx ±0.10 .xxx ±0.05 .xxxx ±0.03 ANGULA ±1°		广东科斯达电子科技有限公司 GUANG DONG KE SI DA ELECTRONIC TECHNOLOGY CO., LTD.	TITLE	RS-6000 60P (1.27) RIGHT ANGLE			SHEET	B
CHECK	Emily Suen			SCALE	1:1				PART NO.	LFH-60F1-03	DWG NO.	QC3054	VERSION	