

CUSTOMER DRAWING

REV.	DESCRIPTION	APPROVED BY	DATE	ECN NO.
△A				
△B	修改外觀總長&端子改杯口	Fido Weng	09/09/13'	
△C				

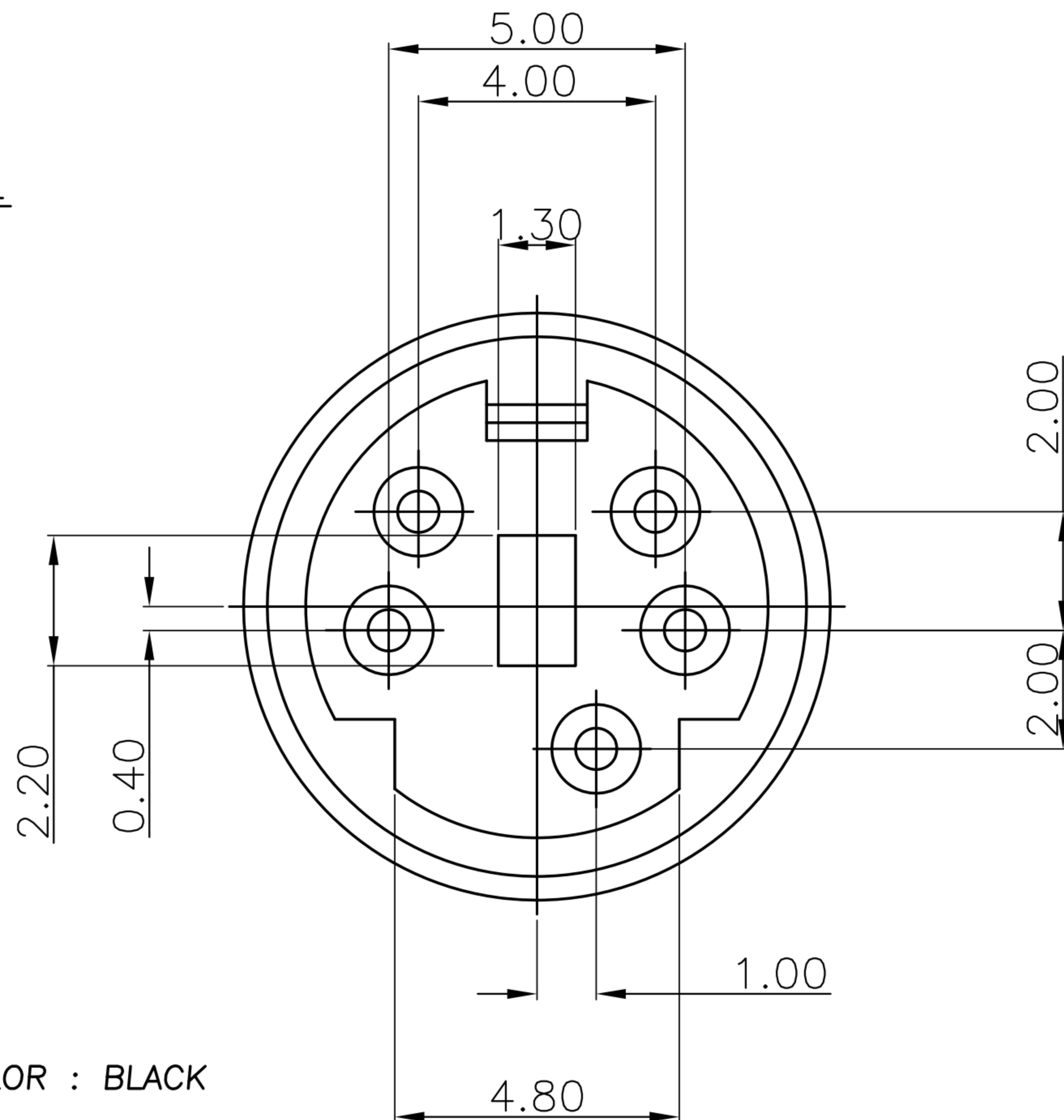
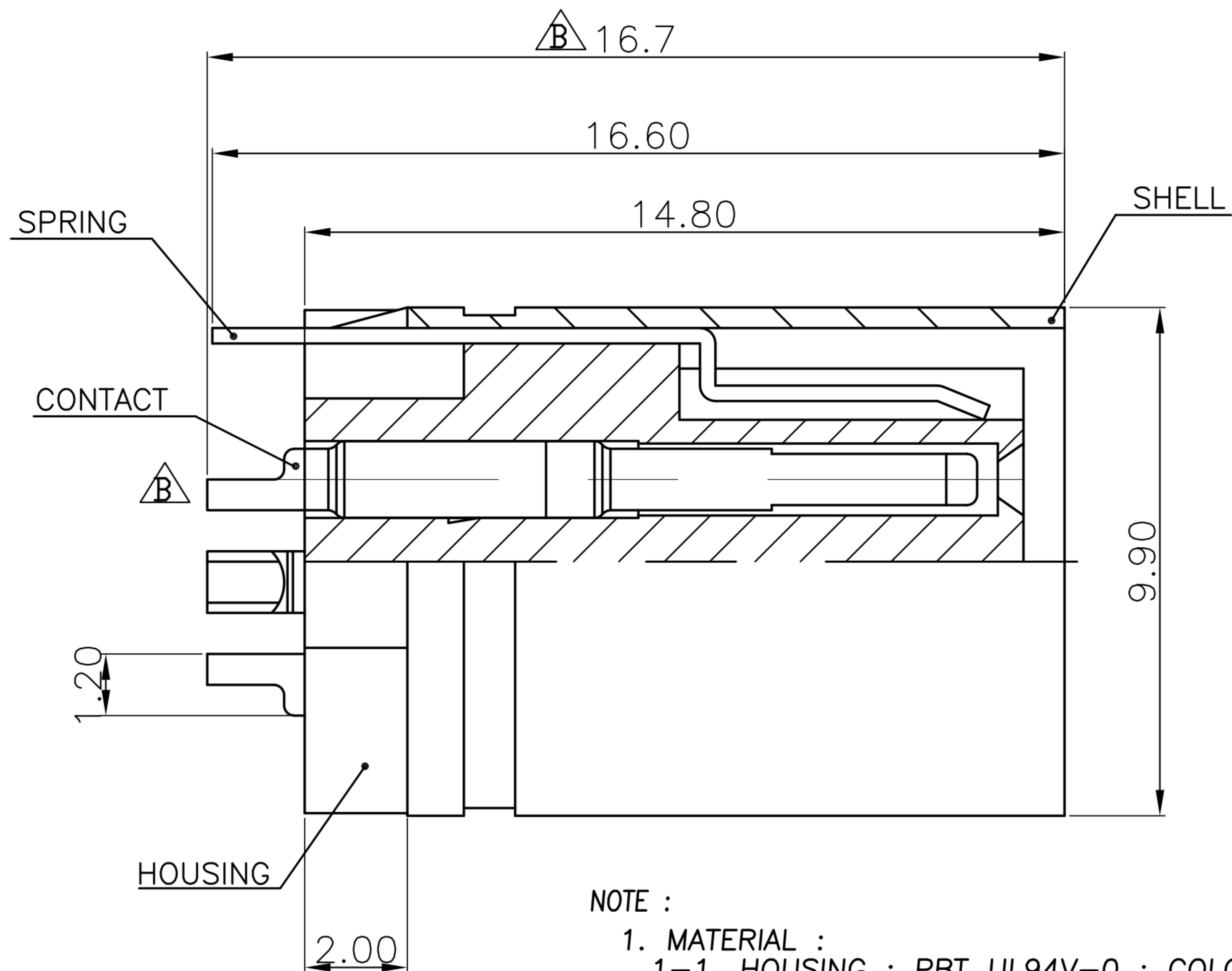

NOTE :

1. MATERIAL :
 - 1-1. HOUSING : PBT UL94V-0 ; COLOR : BLACK
 - 1-2. CONTACT : PHOSPHOR BRONZE
 - 1-3. SHELL : BRASS
 - 1-4. SPRING : PHOSPHOR BRONZE
2. FINISH :
 - 2-1. CONTACT : SEE TABLE A
 - 2-2. SHELL : NICKEL PLATED
 - 2-3. SPRING : SILVER PLATED
3. ELECTRICAL SPECIFICATION :
 - 3-1. Rated current : 2A
 - 3-2. Rated voltage : 12V

TABLE A

P/N	DESCRIPTION	FINISH	SPRING
MD-05F1-05	MD 5S(銀)成品 無彈片	SILVER PLATED	NO
MD-05F1-04	MD 5S(表金)成品	GOLD FLASH PLATED	YES
MD-05F1-03	MD 5S(銀)成品	SILVER PLATED	YES

DRAWN	LILY QIN	APP'D	Ku Chou	UNIT	mm	TOLERANCE		广东科斯达电子科技有限公司 GUANG DONG KE SI DA ELECTRONIC TECHNOLOGY CO., LTD.	TITLE	SEE TABLE A			SHEET	VERSION B
CHK'D	Emily Suen			SCALE	1:1	.x ±0.20 .xx ±0.10 .xxx ±0.05 .xxxx ±0.03 ANGULA ±1°			PART NO.	SEE TABLE A	DWG NO.	QC0009		