

CUSTOMER DRAWING

REV.	DESCRIPTION	APPVL. BY	DATE	ECN NO.
△A				
△B				
△C				

步驟一:

1. 將成品一一放入包裝盤內, 依同一方向置入.
2. 包裝方式, 如圖所示.
3. 包裝數量如下: 9P 96pcs/盤
15P 80pcs/盤
25P 64pcs/盤
5. 層疊10盤後, 在以膠膜固定

步驟二:

1. 一個紙箱可以裝7個包裝盤.
2. 每箱7盤, 數量如下: 9P 672pcs/箱
15P 560pcs/箱
25P 448pcs/箱
3. 將包裝盤放紙箱中, 後封箱.

步驟三:

1. 用膠帶將紙箱封實.
2. 將標籤貼於紙箱上.

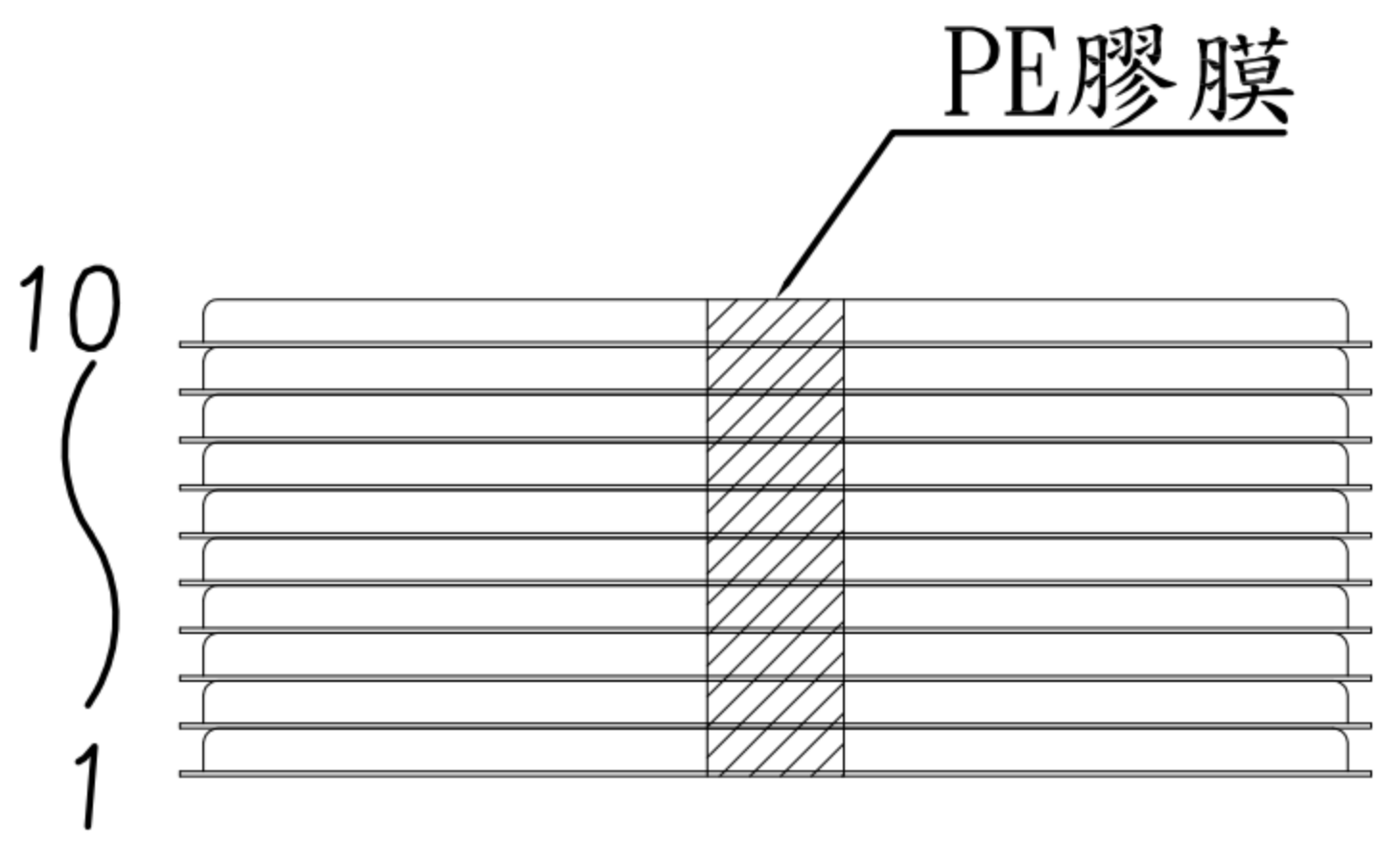
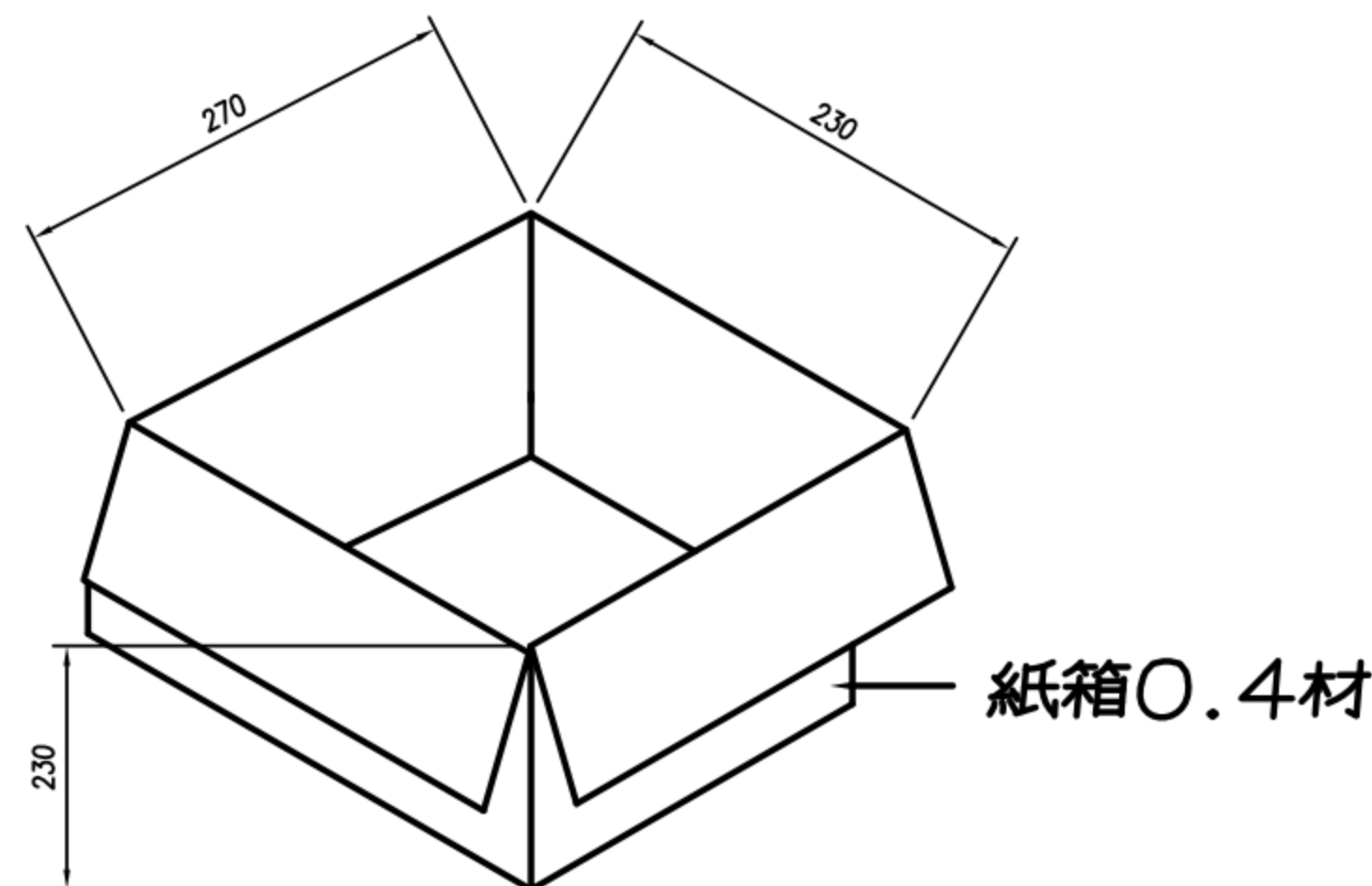
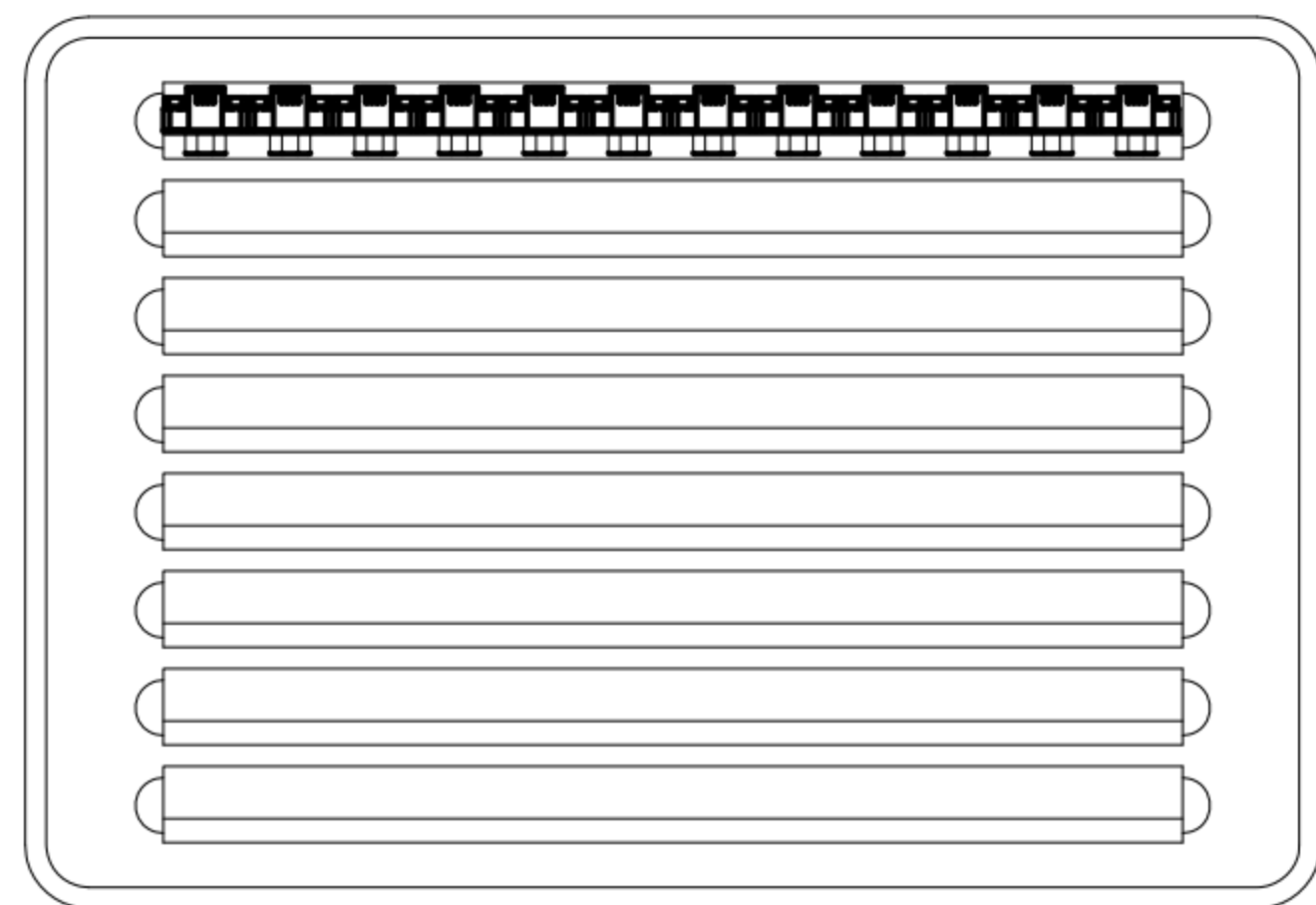
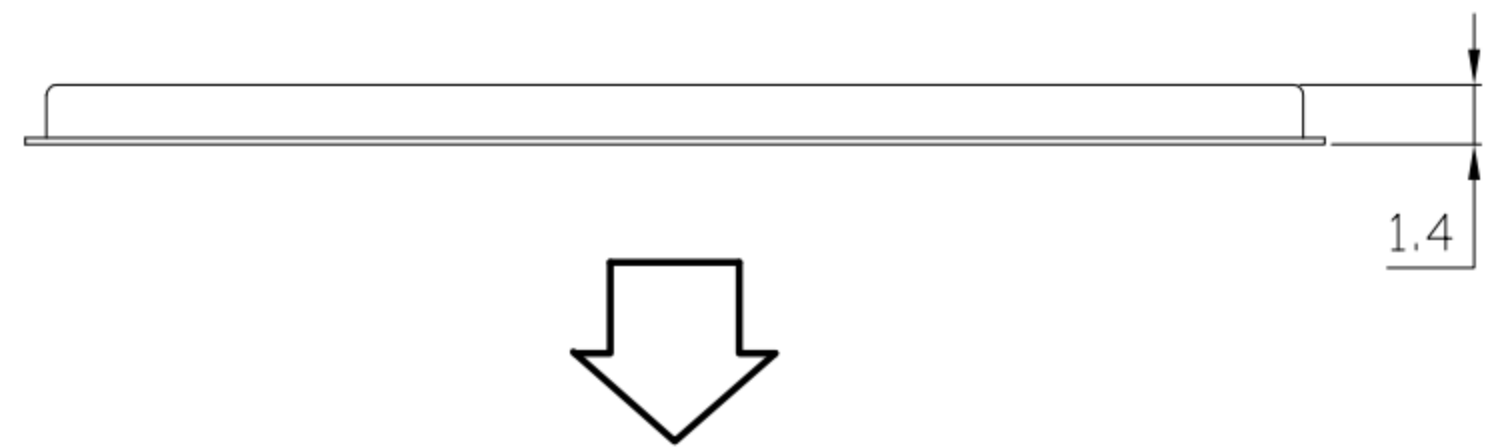
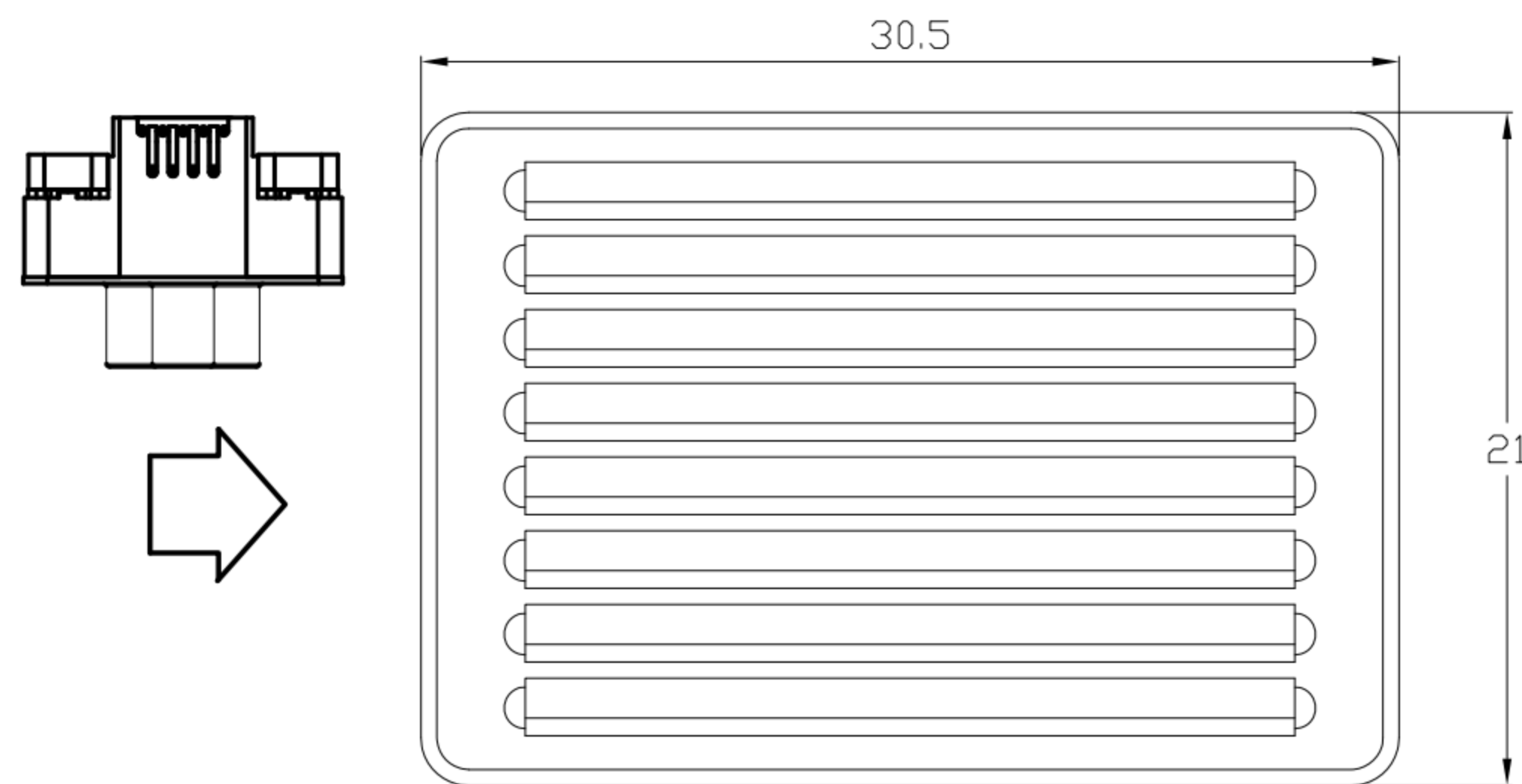

ITEM NO:
QTY: PGS
N. W. : KG
G. W. : KG
MEAS:

標籤處

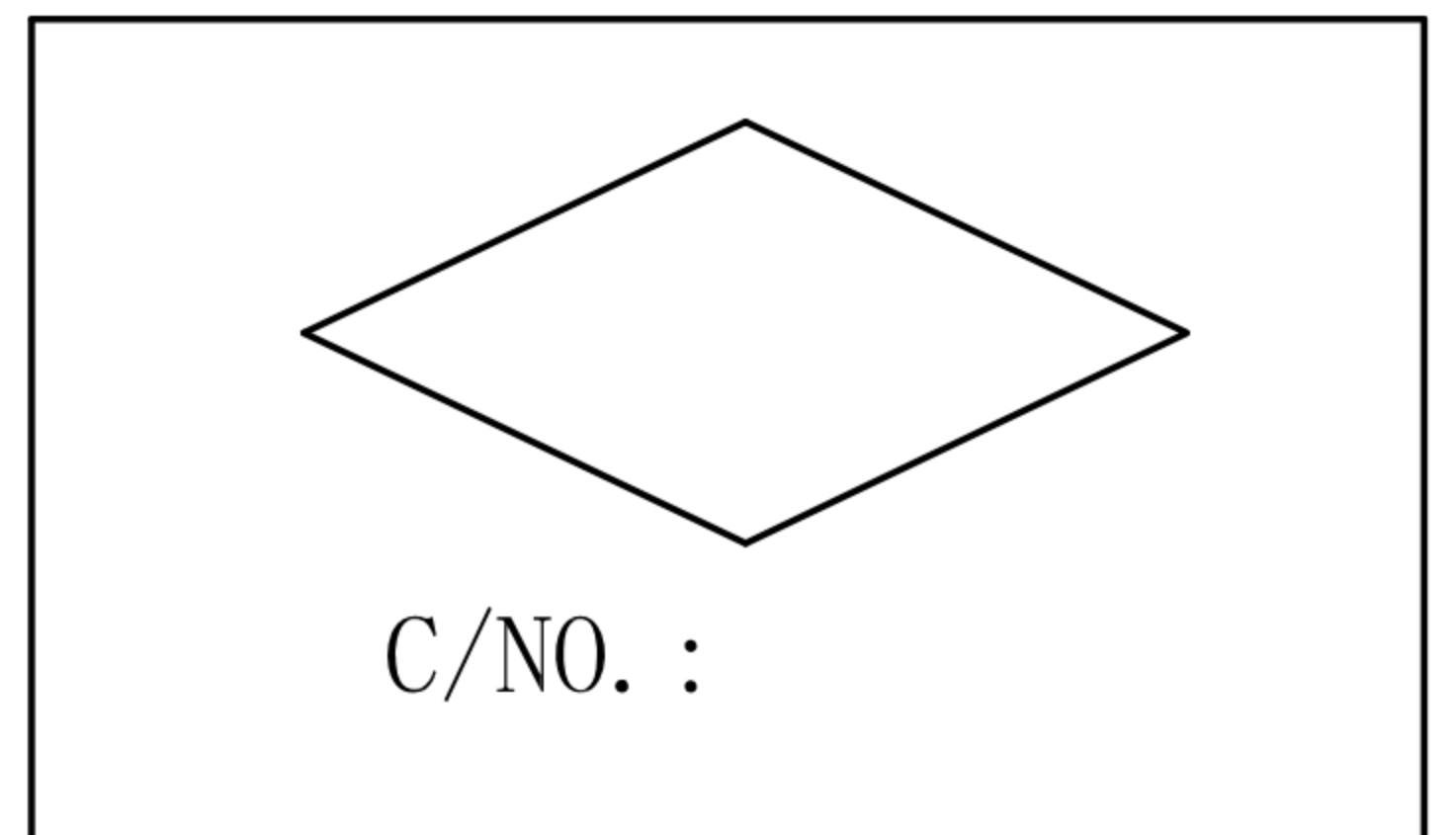

NOTE:

1. 若有未裝滿之零數箱, 必須以緩衝材塞滿.
2. 在搬運過程中要輕拿輕放.
3. 載運輸中不可堆放過多, 不可有重壓現象.
4. PE膠膜纏繞時不可緊綁.
5. 紙箱內層需裝防水袋.

P/N	NUMBER OF PINS
DB-09F3-01	9
DB-15F3-01	15
DB-25F3-01	25

CUSTOMER DRAWING

REV.	DESCRIPTION	APPROVED BY	DATE	ECN NO.
A	RELEASE	Emily Suen	07/12/2011'	
B				
C				

P/N	NUMBER OF PINS	A	B	C	D	E	F	G
DB-09F3-01	9	19.93	14.35	5.08	14.35	10.41	14.35	8.30
DB-15F3-01	15	23.75	18.16	8.89	18.16	14.22	18.16	12.20
DB-25F3-01	25	30.10	24.51	15.23	24.51	20.57	24.51	18.55

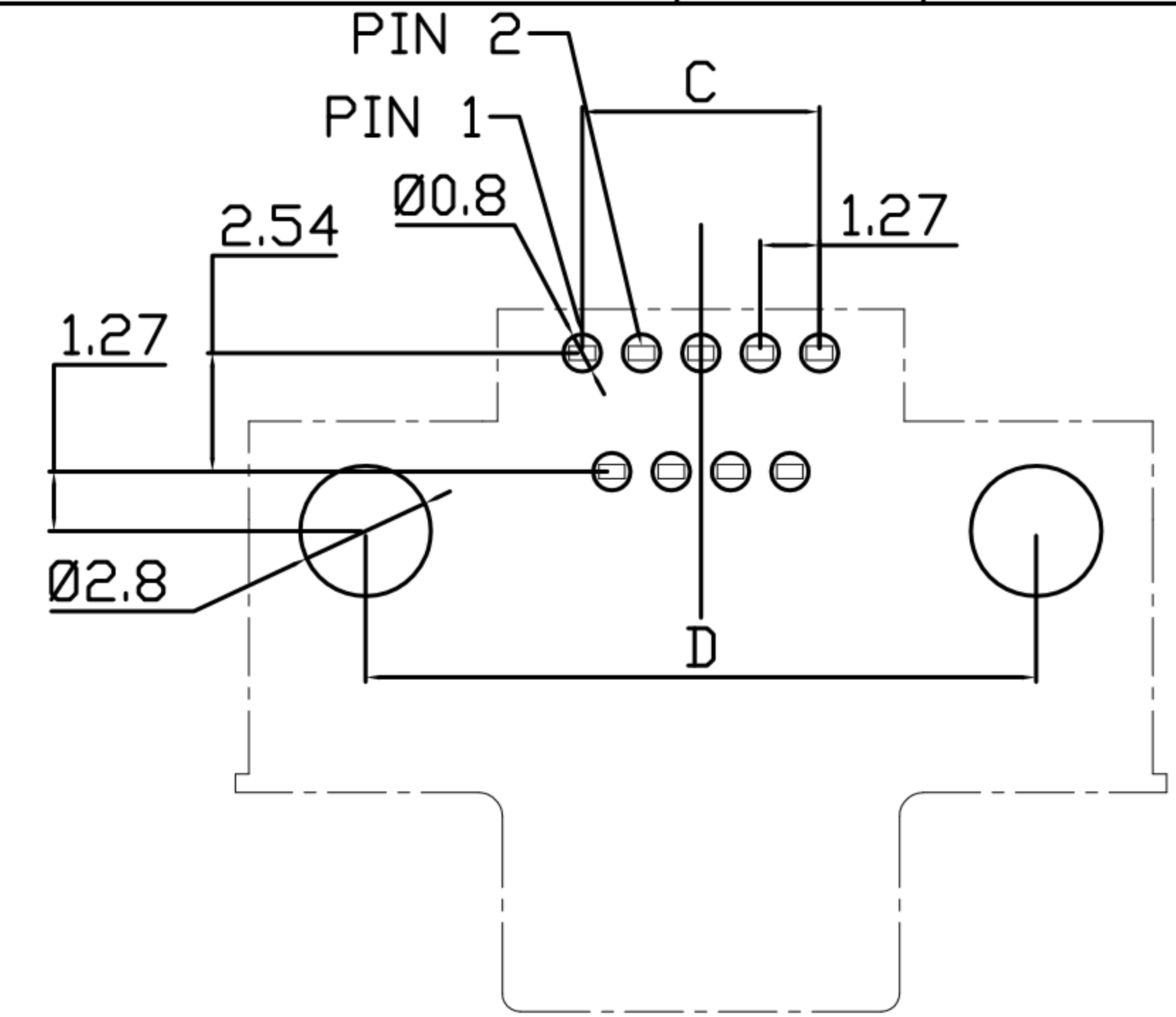
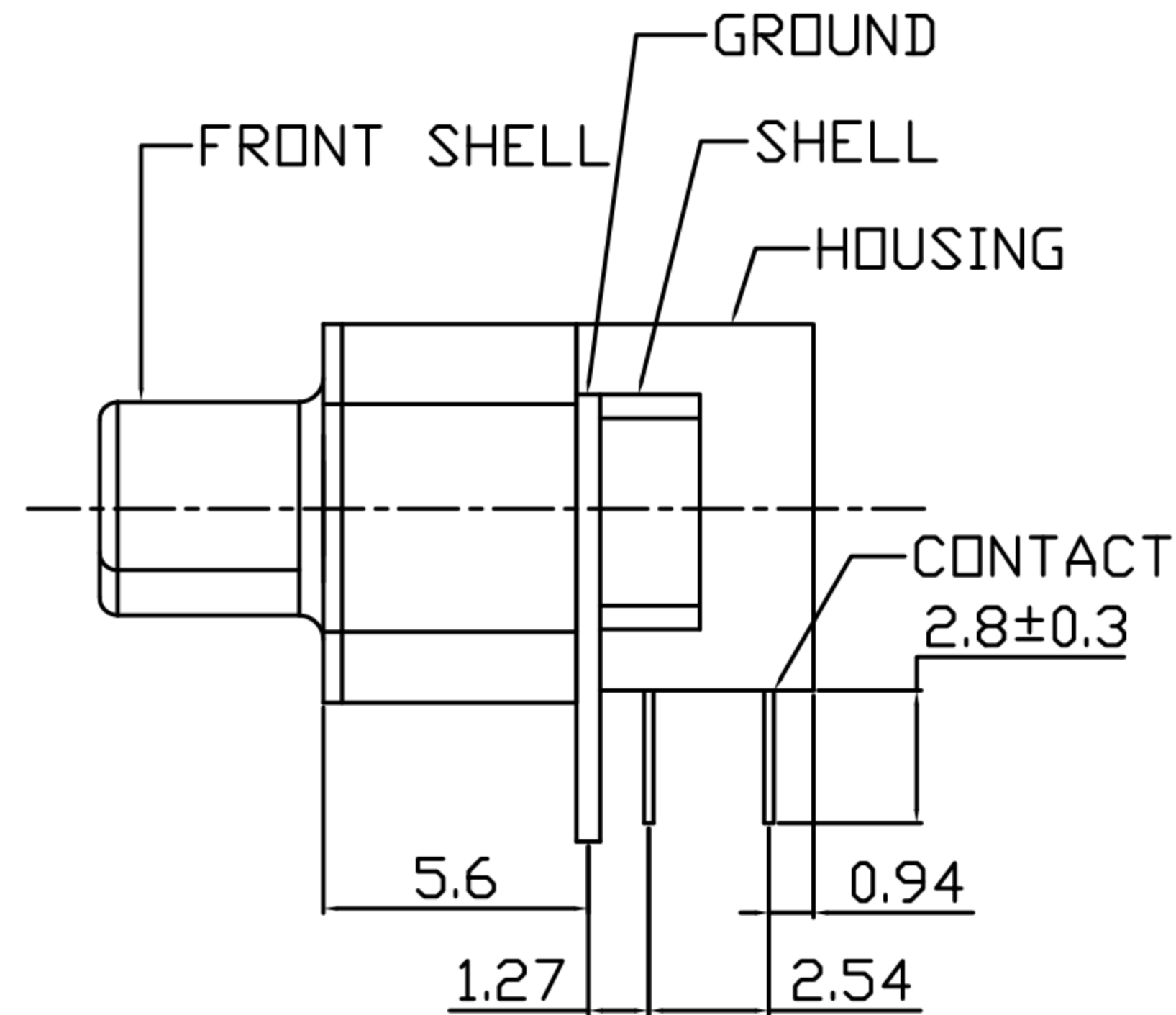
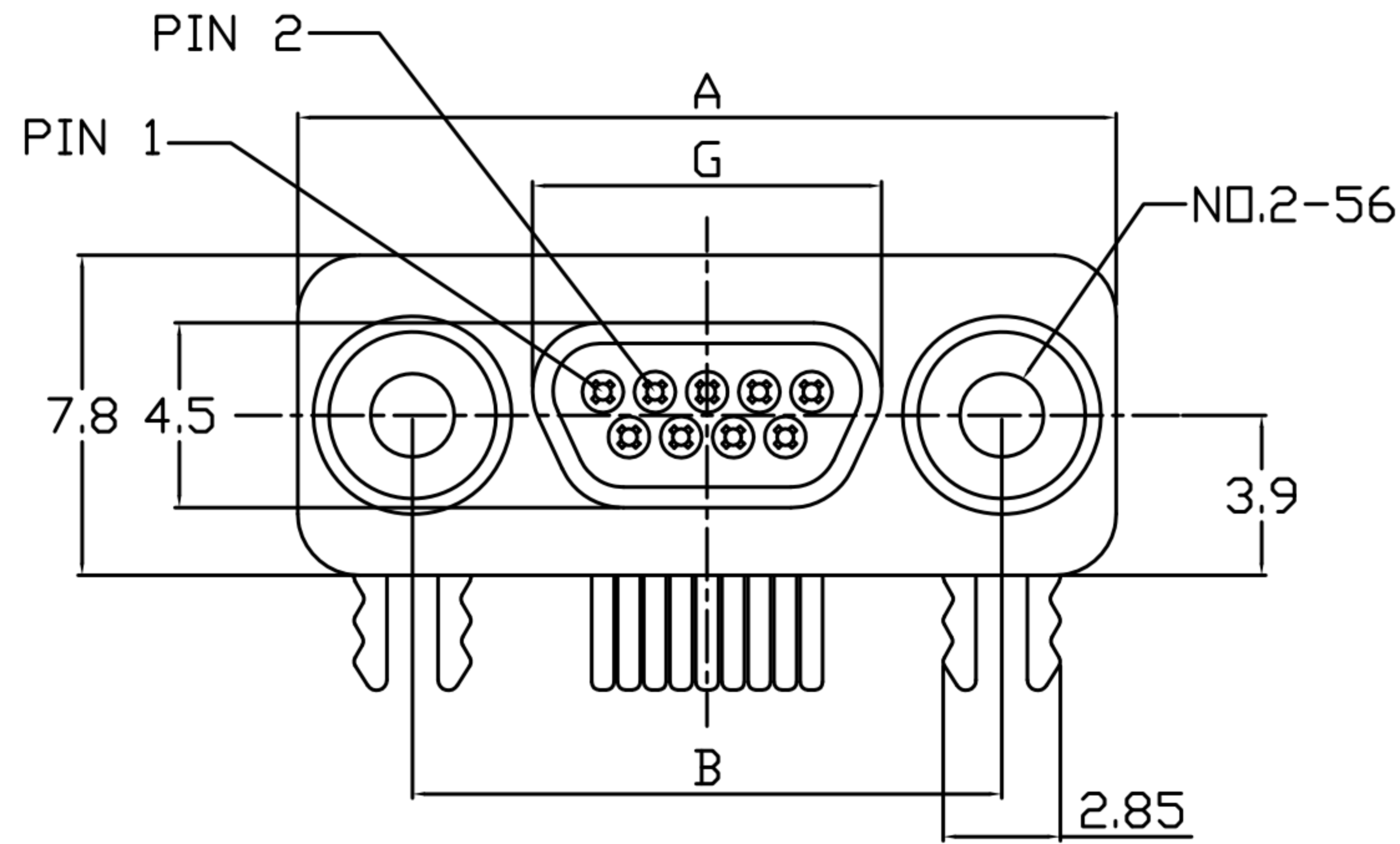

P.C.B LAYOUT

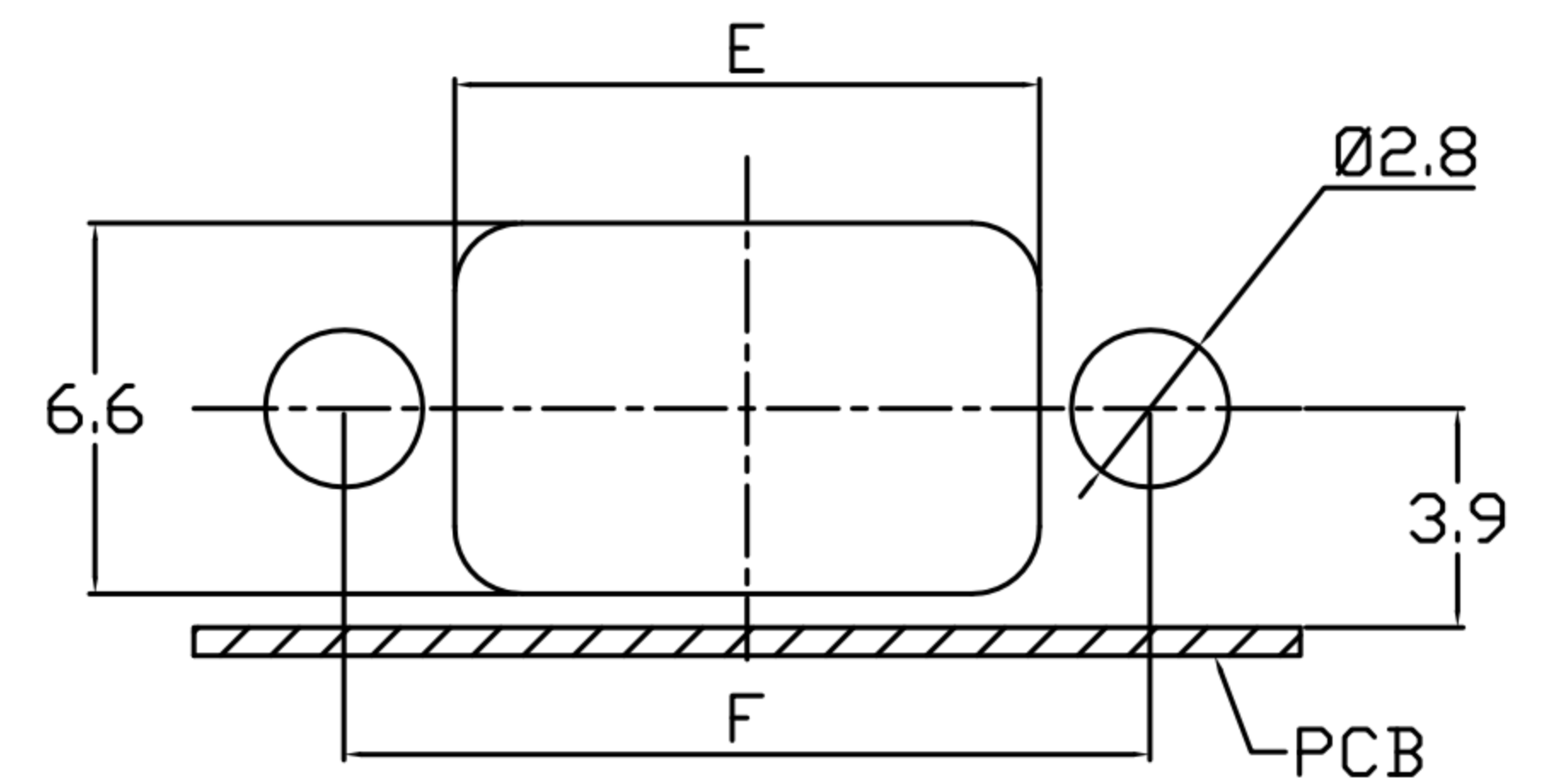
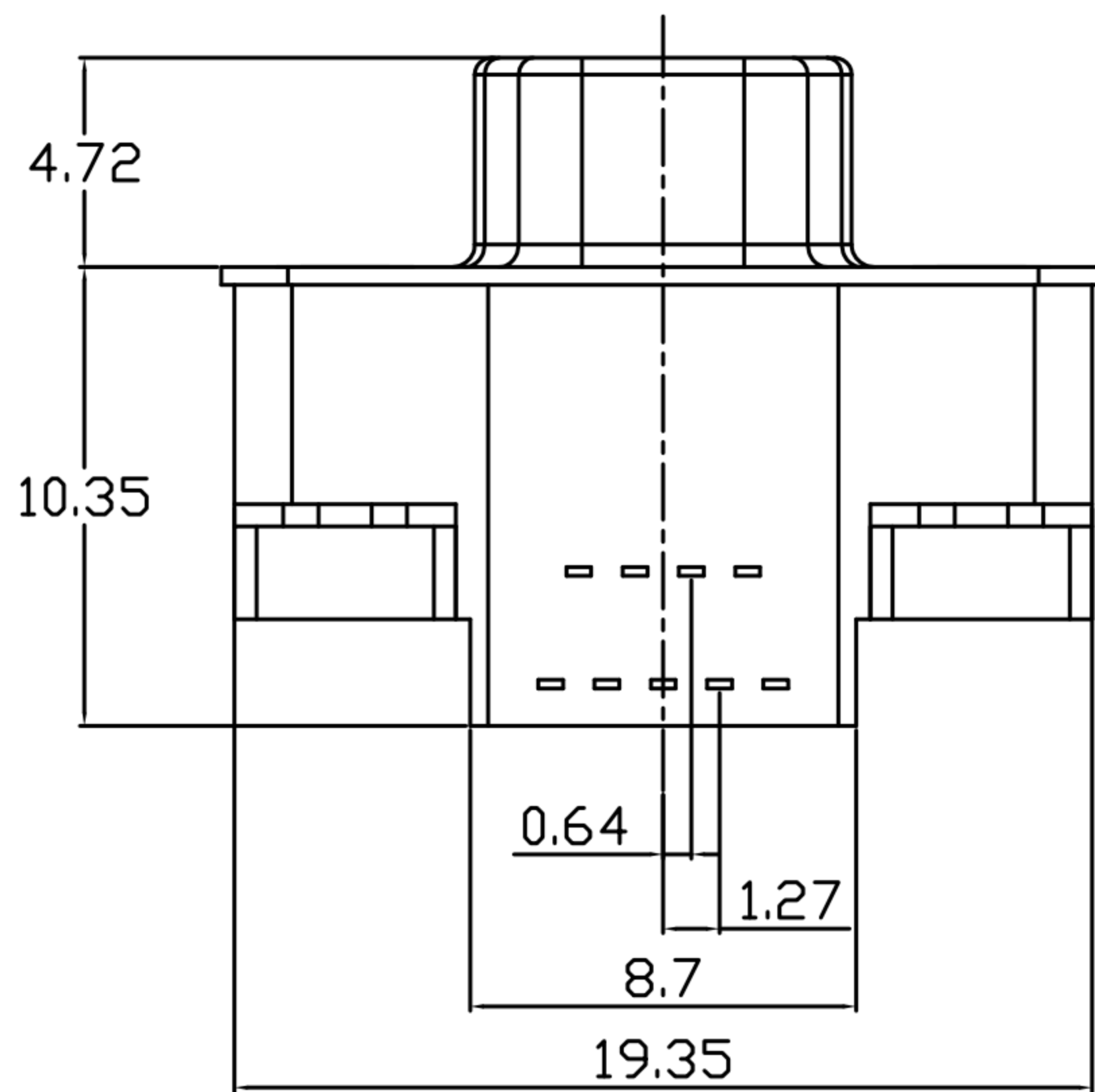

PANEL CUT-OUT

- MATERIAL :
 - HOUSING : LCP UL94V-0 ; COLOR : BLACK
 - CONTACT : PHOSPHOR BRONZE
 - FRONT SHELL : SPCC
 - SHELL : BRASS
 - GROUND : BRASS
- FINISH :
 - CONTACT : GOLD 15u" ON CONTACT AREA
MATTE TIN 60u" ON SOLDER AREA
 - FRONT SHELL : NICKEL PLATED 60u" ~ 100u" OVER ALL
 - SHELL : NICKEL PLATED 60u" ~ 100u" OVER ALL
 - GROUND : NICKEL PLATED 60u" ~ 100u" OVER ALL
- ELECTRICAL SPECIFICATION :
 - Rated current : 1A
 - Voltage : 30V
- Environmental :
 - Operation Temperature : -40°C~+125°C

DRAWN	Yeh Chou	APP'D	Ku Chou	UNIT	mm	TOLERANCE			TITLE	MICRO D-SUB 9-25P(F) 板上90°			SHEET	1/1
CHK'D	Emily Suen			SCALE	1:1	.x ±0.20 .xx ±0.15 .xxx ±0.10 .xxxx ±0.05 ANGULA ±1°			PART NO.	SEE TABLE A	DWG NO.	QC4934	VERSION	A