

CUSTOMER DRAWING

REV.	DESCRIPTION	APPVL. BY	DATE	ECN NO.
A	RELEASE	Fido Weng	28/11/13'	
B				
C				

步驟一:

- 將成品一一放入包裝盤內,依同一方向置入.
- 包裝方式,如圖所示.
- 一個包裝盤500pcs.

步驟二:

- 一個紙箱可以裝10個包裝盤.
- 每盤500pcs,每箱5000pcs.
- 將包裝盤放入防水袋中,包裝完後再封箱.

步驟三:

- 用膠帶將紙箱封實.
- 將標籤貼於紙箱上.

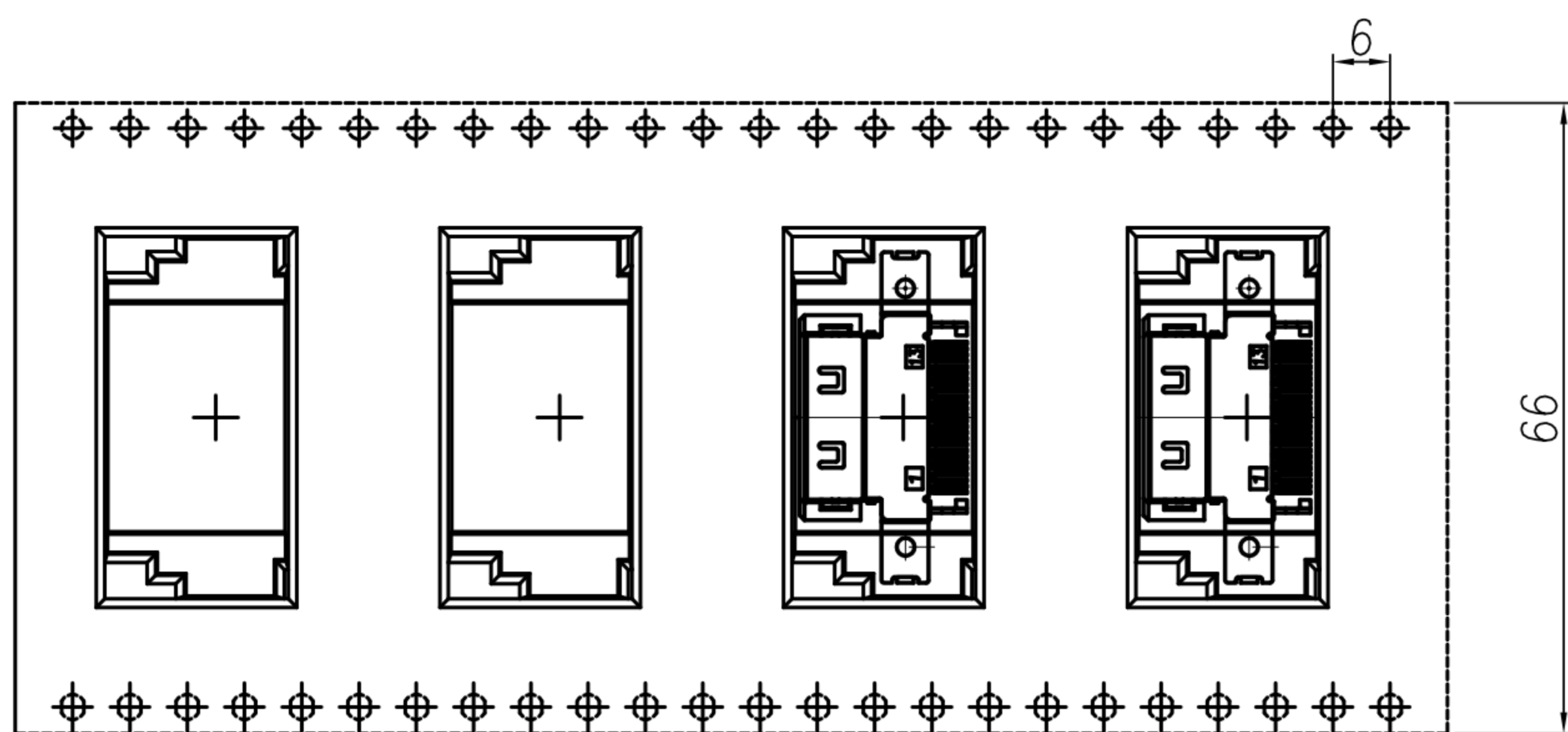
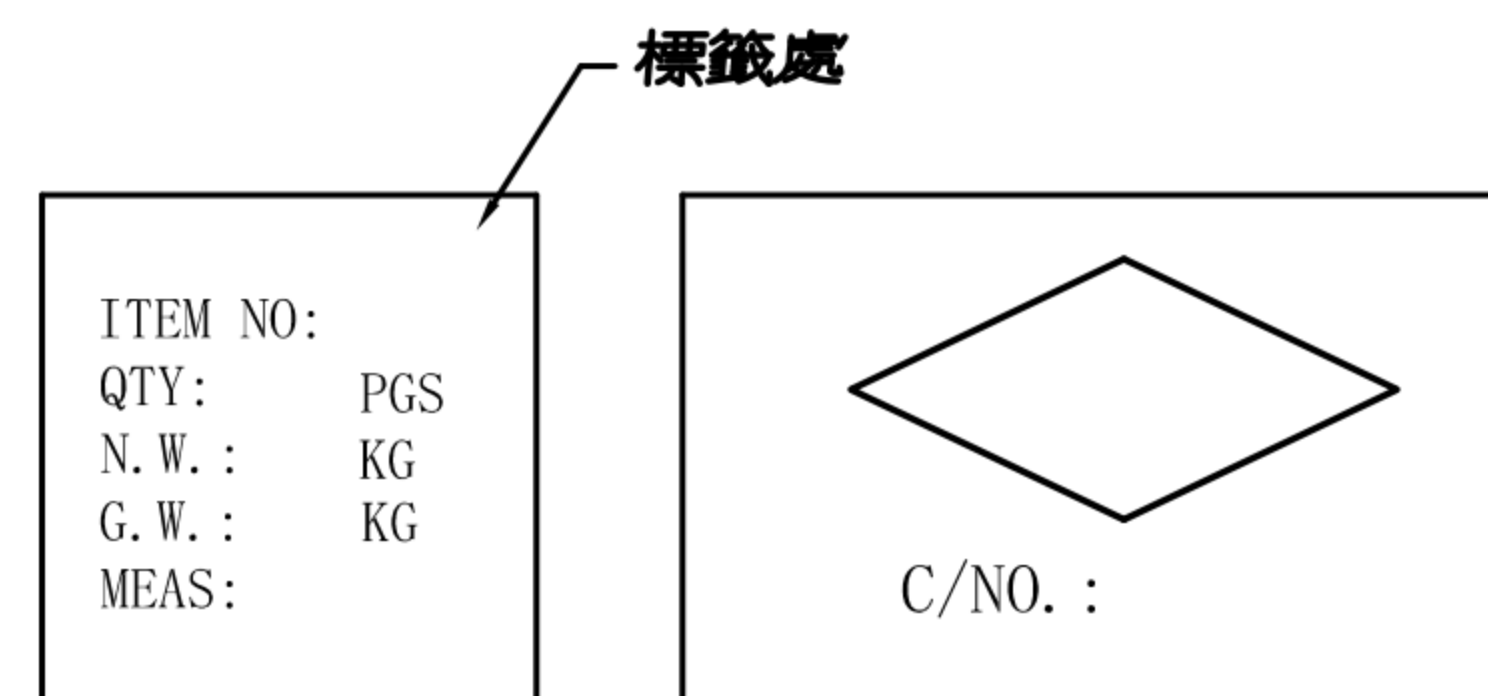
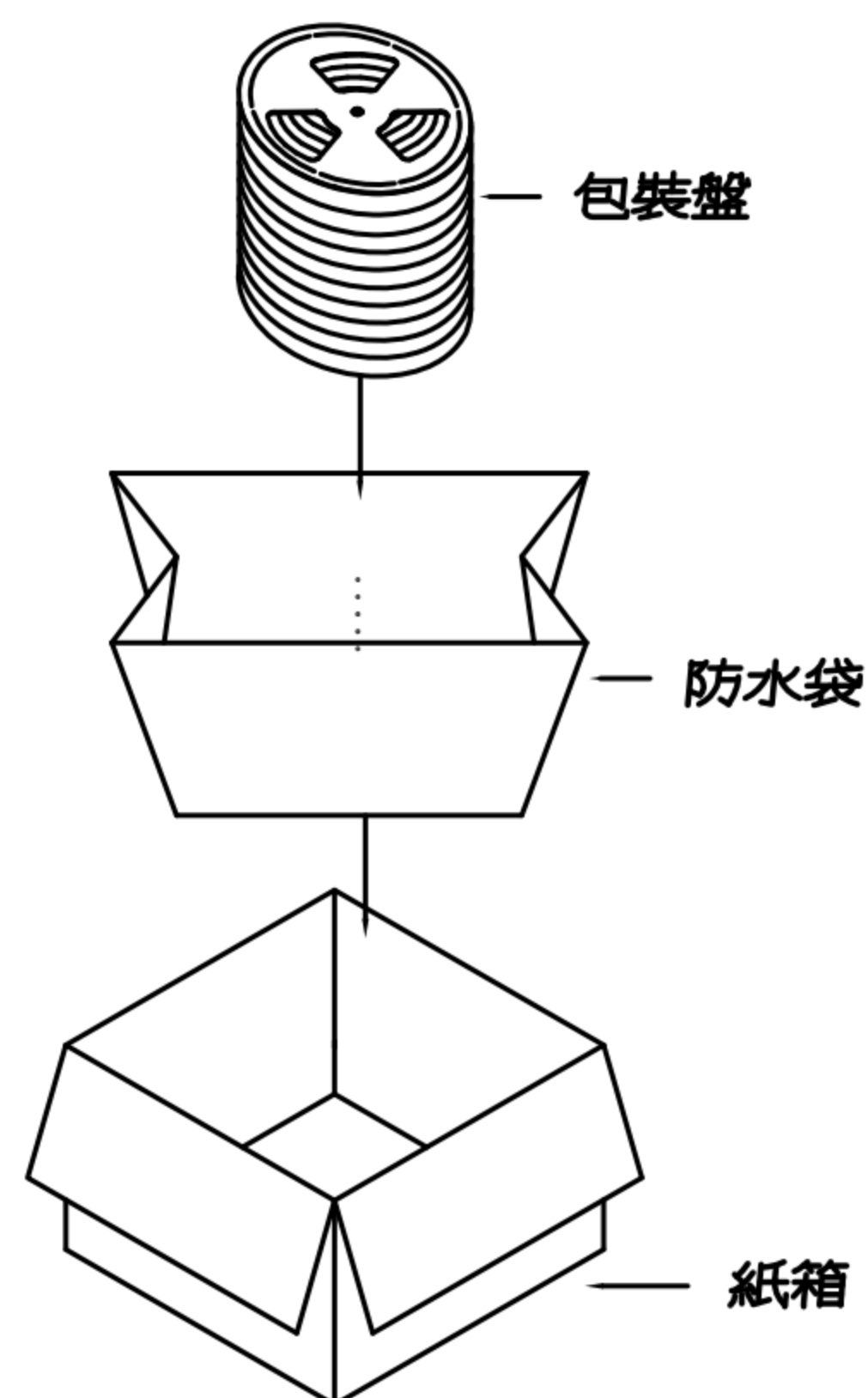
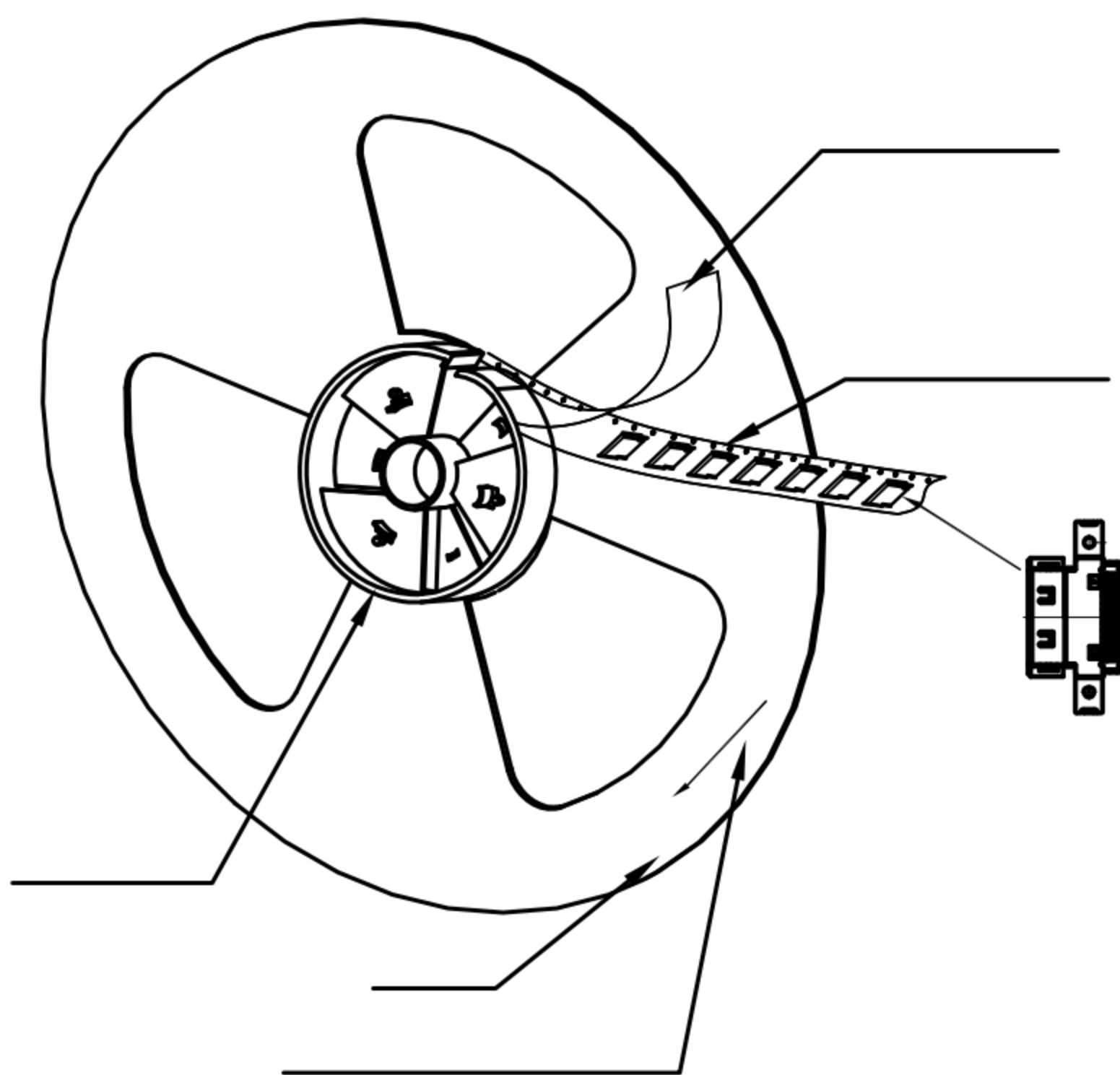
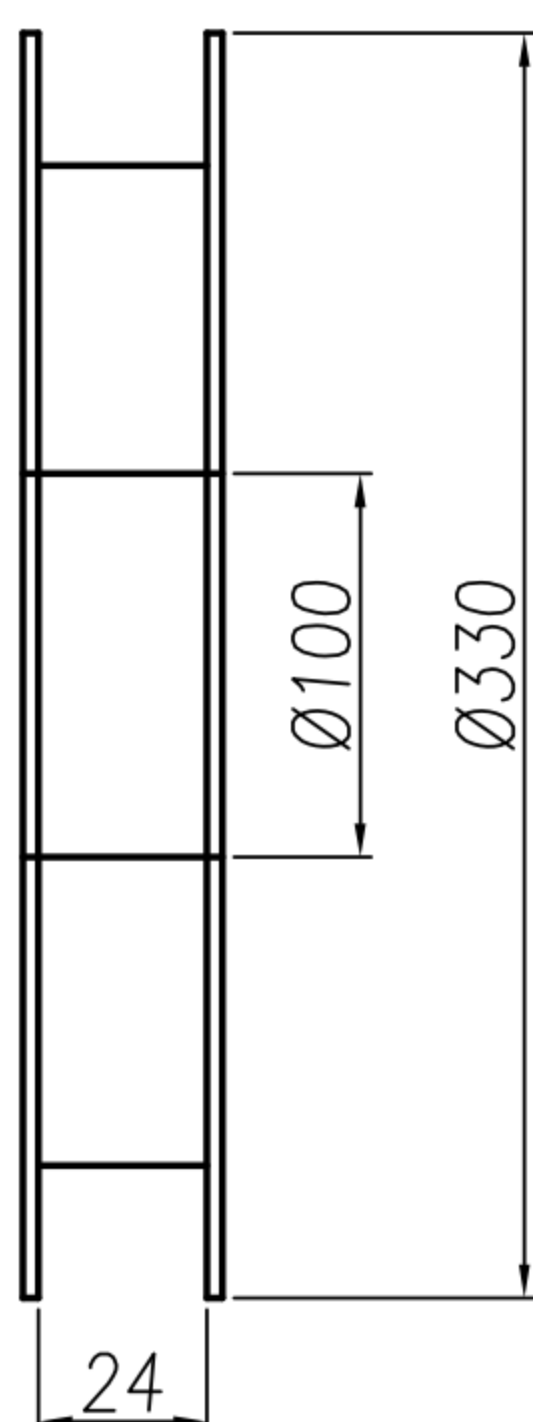

NOTE:

- 若有未裝滿之零數箱,必須以緩衝材塞滿.
- 在搬運過程中要輕拿輕放.
- 載運輸中不可堆放過多,不可有重壓現象.
- 在裝滿產品後,必須空留帶前和帶後15格以上,然後用紙膠布貼上.
- 上帶在貼下帶時必須平整,且黏貼處不要出現氣泡.

DRAWN	Yeh Chou	APP'D	Ku Chou	UNIT	mm	TOLERANCE			TITLE	PCMCIA 26PIN B TYPE TAPE & REEL			SHEET	2
CHK'D	Emily Suen			SCALE	1:1				PART NO.	PK-1-PC260501	DWG NO.	QC6426	VERSION	A

CUSTOMER DRAWING

REV.	DESCRIPTION	APPVL. BY	DATE	ECN NO.
A	RELEASE	Fido Weng	28/11/13'	
B				
C				

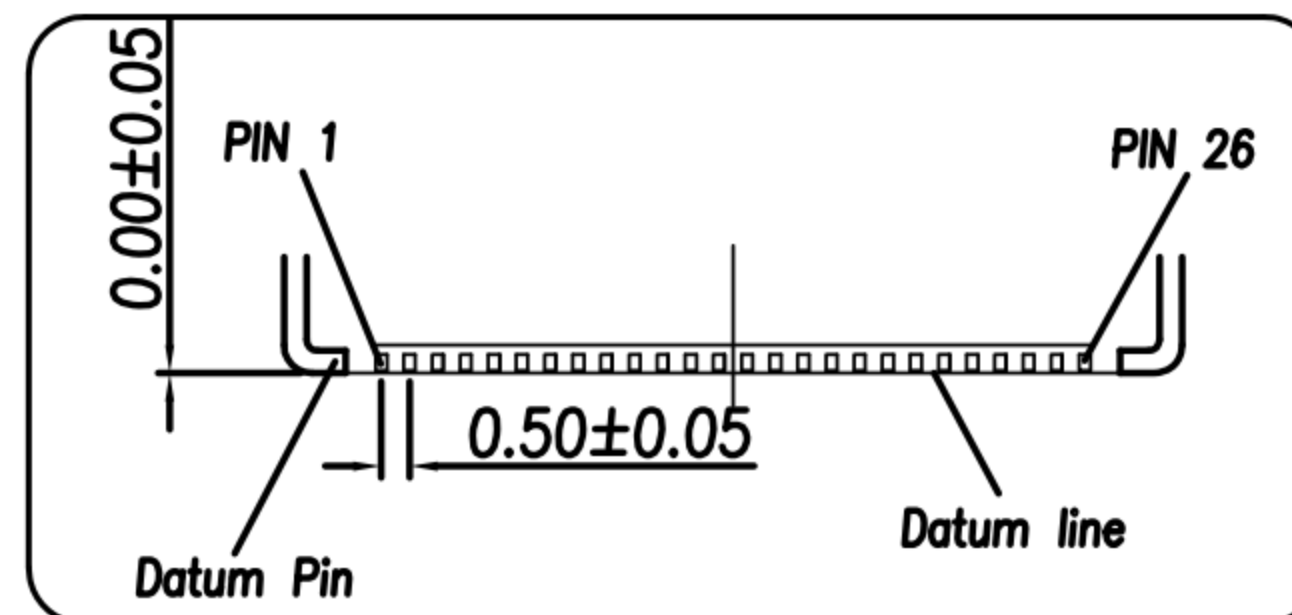
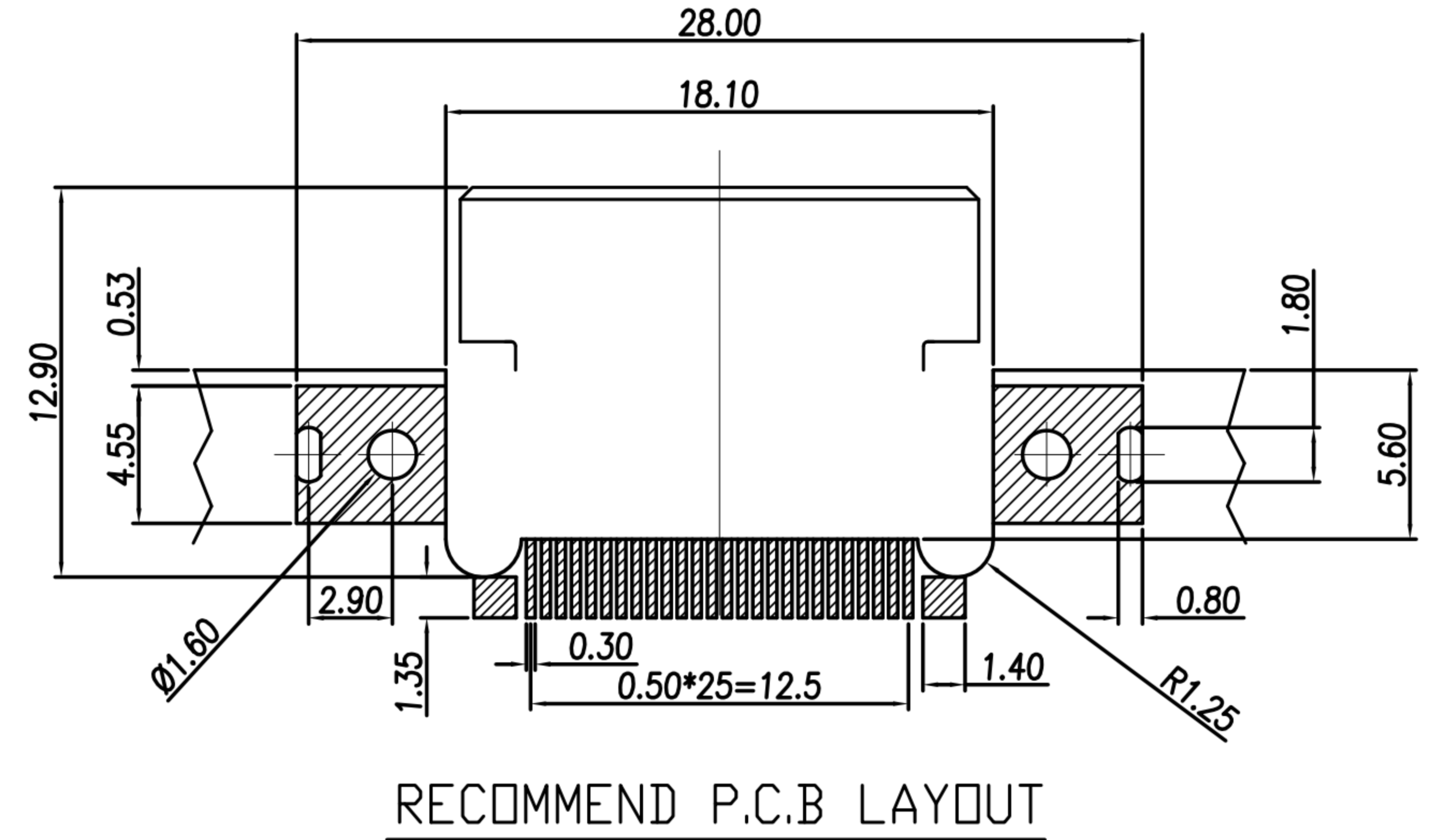
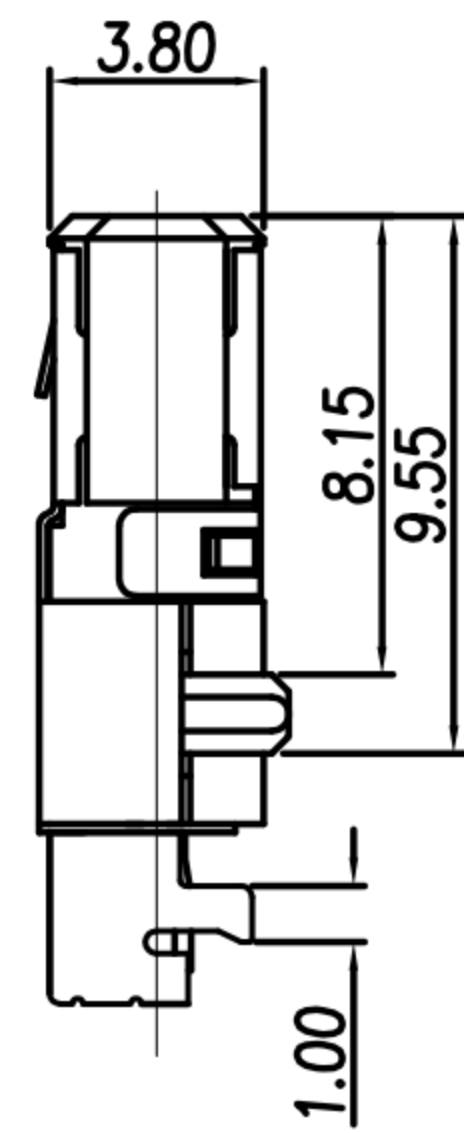
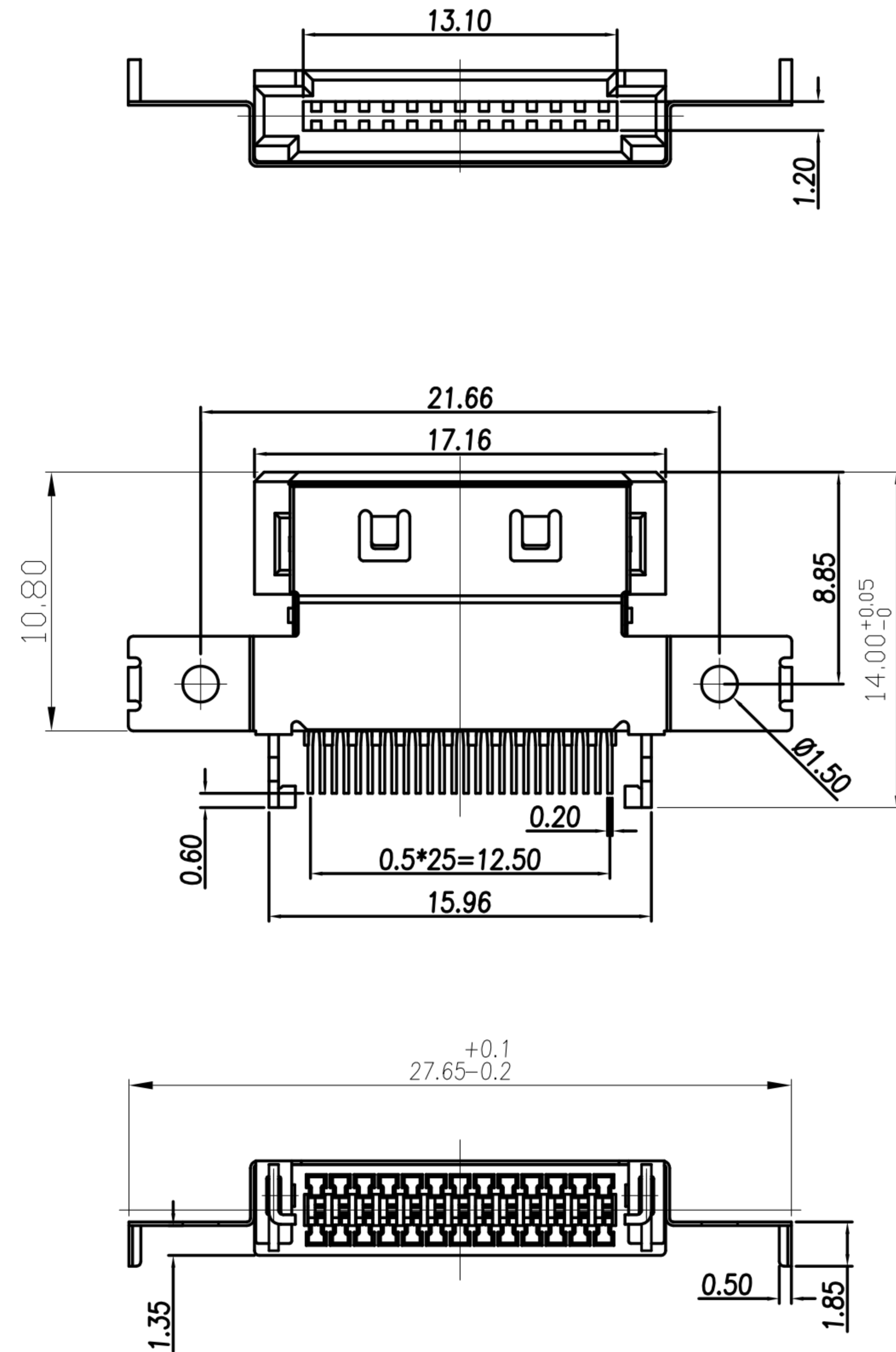

1. MATERIAL :
 - 1-1. HOUSING : LCP UL94V-0 ; COLOR : BLACK
 - 1-2. CONTACT : PHOSPHOR BRONZE
 - 1-3. SHELL-1 : PHOSPHOR BRONZE
 - 1-4. SHELL-2 : PHOSPHOR BRONZE
 - 1-5. GROUND : BRASS.
2. FINISH :
 - 2-1. CONTACT :
 - CONTACT AREA : GOLD 30u"
 - SOLDER AREA : BRIGHT TIN
 - UNDER PLATE : NICKEL
 - 2-2. SHELL : MATTE TIN
 - UNDER PLATE : NICKEL
 - 2-3. GROUND : BRIGHT TIN
 - UNDER PLATE : NICKEL

DRAWN	Yeh Chou	APP'D	Ku Chou	UNIT	mm	TOLERANCE		广东科斯达电子科技有限公司 GUANG DONG KE SI DA ELECTRONIC TECHNOLOGY CO., LTD.	TITLE	PCMCIA 26PIN B TYPE			SHEET	1/2
CHK'D	Emily Suen			SCALE	1:1	.x ±0.20 .xx ±0.10 .xxx ±0.05 .xxxx ±0.03 ANGULA ±1°			PART NO.	PC-26M4-04-01	DWG NO.	QC6426	VERSION	A