

CUSTOMER DRAWING

REV.	DESCRIPTION	APPROVED BY	DATE	ECN NO.
△A	RELEASE	Yeh Chou	2017/xx/xx	
△B				
△C				
△D				

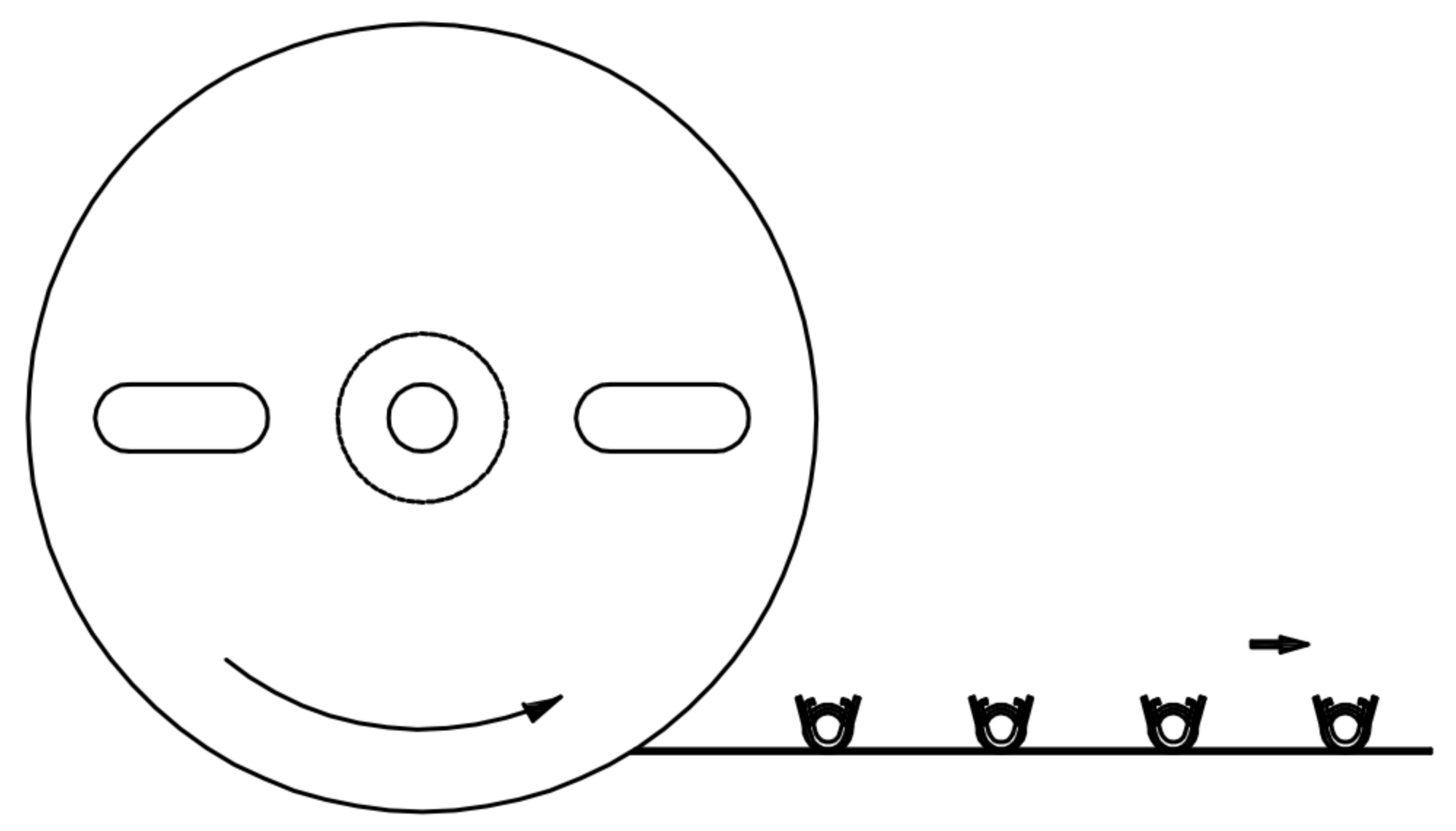
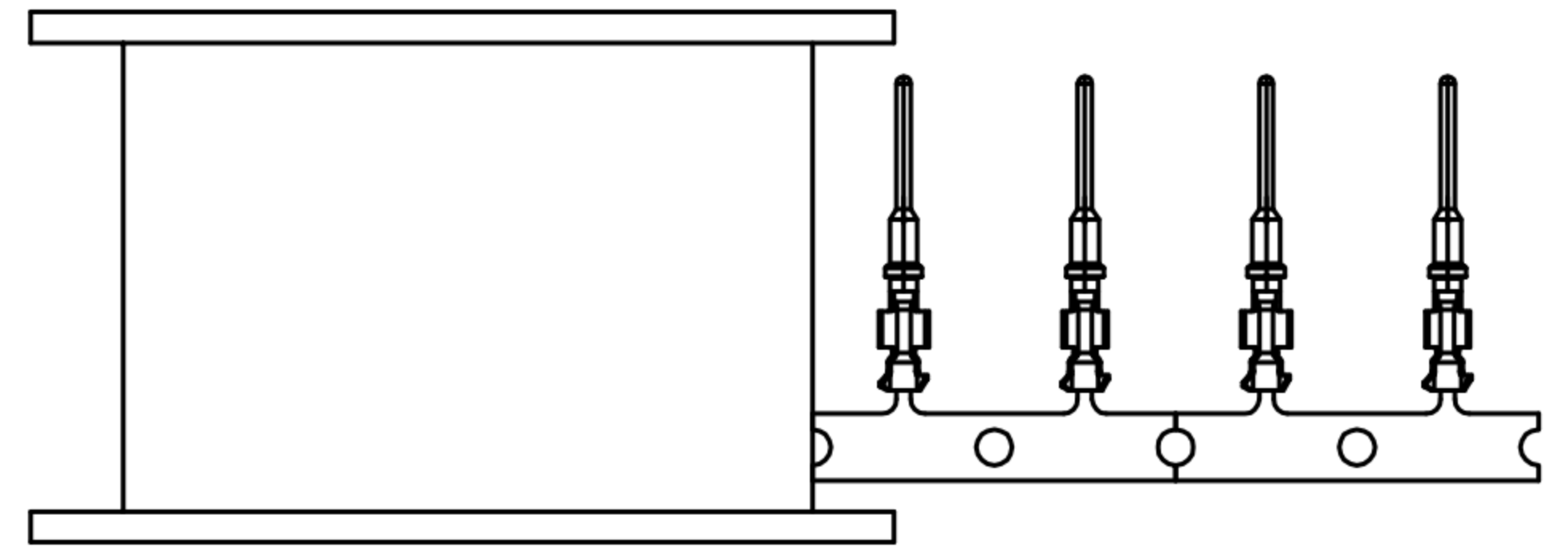
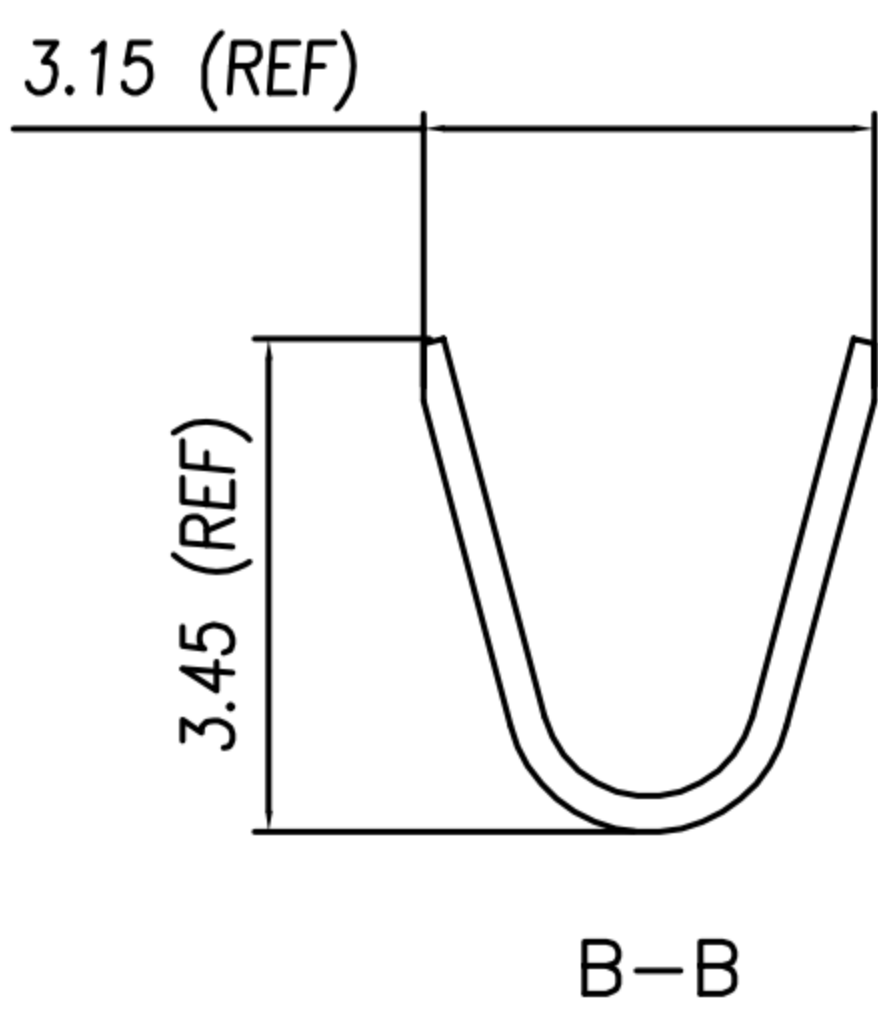
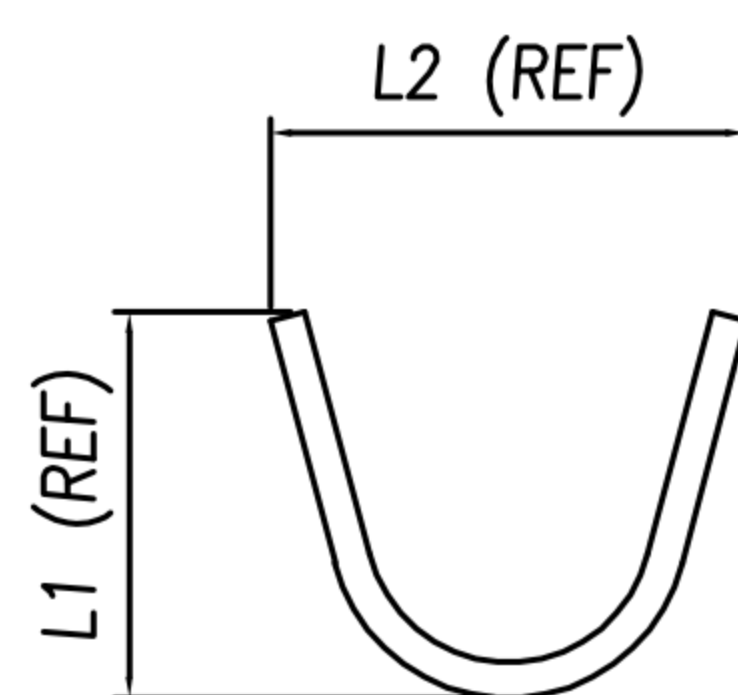
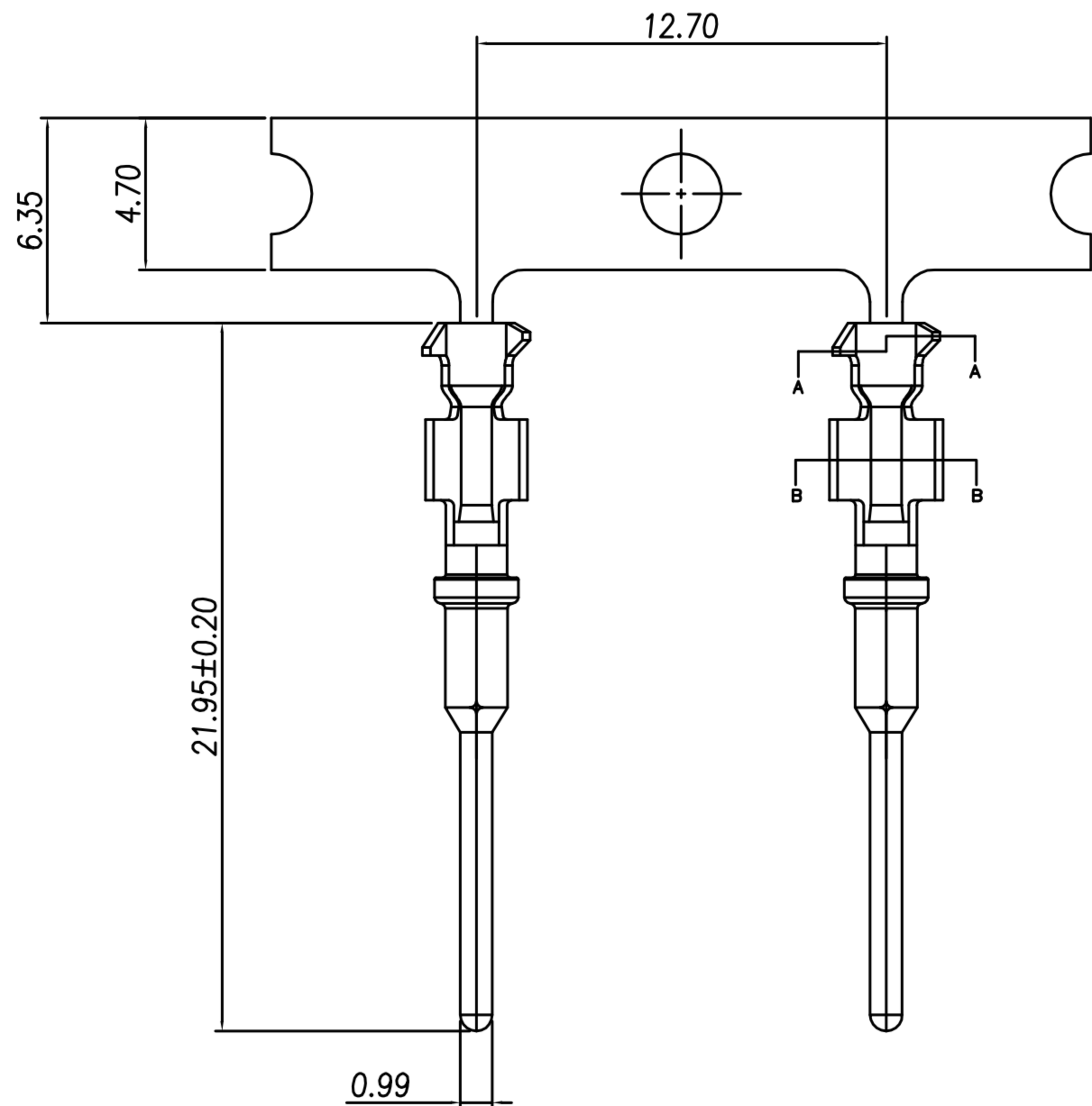

PULL OUT DIRECTION

TABLE A

OY-WP01132-00	2.70	3.33	防水頭12PIN (M) 端子(Crimp PIN 14~18AWG)	MATTE TIN 80u"~100u"
OY-WP01133-00	2.70	3.33	防水頭12PIN (M) 端子(Crimp PIN 14~18AWG)	NICKEL 80u"~100u"
OY-WP11132-00	2.70	3.33	防水頭12PIN (M) 端子(Crimp PIN 14~18AWG)(素)	素材
OY-WP01130-00	3.35	4.40	防水頭12PIN (M) 端子(Crimp PIN 12~14AWG)	MATTE TIN 80u"~100u"
OY-WP01131-00	3.35	4.40	防水頭12PIN (M) 端子(Crimp PIN 12~14AWG)	NICKEL 80u"~100u"
OY-WP11130-00	3.35	4.40	防水頭12PIN (M) 端子(Crimp PIN 12~14AWG)(素)	素材
P/N	L1	L2	TITLE	FINISH

- MATERIAL :
  - 1-1. CONTACT : PHOSPHOR BRONZE
  - 1-2. SHELL : STAINLESS STEEL
- FINISH :
  - 2-1. CONTACT : SEE TABLE A

DRAWN	Yeh Chou	APPVL		UNIT	mm	TOLERANCE		广东科斯达电子科技有限公司 GUANG DONG KE SI DA ELECTRONIC TECHNOLOGY CO., LTD.	TITLE	SEE TABLE A			SHEET	1
CHK'D				SCALE	1:1	.x ±0.20 .xx ±0.10 .xxx ±0.05 .xxxx ±0.03 ANGULA ±1°			PART NO.	SEE TABLE A	DWG NO.	QC8191	VERSION	A