

# CUSTOMER DRAWING

REV.	DESCRIPTION	APPL. BY	DATE	ECN NO.
A	RELEASE	FIDO WENG	30/03/09"	S-09018
B	新增材質	FIDO WENG	28/04/09"	ECN09074
C				

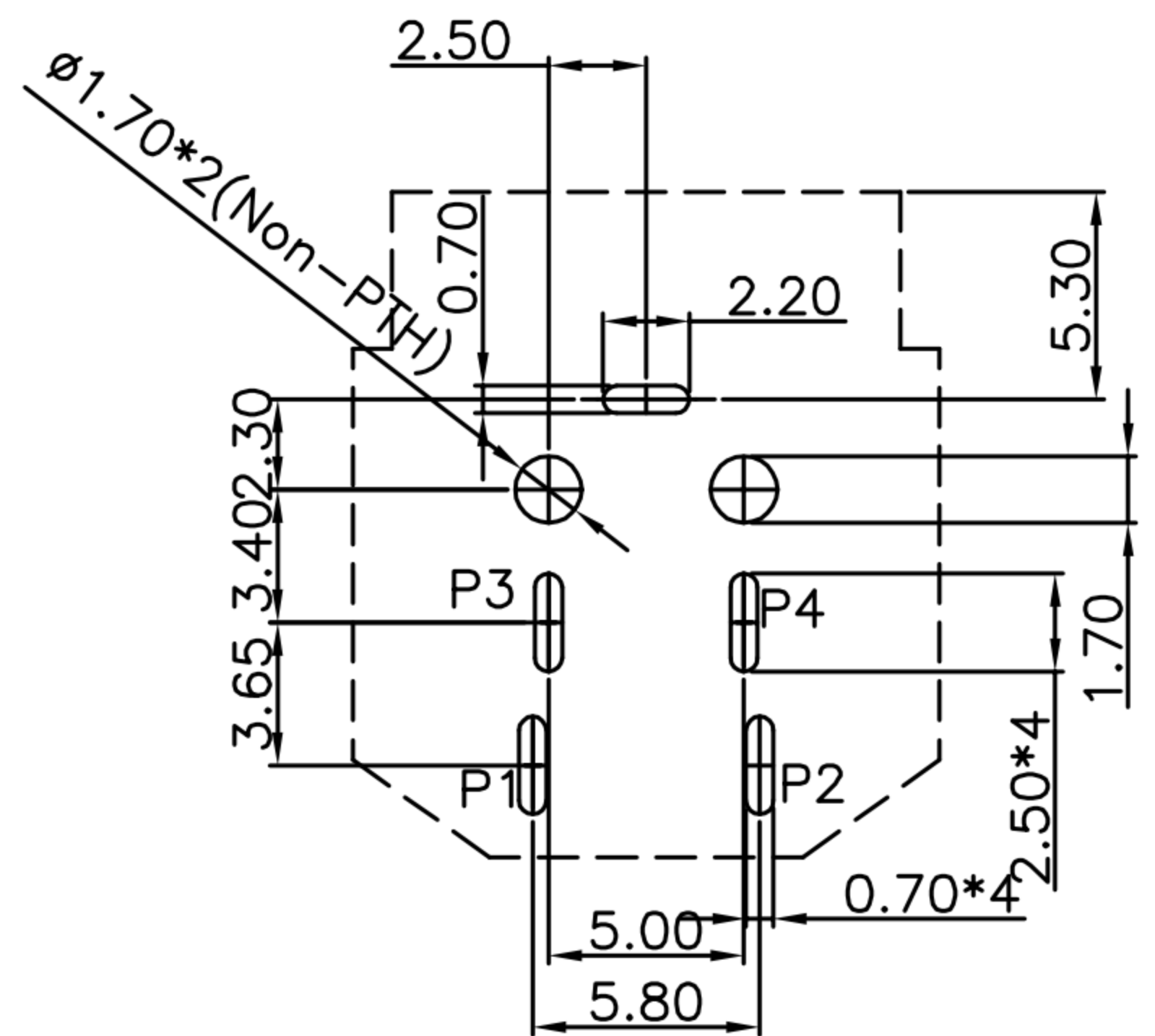
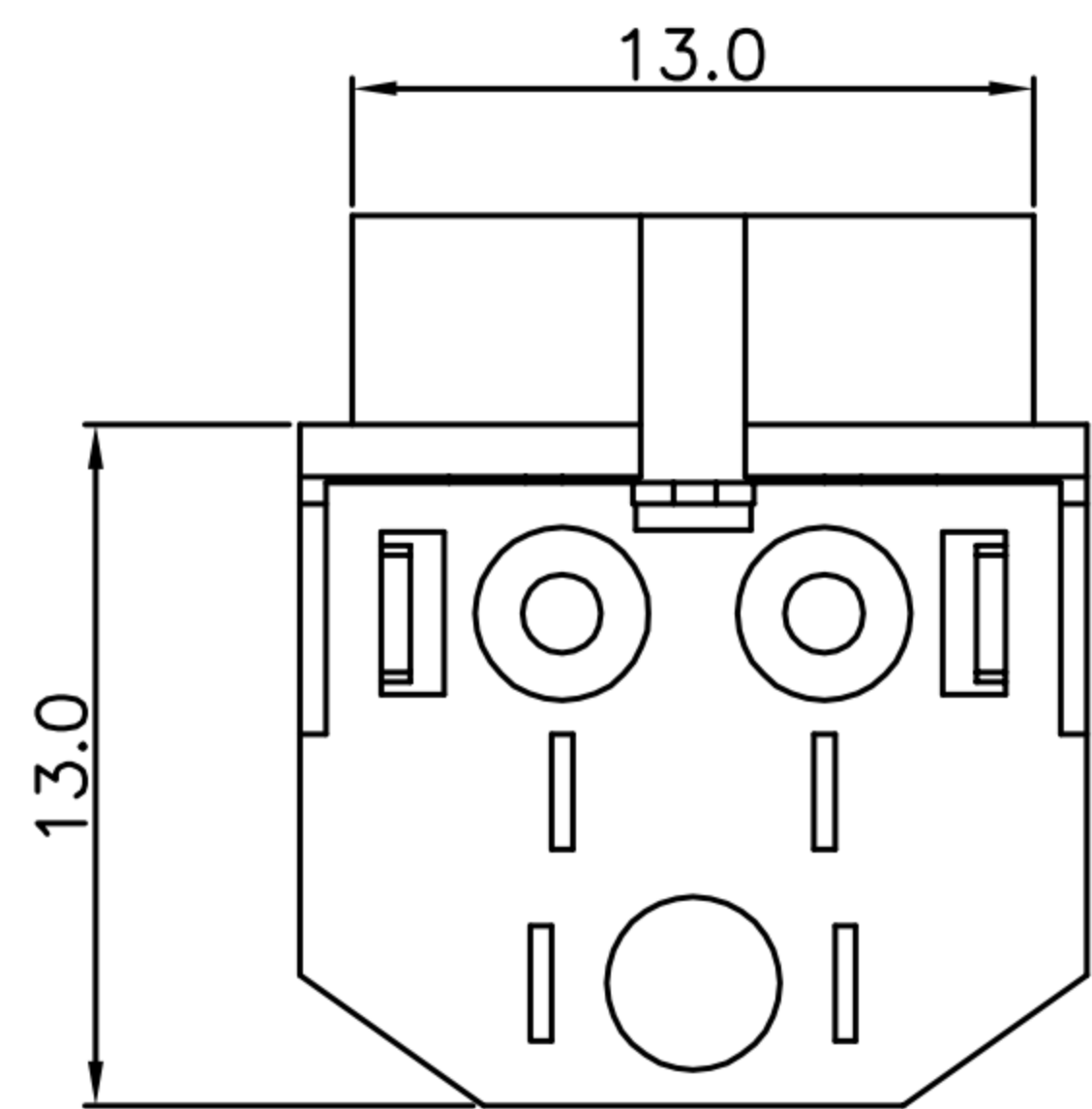
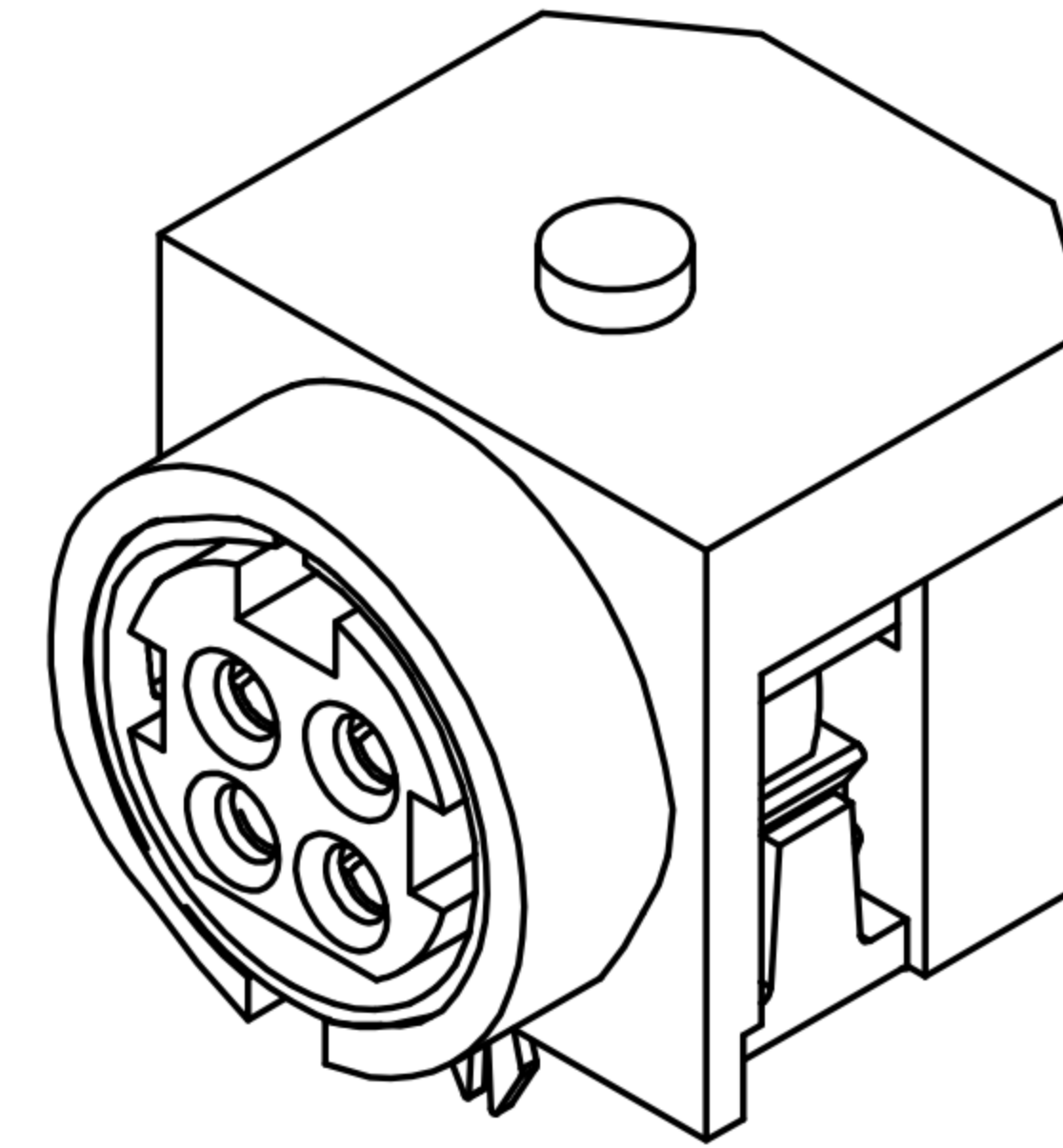
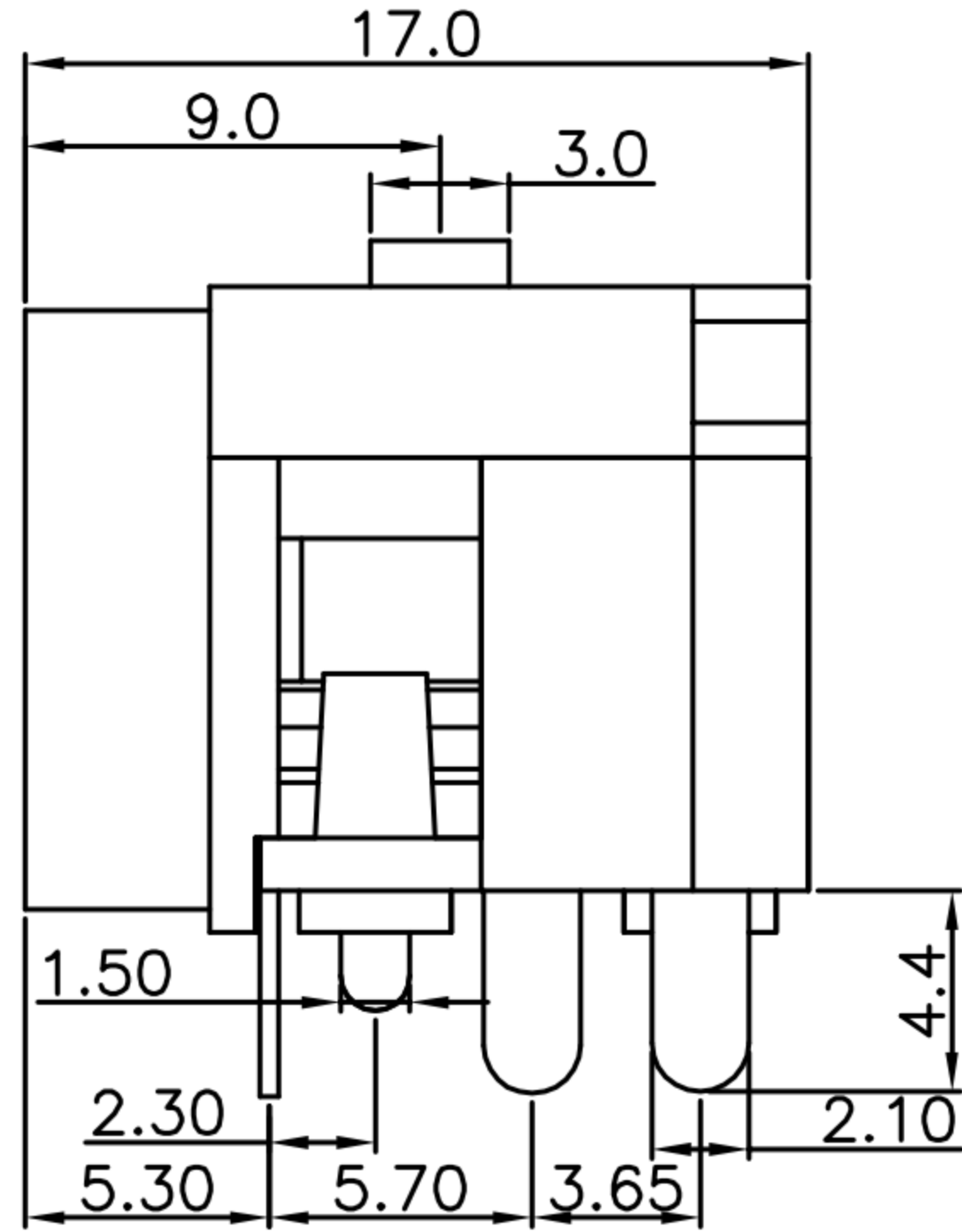
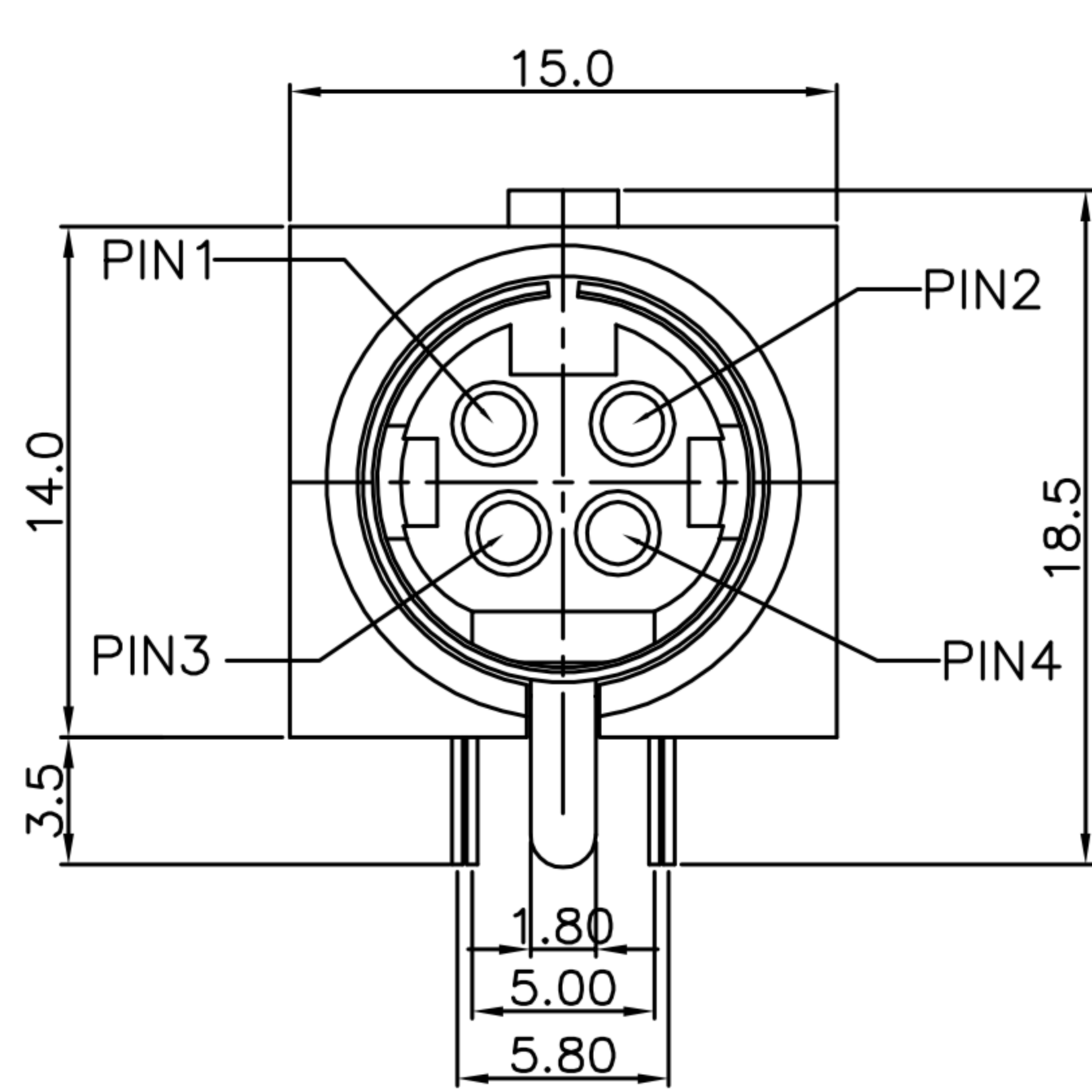

HOLE LAYOUT(BOTTOM VIEW)

- MATERIAL :
  - HOUSING : PBT
  - CONTACT : PHOSPHOR BRONZE
  - GROUND : BRASS
  - SHELL : SPCC
- FINISH :
  - CONTACT : SILVER PLATING
  - GROUND : NICKEL PLATED OVER ALL
- ELETRICAL SPECICATION :
  - RATED CURRENT FOR 3P : PIN1&2 7.5A  
PIN3 1A  
RATED CURRENT FOR 4P : 7.5A FOR ALL PIN
  - RATED VOLTAGE : 20V DC
  - CONTACT RESISTANCE : 30mΩ
  - INSULATION RESISTANCE : 50MΩ Min. at 250V DC
  - DIELECTRIC STRENGTH : 250V AC / 1 minute
  - INSERTION FORCE : 45N max.
  - WITHDRAWAL FORCE : 9N TO 30N
  - DURABILITY TEST : 1000 Cycles
- ENVIRONMENTAL :
  - OPERATION TEMPERATURE : -20 °C~85°C

DRAWN	賴鴻志	APP'D	Emily Suen	UNIT	mm	TOLERANCE		广东科斯达电子科技有限公司 GUANG DONG KE SI DA ELECTRONIC TECHNOLOGY CO., LTD.	TITLE	PowerDin 4(F) 4-PIN DIP (PBT)			SHEET	
CHK'D	Emily Suen	SCALE	1:1	ANGULA	±1°	PART NO.			PD-04F3-02-01	DWG NO.	QC9486	VERSION	B	