

# CUSTOMER DRAWING

REV.	DESCRIPTION	APPVL. BY	DATE	ECN NO.
A	RELEASE	Fideo Weng	16/03/'09	
B	增加打點	Emily Suen	02/05/12"	ECN12007
C	尺寸改變	Emily Suen	14/02/17"	ECN17001

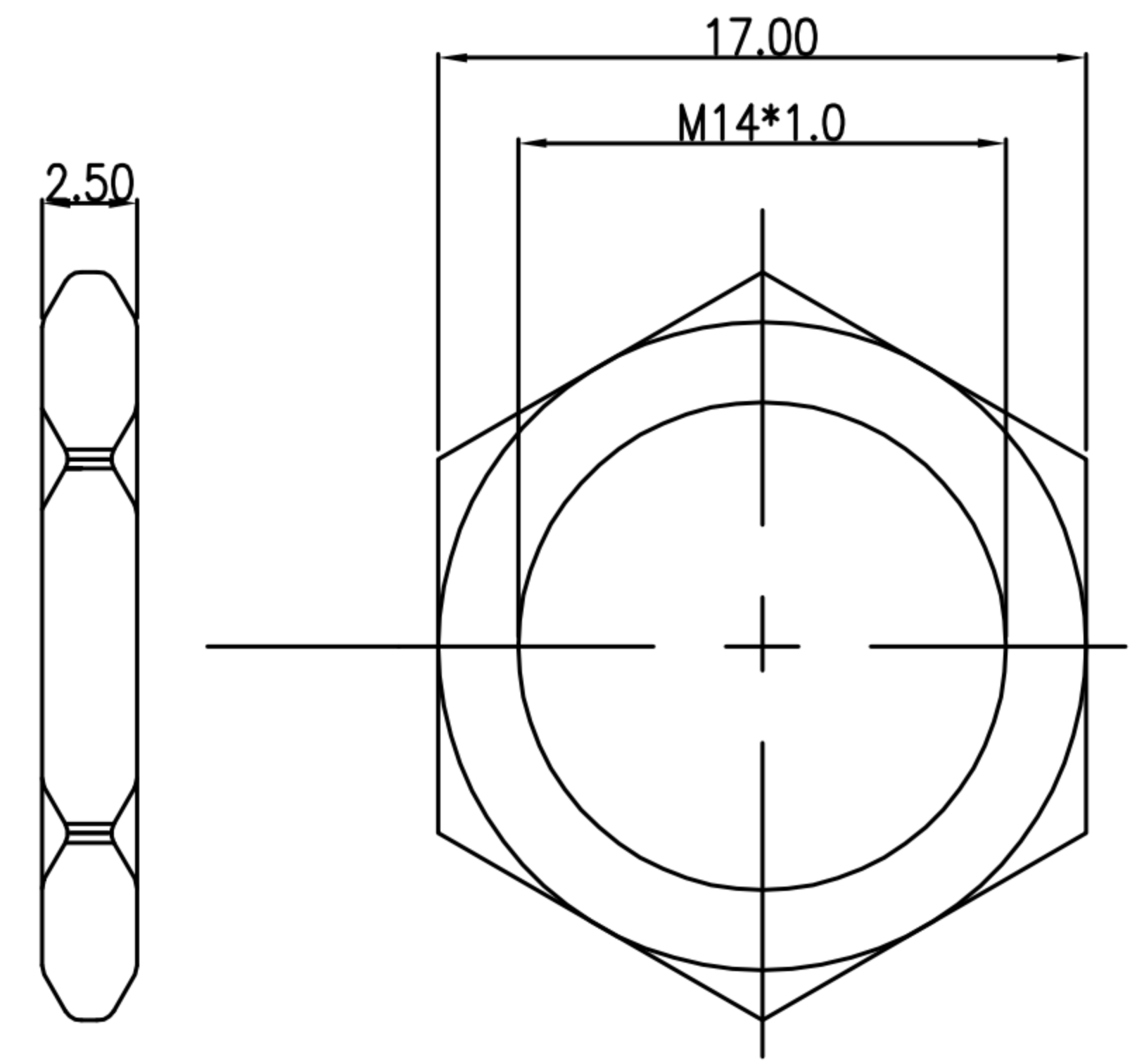
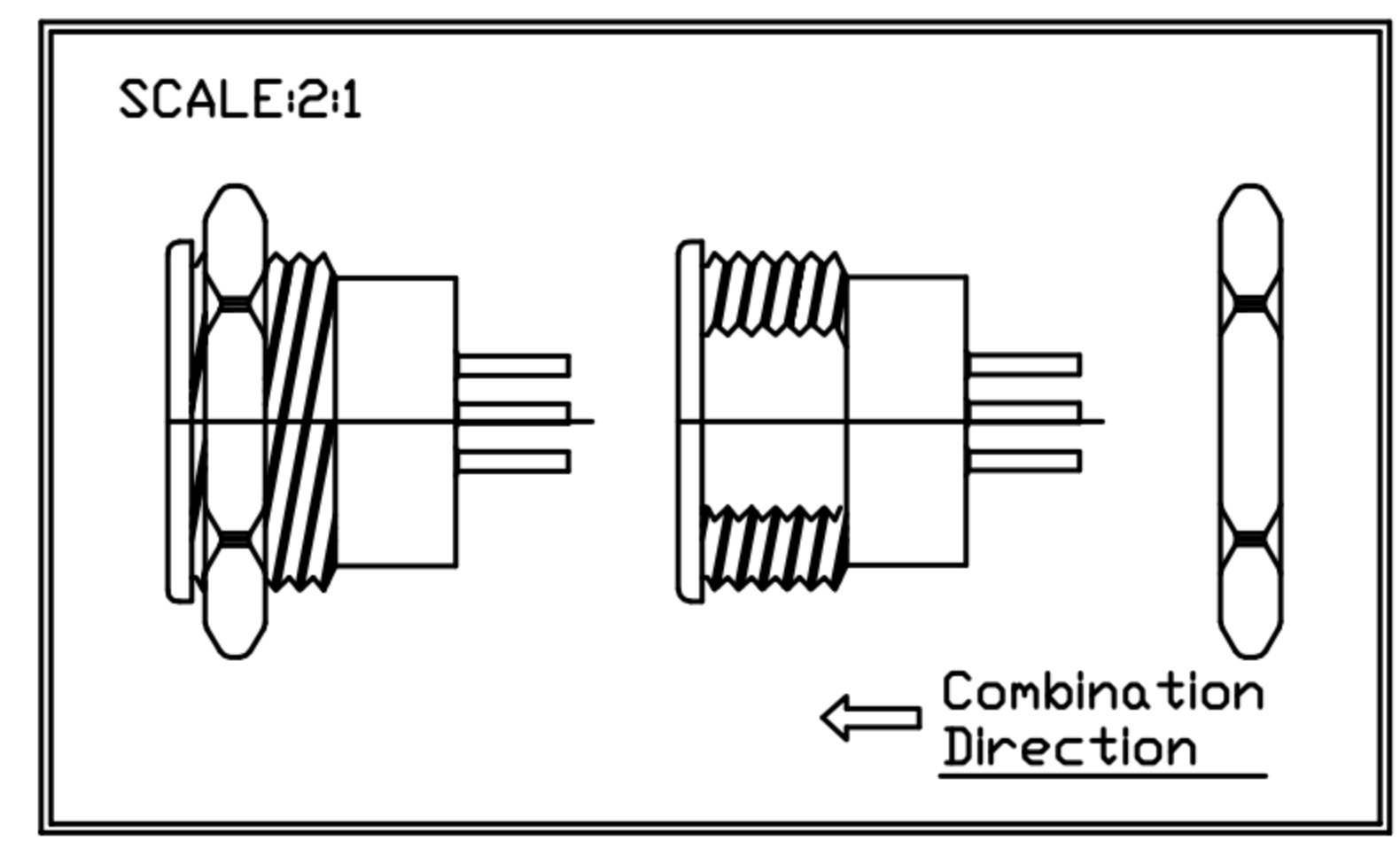
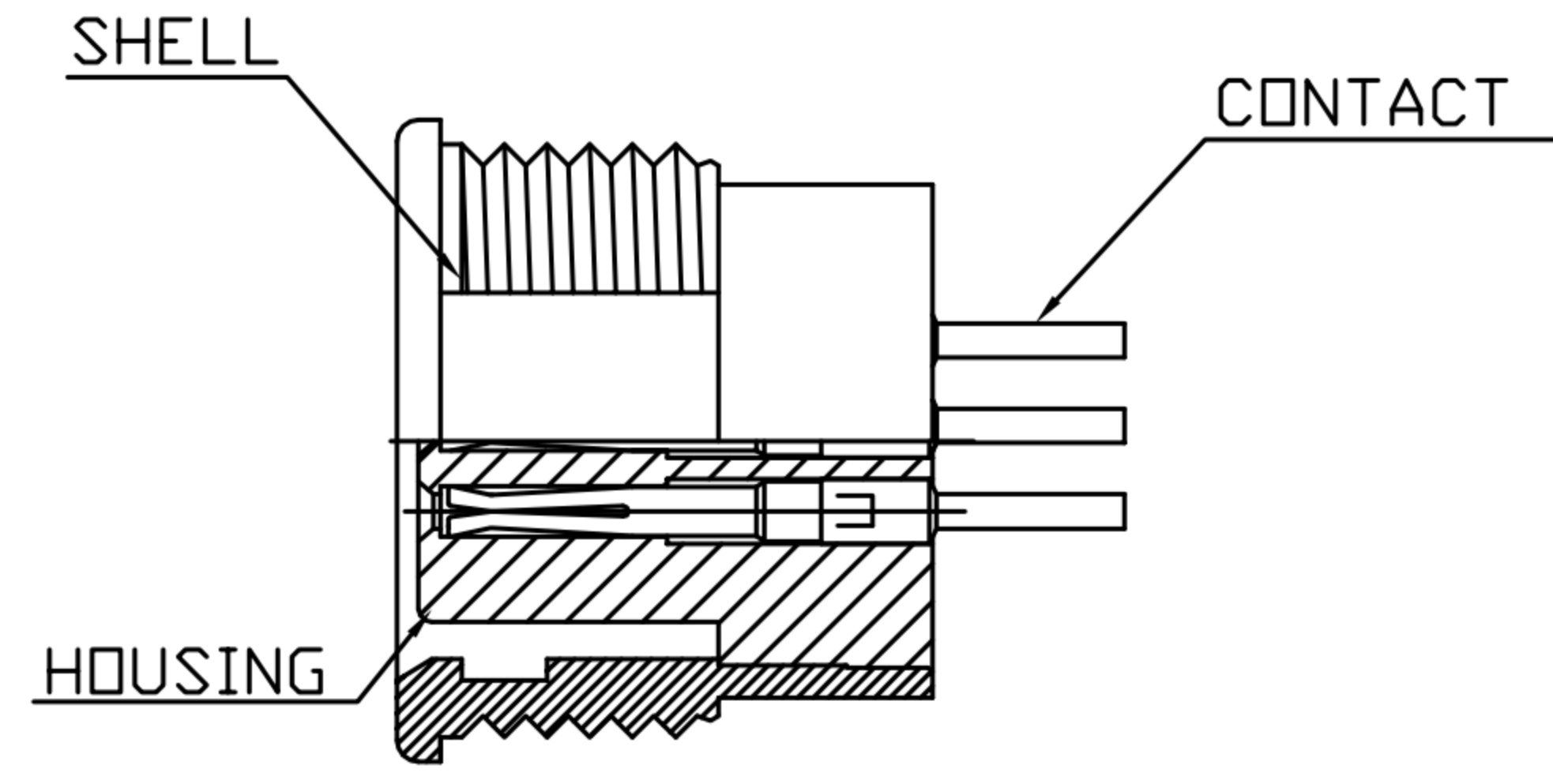
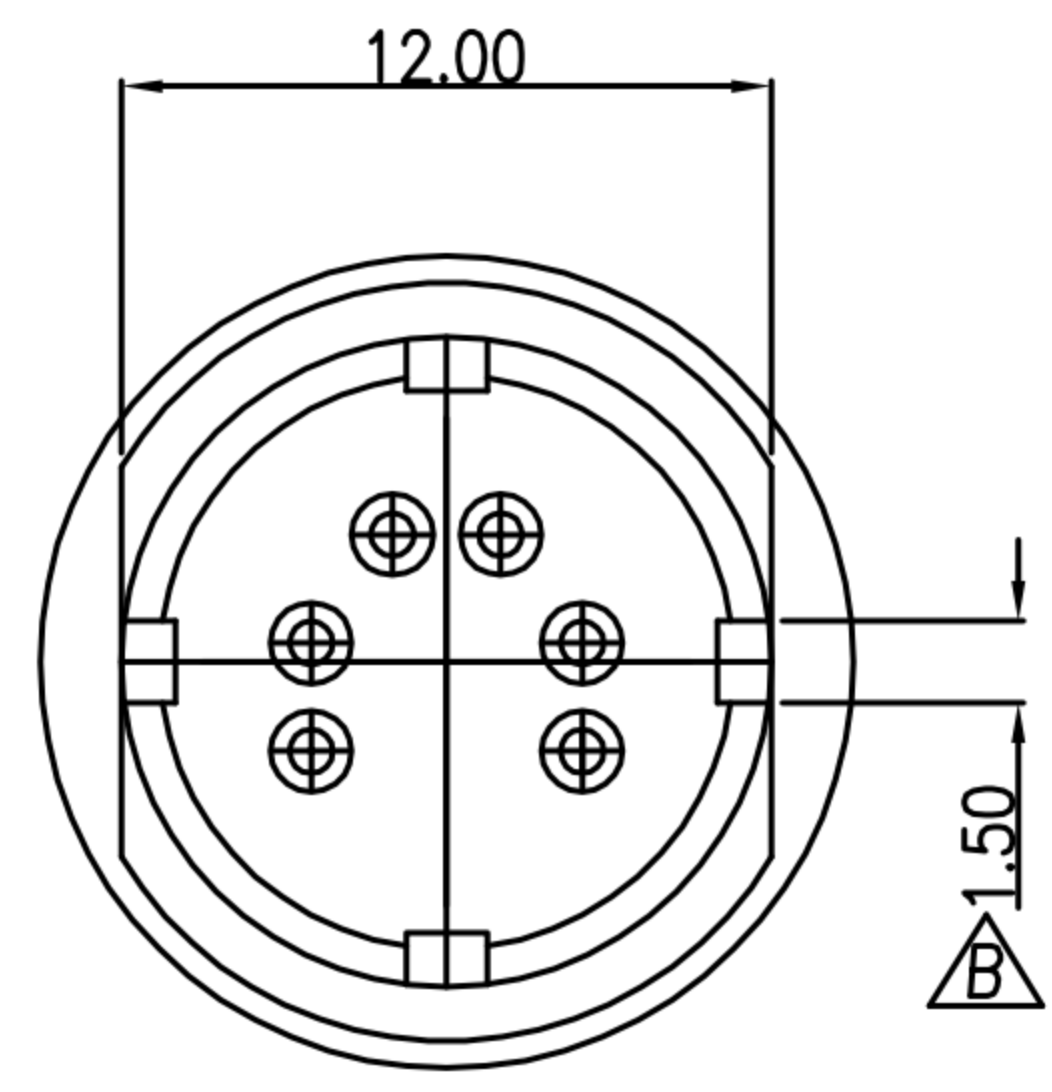
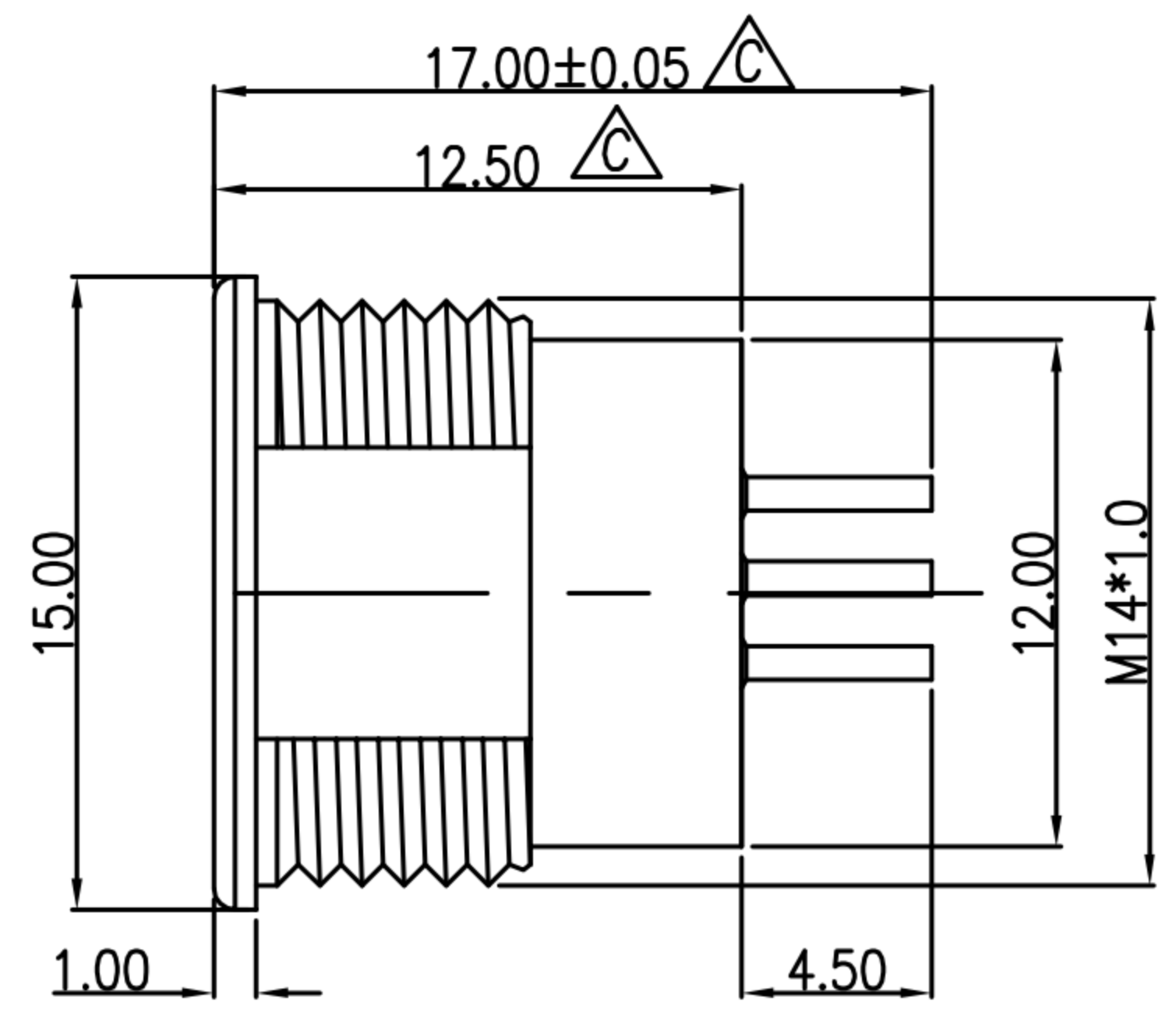
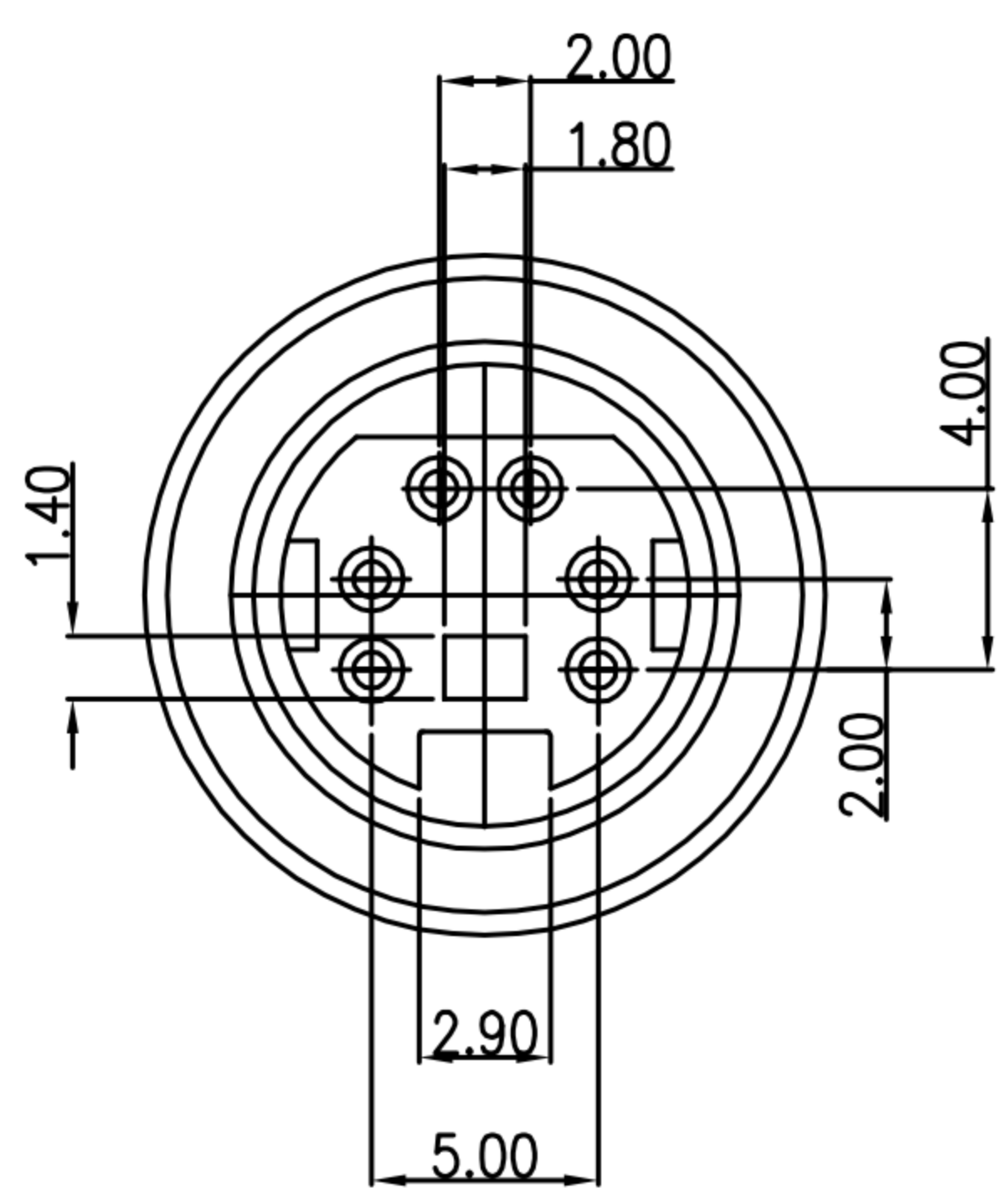

NUT

- MATERIAL :
  - 1-1. HOUSING : PBT UL94V-0 ; COLOR : BLACK
  - 1-2. CONTACT : PHOSPHOR BRONZE
  - 1-3. SHELL : BRASS
  - 1-4. NUT : BRASS
- FINISH :
  - 2-1. CONTACT : GOLD FLASH PLATED OVER NICKEL
  - 2-2. SHELL : NICKEL PLATED
  - 2-3. NUT : NICKEL PLATED
- ELETRICAL SPECICATION :
  - 3-1. Rated current : 1A
  - 3-2. Rated voltage : 60V
- Environmental :
  - 4-1. Operation Temperature : -20℃~85℃

DRAW	Ku Chou	APPVL	Emily Suen	UNIT	mm	TOLERANCE		广东科斯达电子科技有限公司 GUANG DONG KE SI DA ELECTRONIC TECHNOLOGY CO., LTD.	TITLE	POWER DIN 6(F)LOCK TYPE(ON BOARD)			SHEET
CHECK	Emily Suen			SCALE	1:1				PART NO.	PD-06F5-01	DWG NO.	QC1654	VERSION