

CUSTOMER DRAWING

REV.	DESCRIPTION	APPVL. BY	DATE	ECN NO.
E	增加生產注意事項	Fido Weng	26/05/08'	ECN09086
F	取消生產注意事項	Fido Weng	12/10/09'	
G	MODIFY DRAWING & PCB LAYOUT	Fido Weng	10/12/10'	

步驟一:

- 將成品一一放入包裝盤內,依同一方向置入.
- 包裝方式,如圖所示.
- 一個包裝盤700pcs.

步驟二:

- 一個紙箱可以裝6個包裝盤.
- 每盤700pcs,每箱7000pcs.
- 將包裝盤放入防水袋中,包裝完後再封箱.

步驟三:

- 用膠帶將紙箱封實.
- 將標籤貼於紙箱上.
- 外箱尺寸:35cm*35cm*31cm

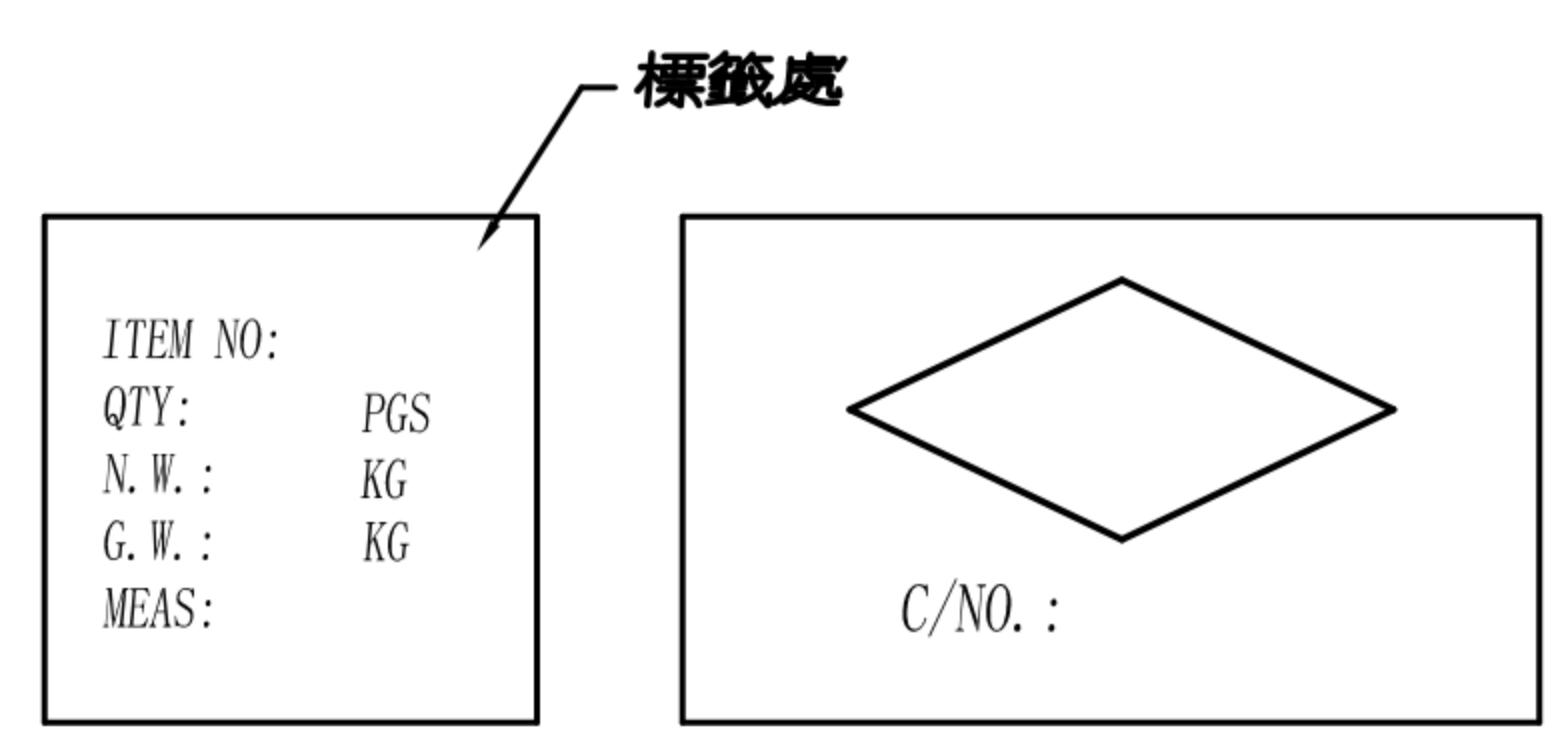
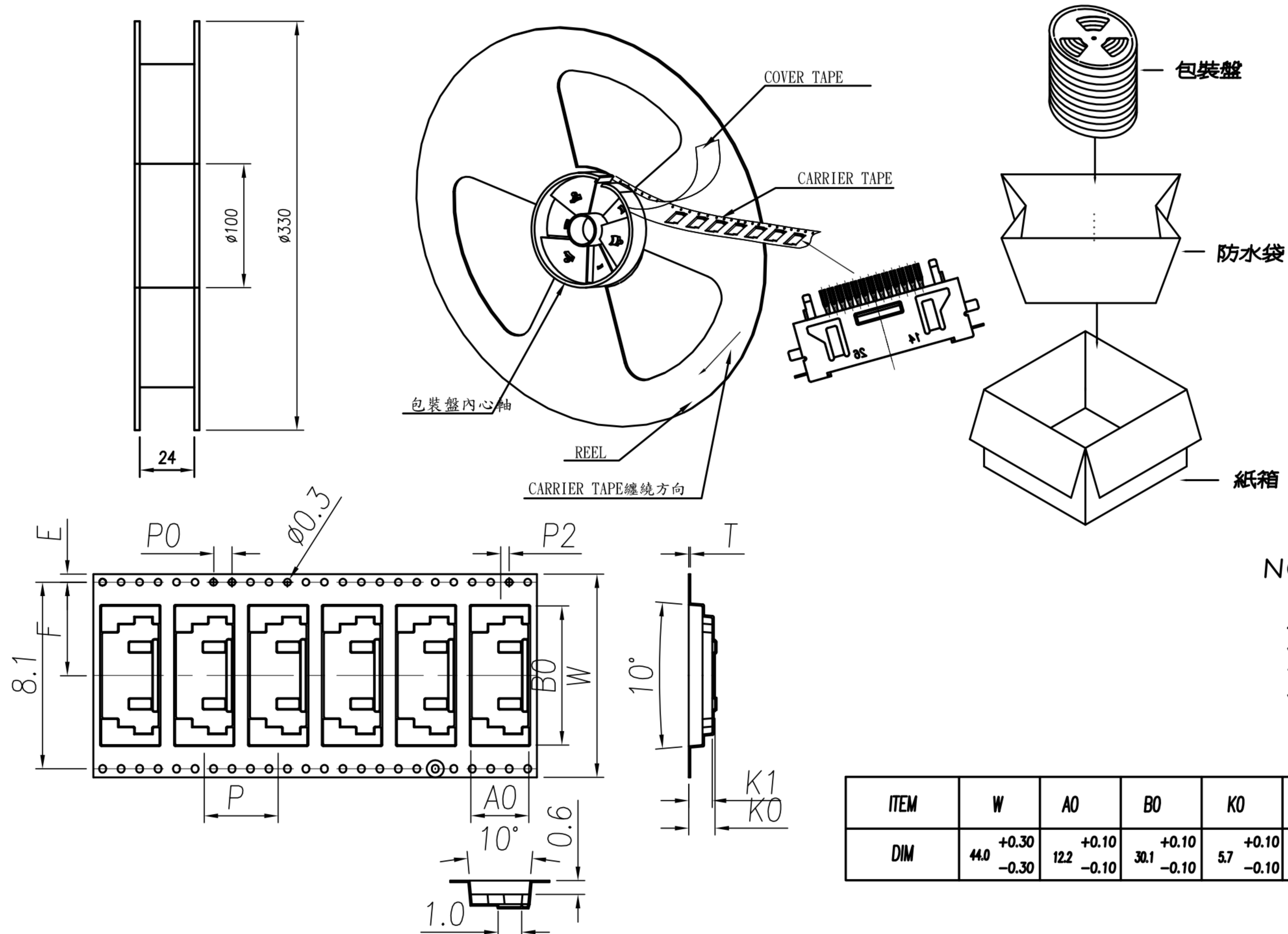

- NOTE:
- 若有未裝滿之零數箱,必須以緩衝材塞滿.
 - 在搬運過程中要輕拿輕放.
 - 載運輸中不可堆放過多,不可有重壓現象.
 - 在裝滿產品後,必須空留帶前和帶後15格以上,然後用紙膠布貼上.
 - 上帶在貼下帶時必須平整,且黏貼處不要出現氣泡.

ITEM	W	AO	BO	K0	K1	P	F	E	DO	D1	P0	P2	T
DIM	44.0 +0.30 -0.30	122 +0.10 -0.10	30.1 +0.10 -0.10	5.7 +0.10 -0.10	5.1 +0.10 -0.10	16.0 +0.10 -0.10	20.2 +0.10 -0.10	1.75 +0.10 -0.10	1.5 +0.10 -0.00	0.00 +0.25 -0.00	4.0 +0.10 -0.10	2.0 +0.10 -0.10	0.4 +0.05 -0.05

DRAWN	Ku Chou	APP'D	Fido Weng	UNIT	mm	TOLERANCE		TITLE	PCMCIA 26PIN A TYPE (F)			SHEET	2
CHK'D	Emily Suen			SCALE	1:1	.x ±0.20 .xx ±0.10 .xxx ±0.05 .xxxx ±0.03 ANGULA ±1°		PART NO.	TABLE A	DWG NO.	QC0475	VERSION	G

广东科斯达电子科技有限公司
GUANG DONG KE SI DA ELECTRONIC TECHNOLOGY CO., LTD.

