

This document is the property of Nian-Yeong Corporation and is delivered on the express condition that it is not to be disclosed, reproduced or used, in whole or in part, for manufacture or sale by anyone other than Nian-Yeong Corporation without its prior consent, and that no right is granted to disclose or to use any information in this document.

CUSTOMER DRAWING

REV.	DESCRIPTION	APPVL. BY	DATE	ECN NO.
△A				
△B				
△C				

步驟一:

- 將成品一一放入包裝盤內,依同一方向置入.
- 包裝方式,如圖所示.
- 包裝數量如下: 9P 96pcs/盤
15P 80pcs/盤
25P 64pcs/盤
- 層疊10盤後,在以膠膜固定

步驟二:

- 一個紙箱可以裝7個包裝盤.
- 每箱7盤,數量如下: 9P 672pcs/箱
15P 560pcs/箱
25P 448pcs/箱
- 將包裝盤放紙箱中,後封箱.

步驟三:

- 用膠帶將紙箱封實.
- 將標籤貼於紙箱上.

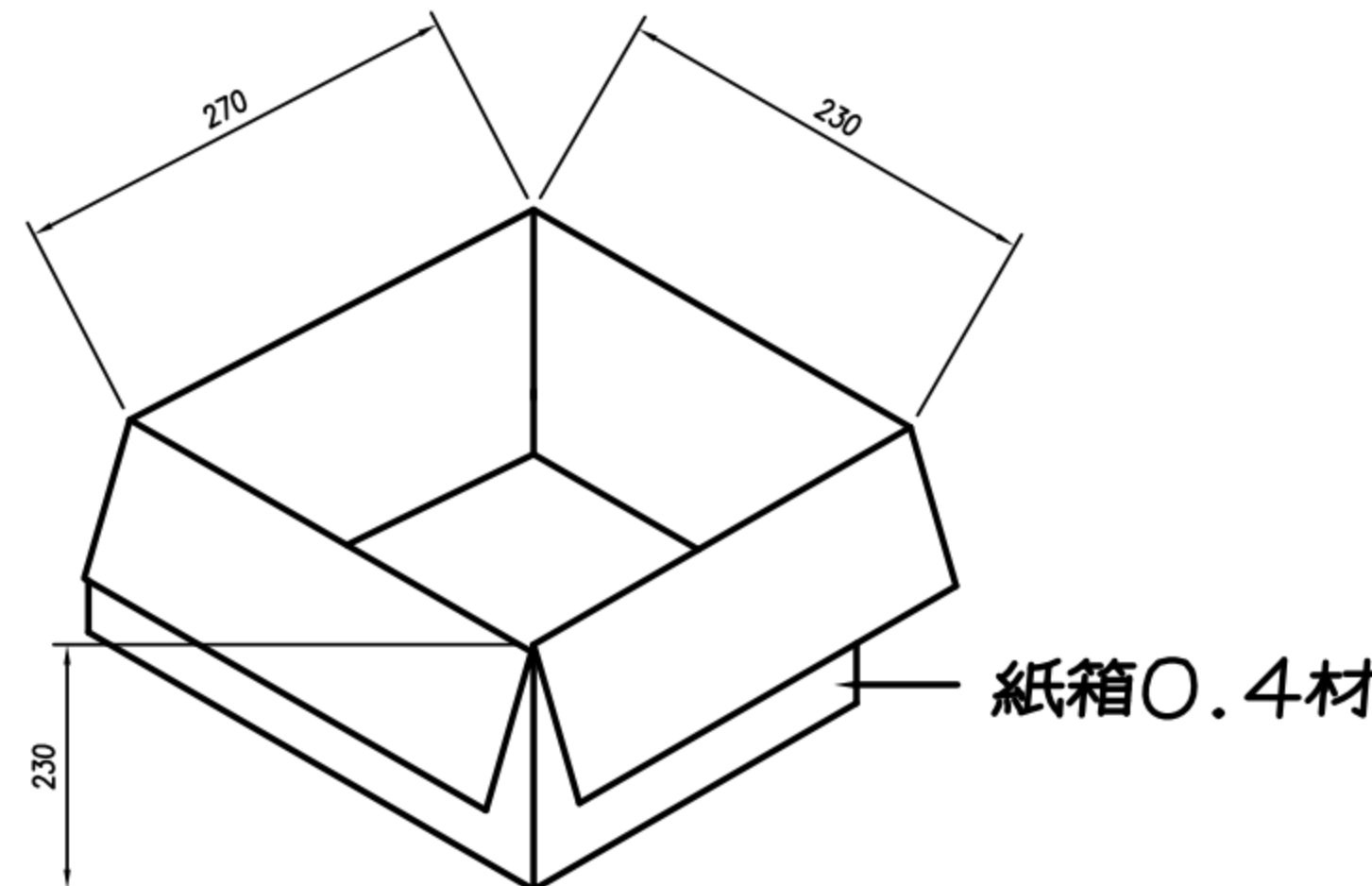
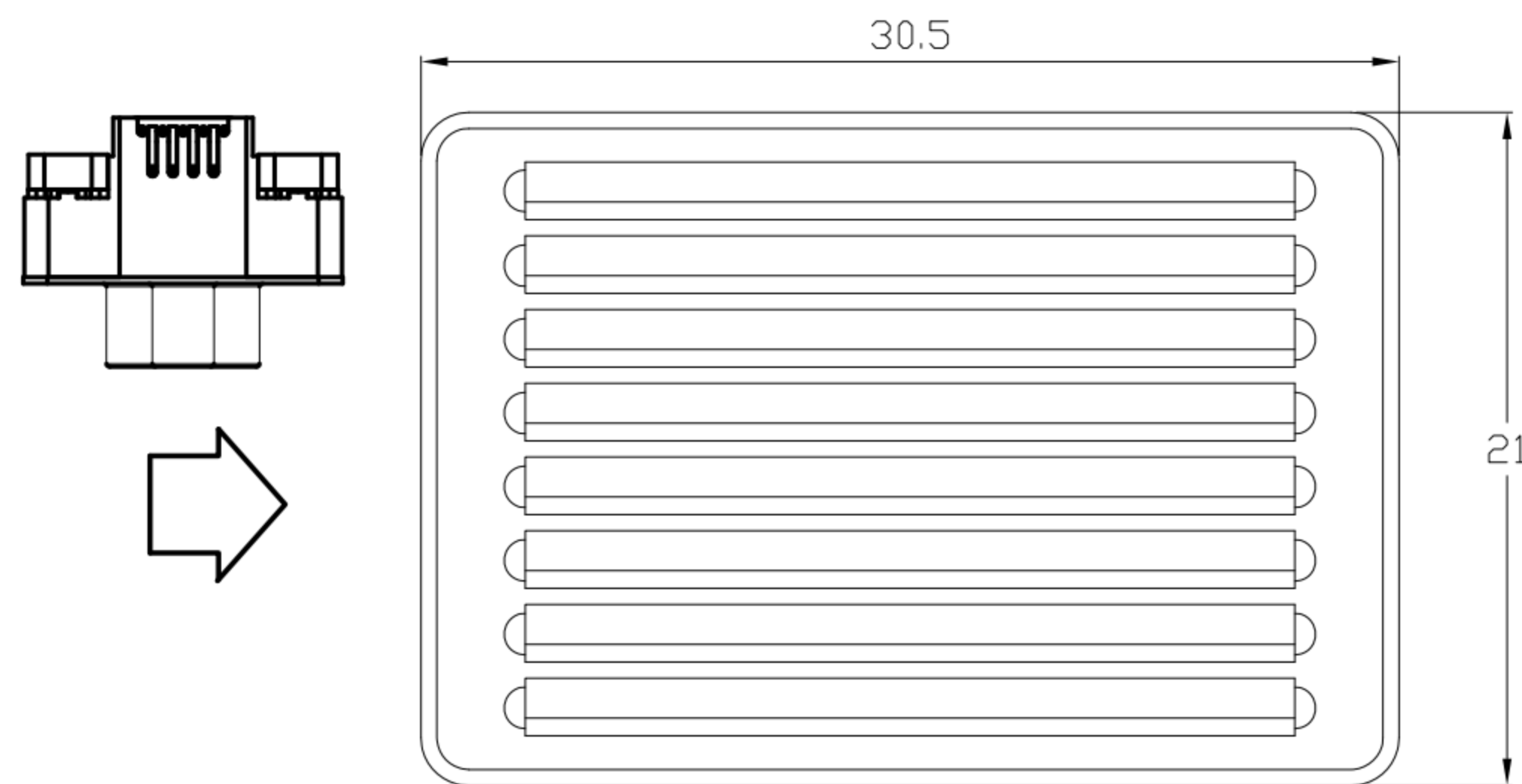

ITEM NO:
QTY: PGS
N. W. : KG
G. W. : KG
MEAS:

標籤處

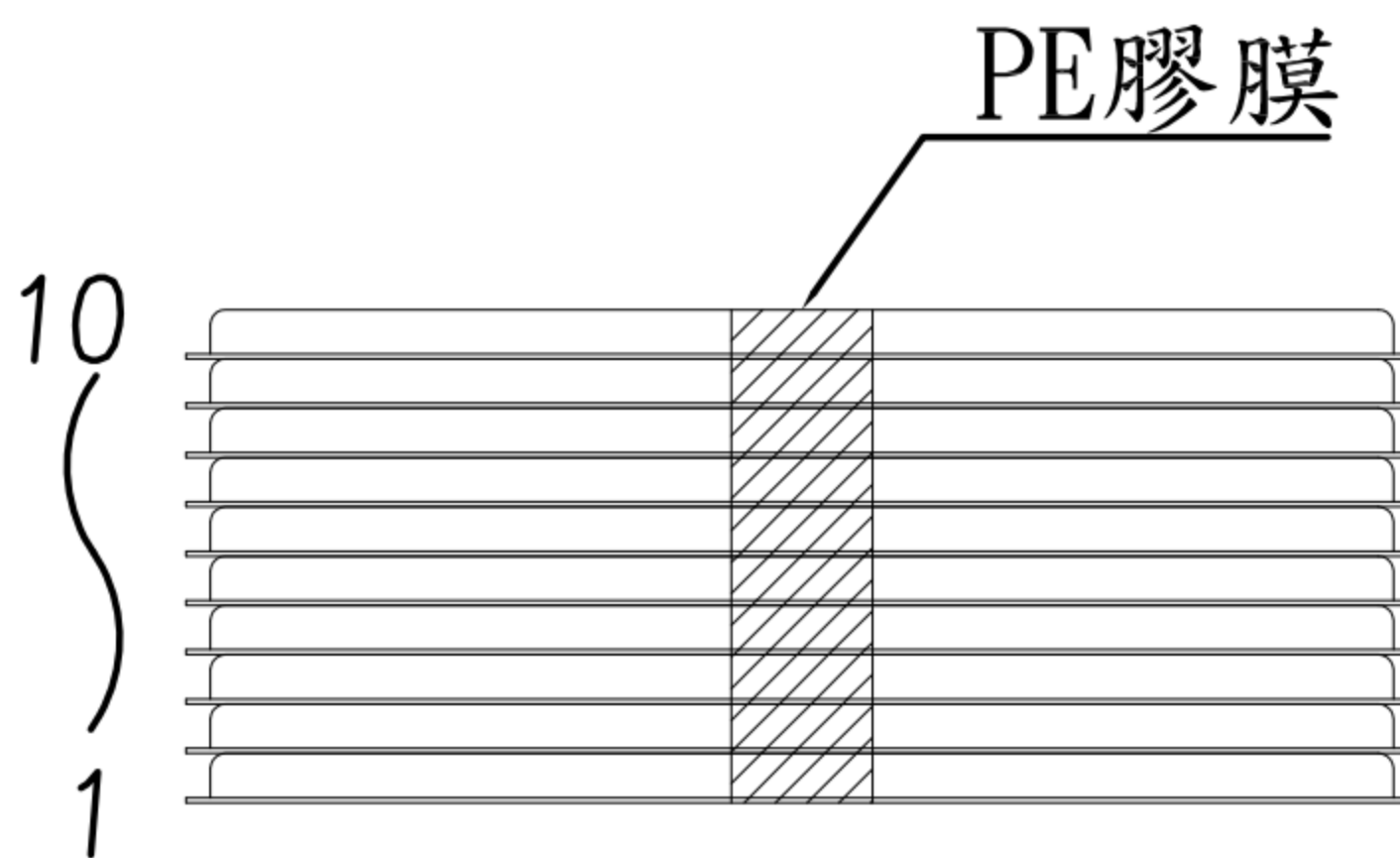
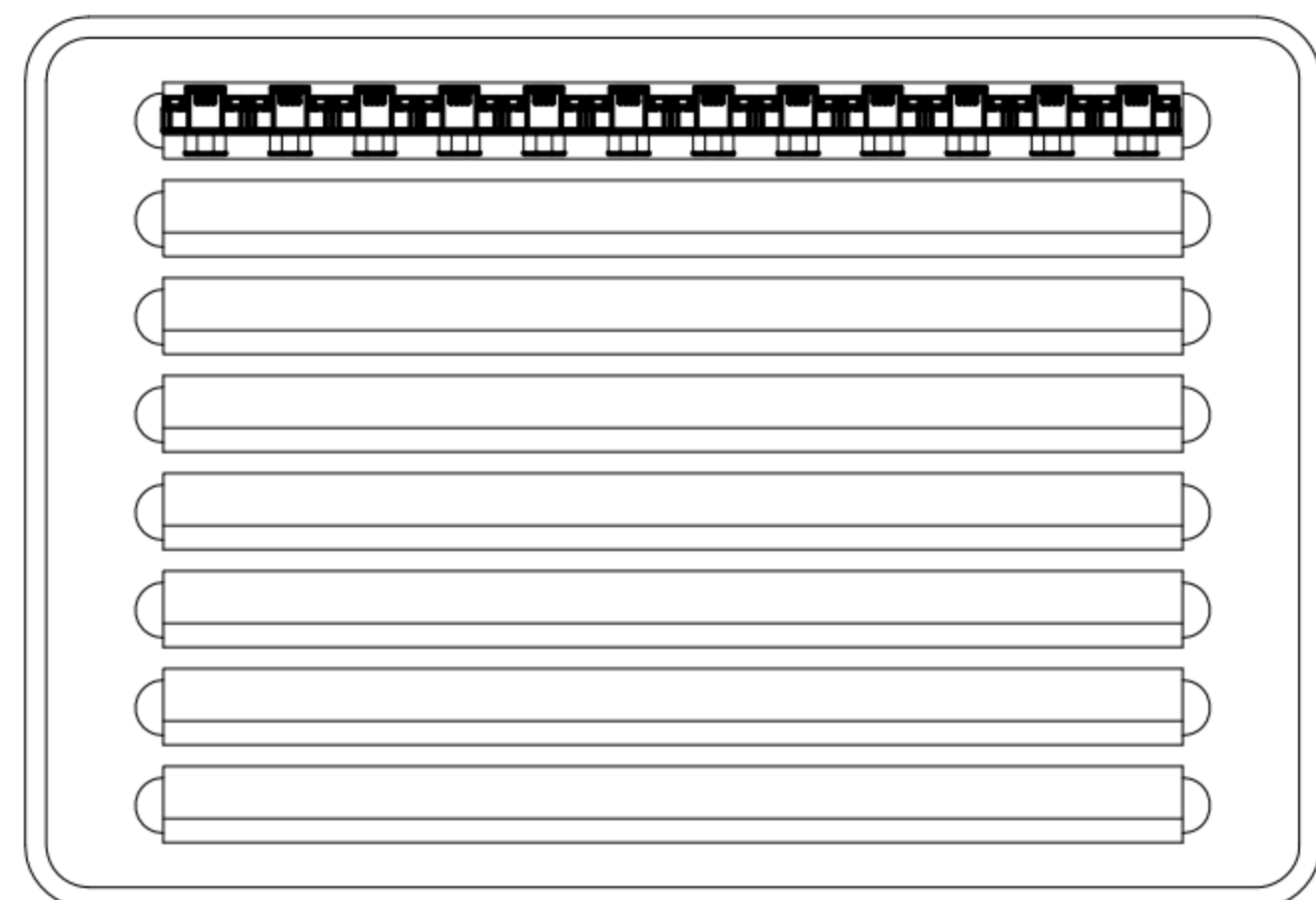
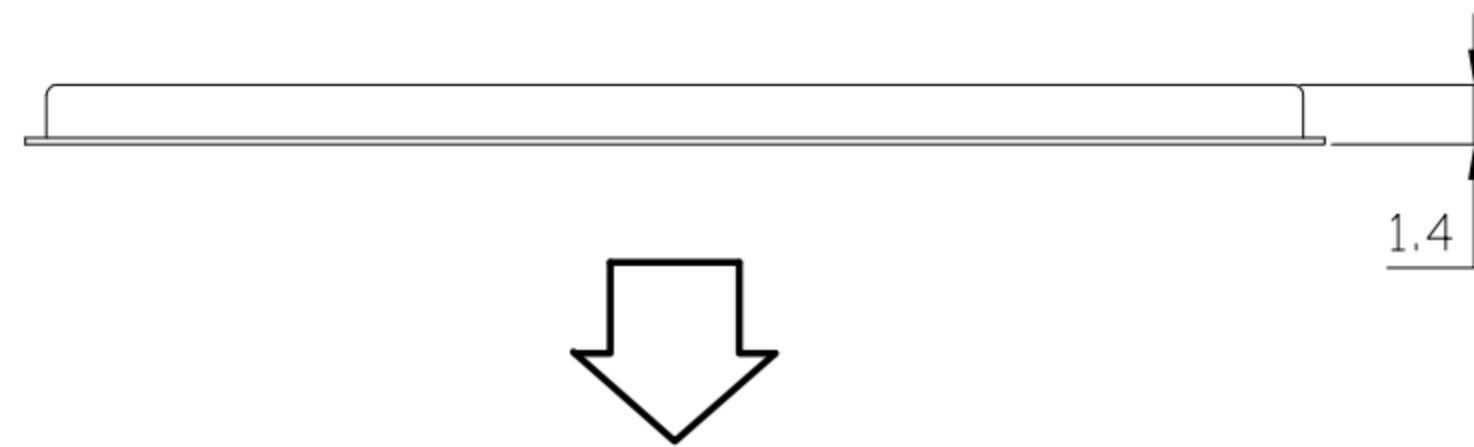
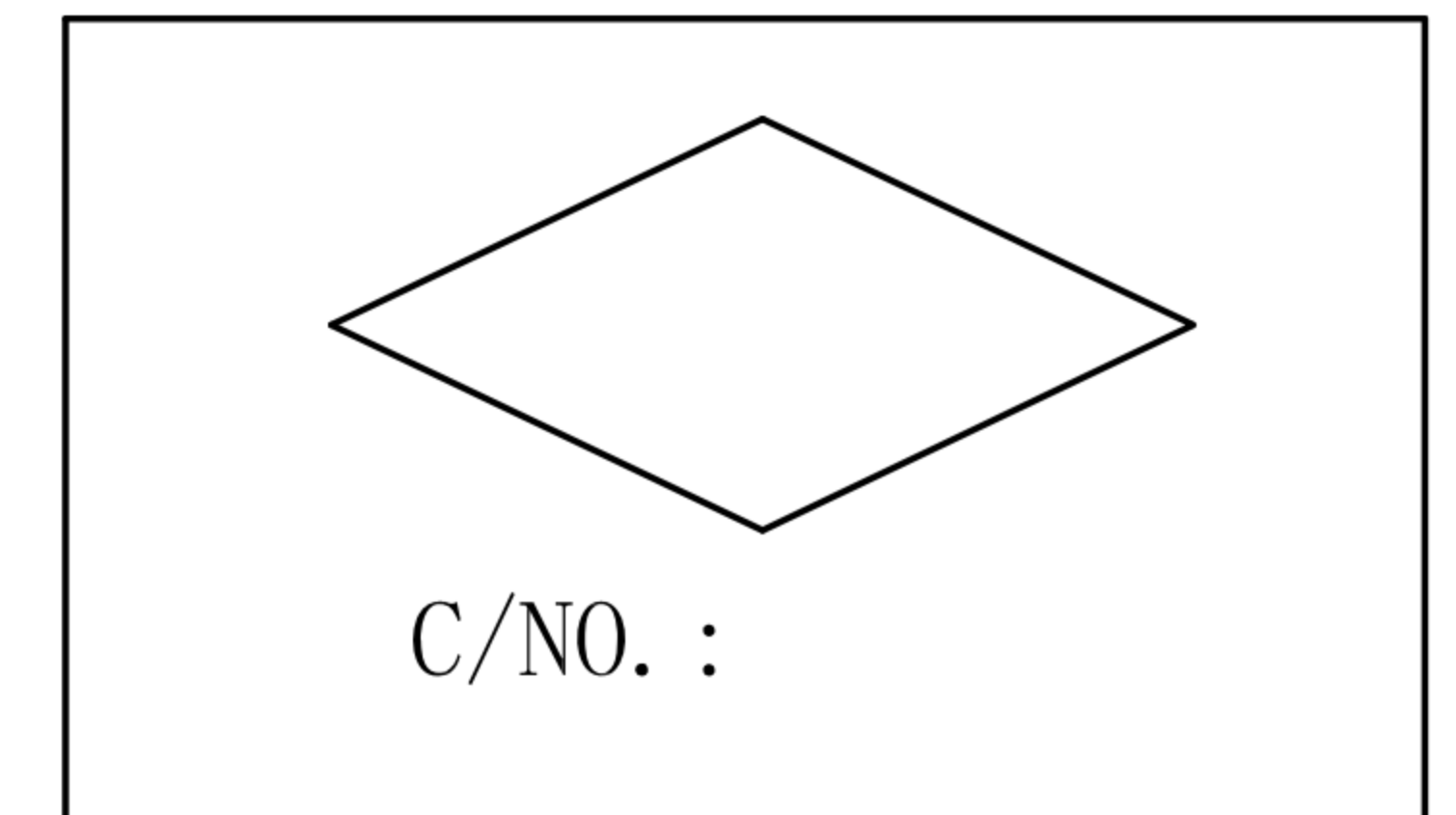

NOTE:

- 若有未裝滿之零數箱,必須以緩衝材塞滿.
- 在搬運過程中要輕拿輕放.
- 載運輸中不可堆放過多,不可有重壓現象.
- PE膠膜纏繞時不可緊綁.
- 紙箱內層需裝防水袋.

P/N	NUMBER OF PINS
DB-09F3-01	9
DB-15F3-01	15
DB-25F3-01	25

DRAW	Yeh Chou	APPVL	Emily Suen	UNIT	mm	TOLERANCE			TITLE	MICRO D-SUB MALE 9P-25P			SHEET
CHECK	Emily Suen			SCALE	1:1	.x ±0.20 .xx ±0.10 .xxx ±0.05 .xxxx ±0.03 ANGULA ±1°			PART NO.	SEE TABLE A	DWG NO.	QC1001	VERSION

广东科斯达电子科技有限公司
GUANG DONG KE SI DA ELECTRONIC TECHNOLOGY CO., LTD.

CUSTOMER DRAWING

REV.	DESCRIPTION	APPROVED BY	DATE	ECN NO.
A	RELEASE	Emily Suen	07/12/2011'	
B				
C				

P/N	NUMBER OF PINS	A	B	C	D	E	F	G
DB-09F3-01	9	19.93	14.35	5.08	14.35	10.41	14.35	8.30
DB-15F3-01	15	23.75	18.16	8.89	18.16	14.22	18.16	12.20
DB-25F3-01	25	30.10	24.51	15.23	24.51	20.57	24.51	18.55

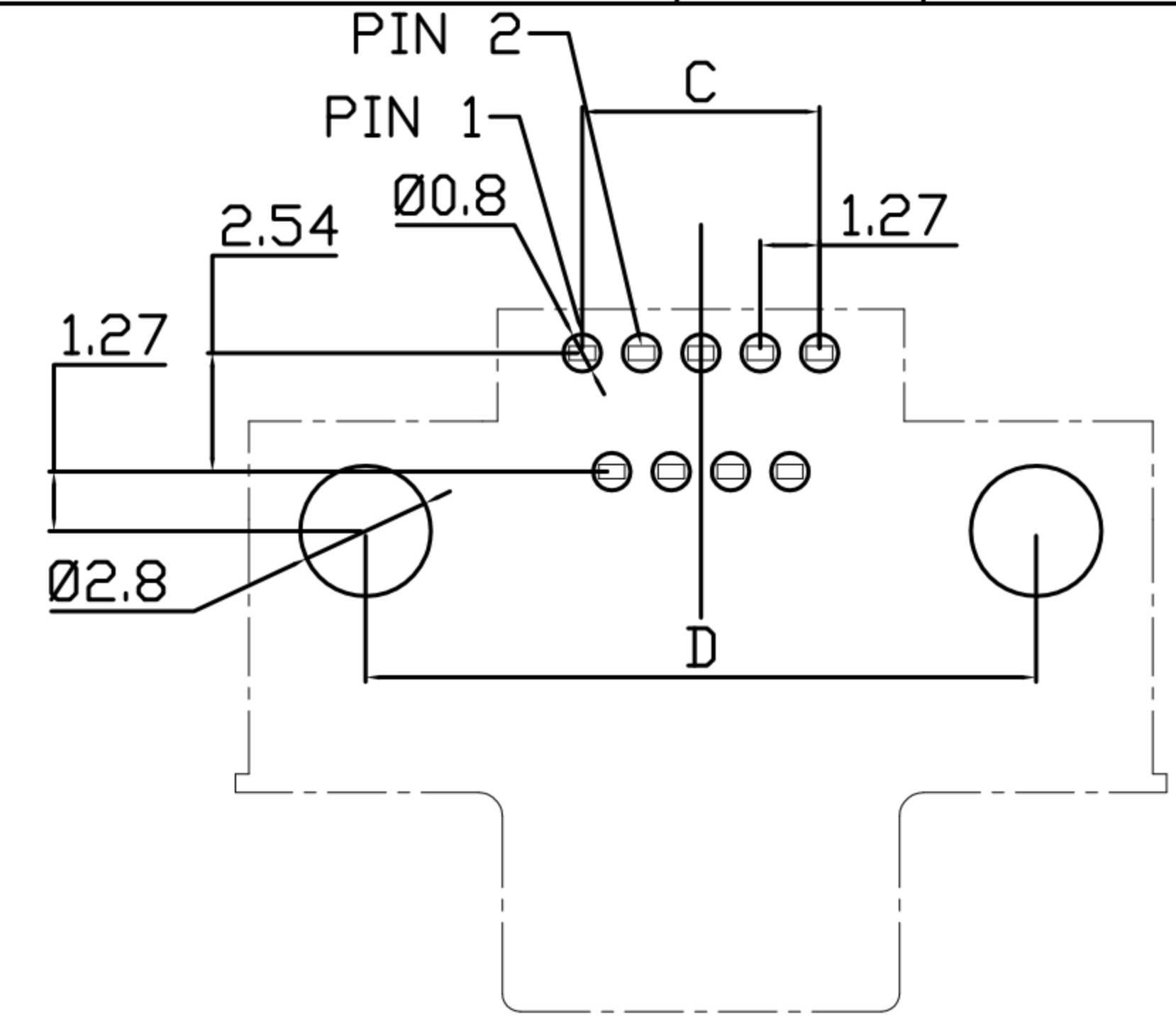
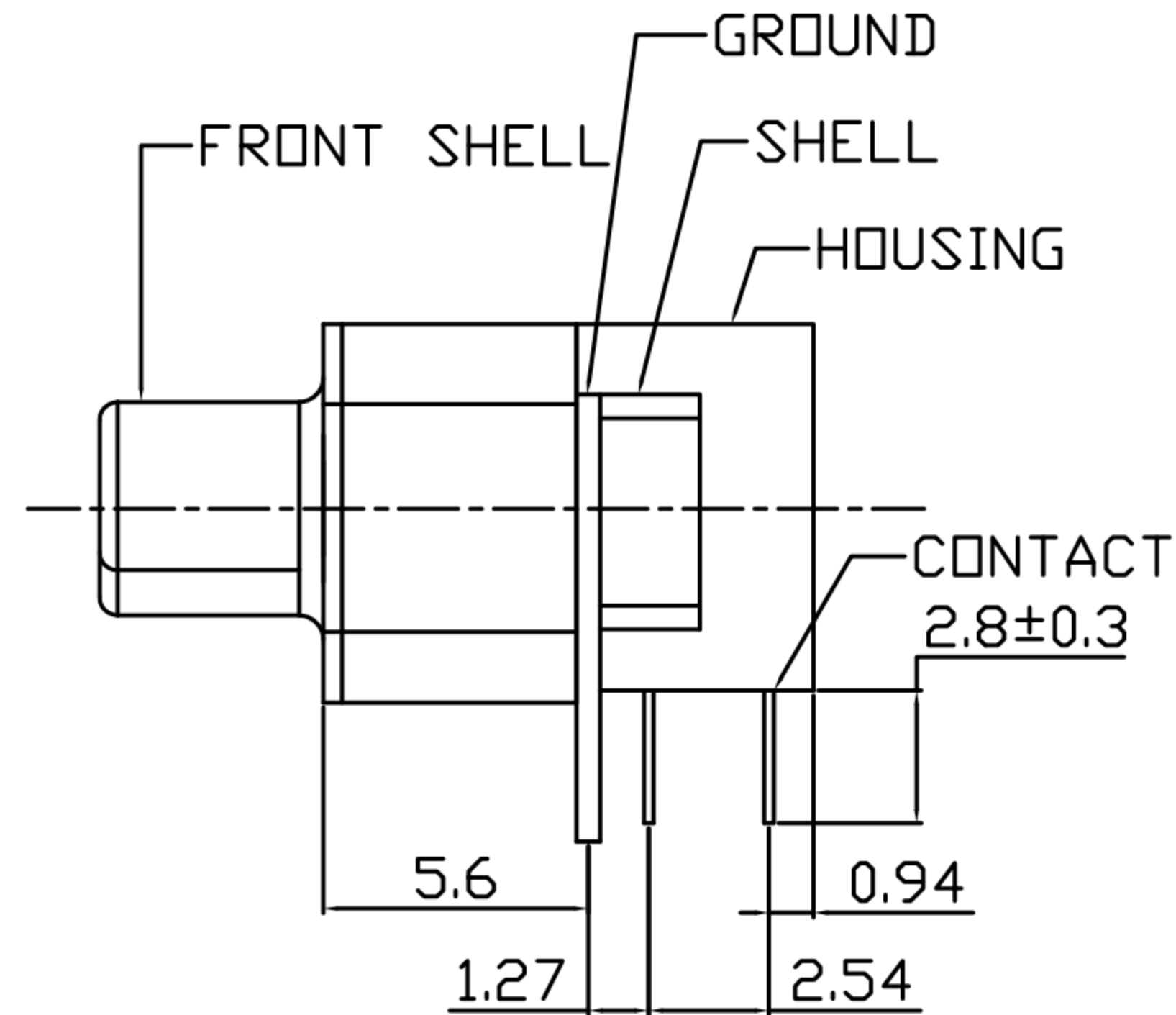
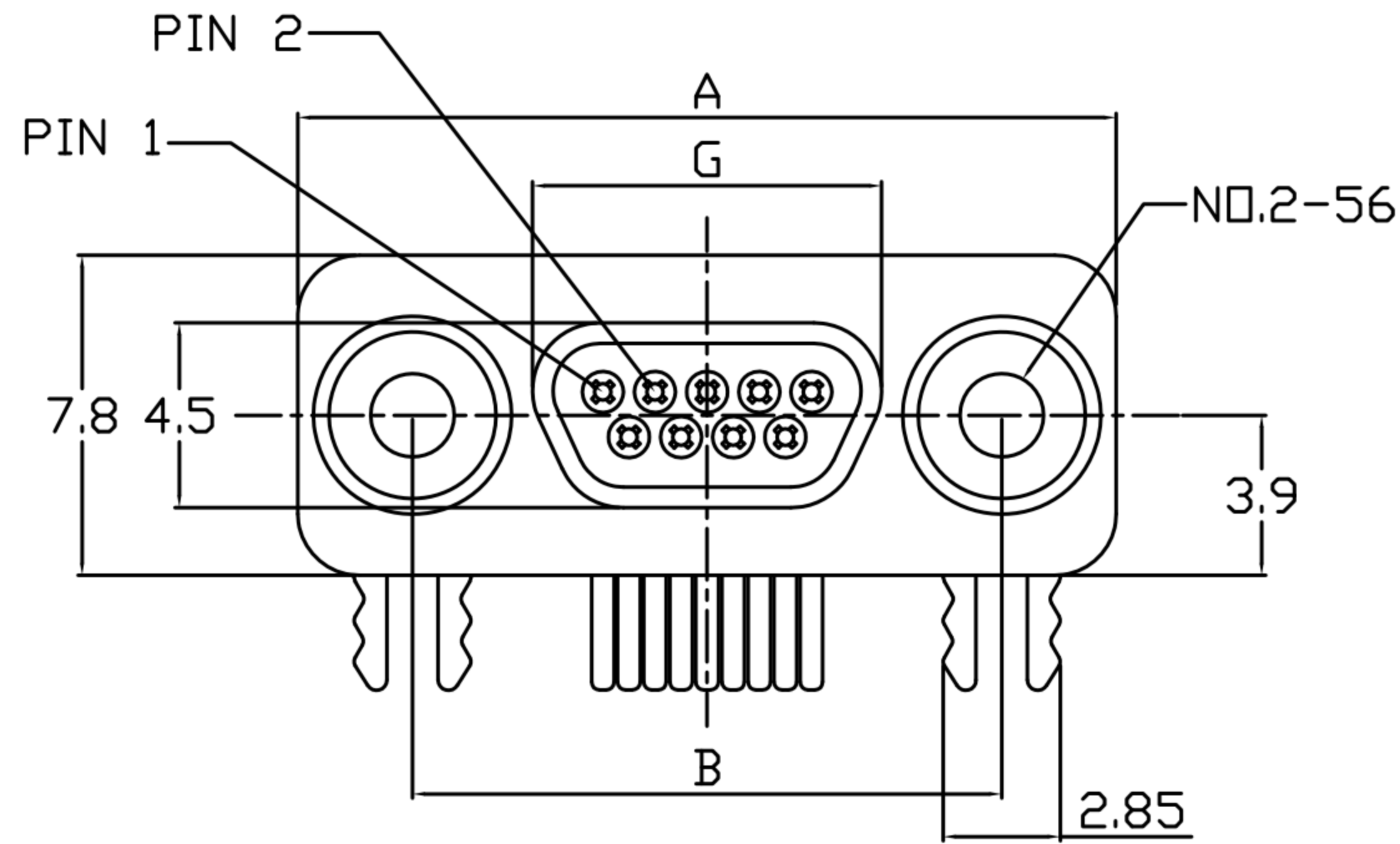

P.C.B LAYOUT

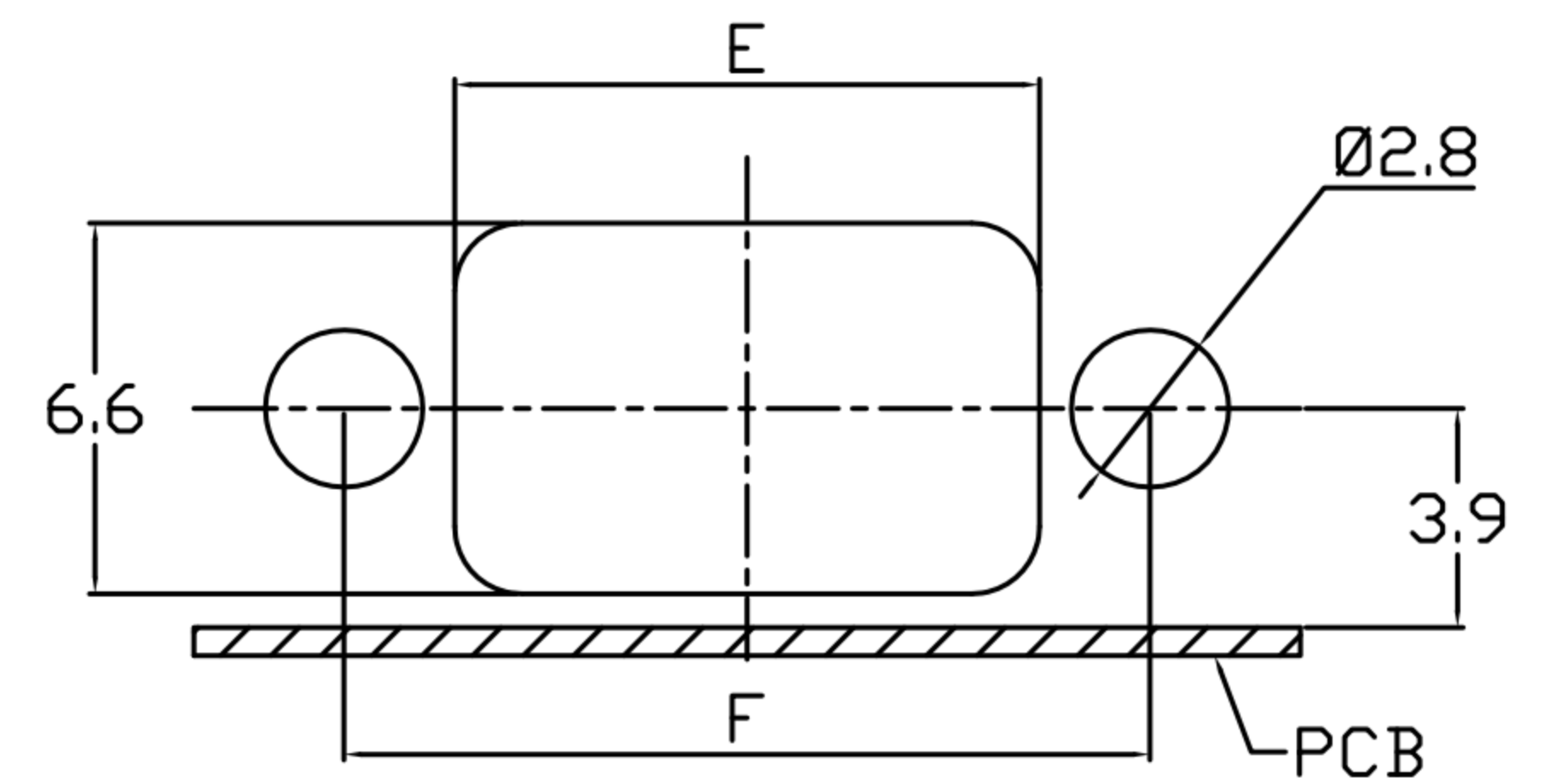
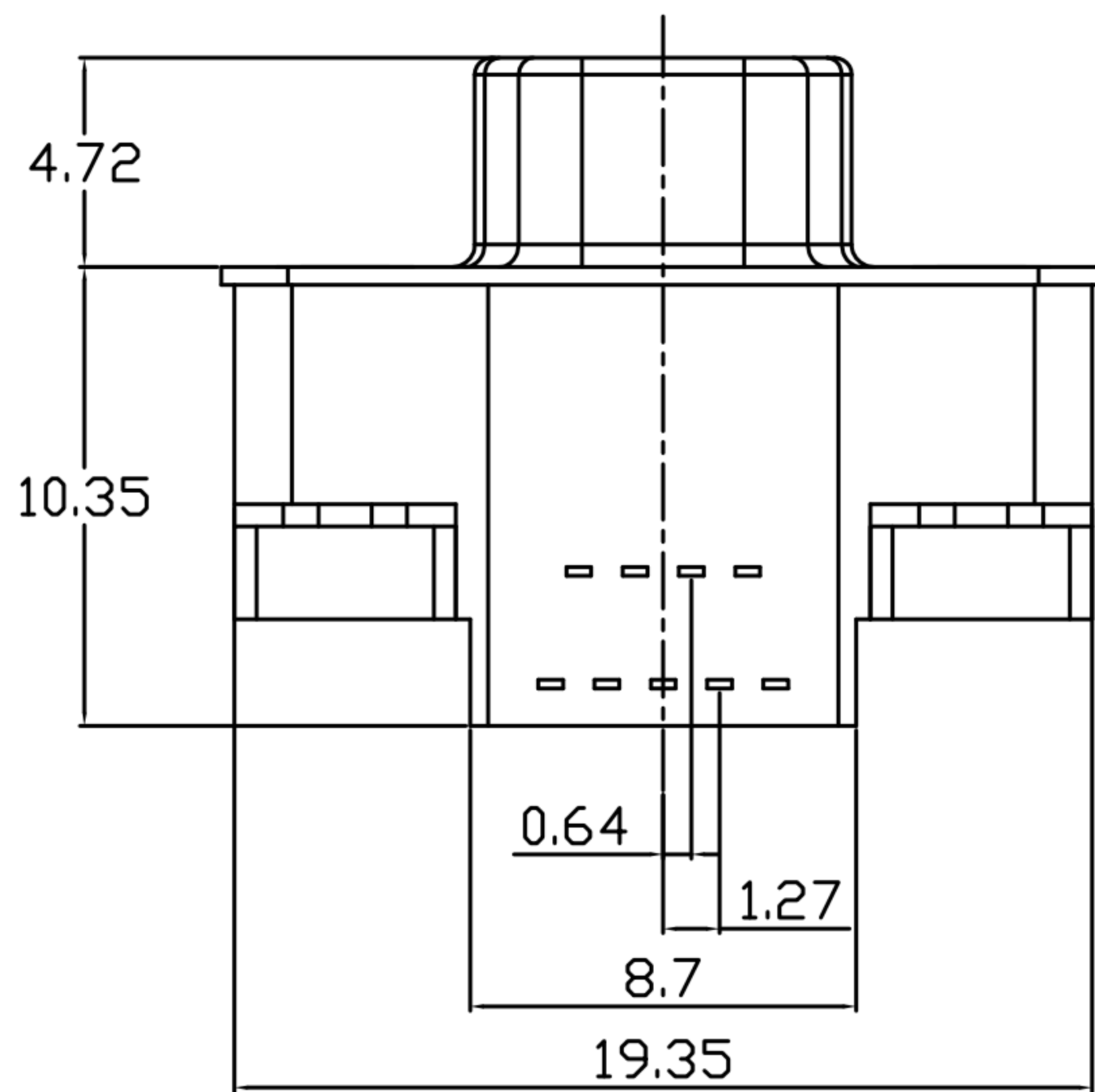

PANEL CUT-OUT

1. MATERIAL :
 - 1-1. HOUSING : LCP UL94V-0 ; COLOR : BLACK
 - 1-2. CONTACT : PHOSPHOR BRONZE
 - 1-3. FRONT SHELL : SPCC
 - 1-4. SHELL : BRASS
 - 1-5. GROUND : BRASS
2. FINISH :
 - 2-1. CONTACT : GOLD 15u" ON CONTACT AREA
MATTE TIN 60u" ON SOLDER AREA
 - 2-2. FRONT SHELL : NICKEL PLATED 60u" ~ 100u" OVER ALL
 - 2-3. SHELL : NICKEL PLATED 60u" ~ 100u" OVER ALL
 - 2-4. GROUND : NICKEL PLATED 60u" ~ 100u" OVER ALL
3. ELECTRICAL SPECIFICATION :
 - 3-1. Rated current : 1A
 - 3-2. Voltage : 30V
4. Environmental :
 - 4-1. Operation Temperature : -40℃~+125℃

DRAWN	Yeh Chou	APP'D	Ku Chou	UNIT	mm	TOLERANCE		TITLE	MICRO D-SUB 9-25P(F) 板上90°			SHEET
CHK'D	Emily Suen			SCALE	1:1	.x ±0.20 .xx ±0.15 .xxx ±0.10 .xxxx ±0.05 ANGULA ±1°		PART NO.	SEE TABLE A	DWG NO.	QC4934	VERSION

广东科斯达电子科技有限公司
 GUANG DONG KE SI DA ELECTRONIC TECHNOLOGY CO., LTD.