

CUSTOMER DRAWING

| REV. | DESCRIPTION | APPROVED BY | DATE | ECN NO. |
|------|---------------------|-------------|-----------|-----------|
| △A | RELEASE | Fido Weng | 22/12/08' | |
| △B | CHANGE CONTACT TYPE | Emily Suen | 17/09/12' | ECN12025. |
| △C | 修改外觀 | Emily Suen | 04/10/12' | ECN12027 |
| △D | 修改外觀總長 | Fido Weng | 21/06/13' | |

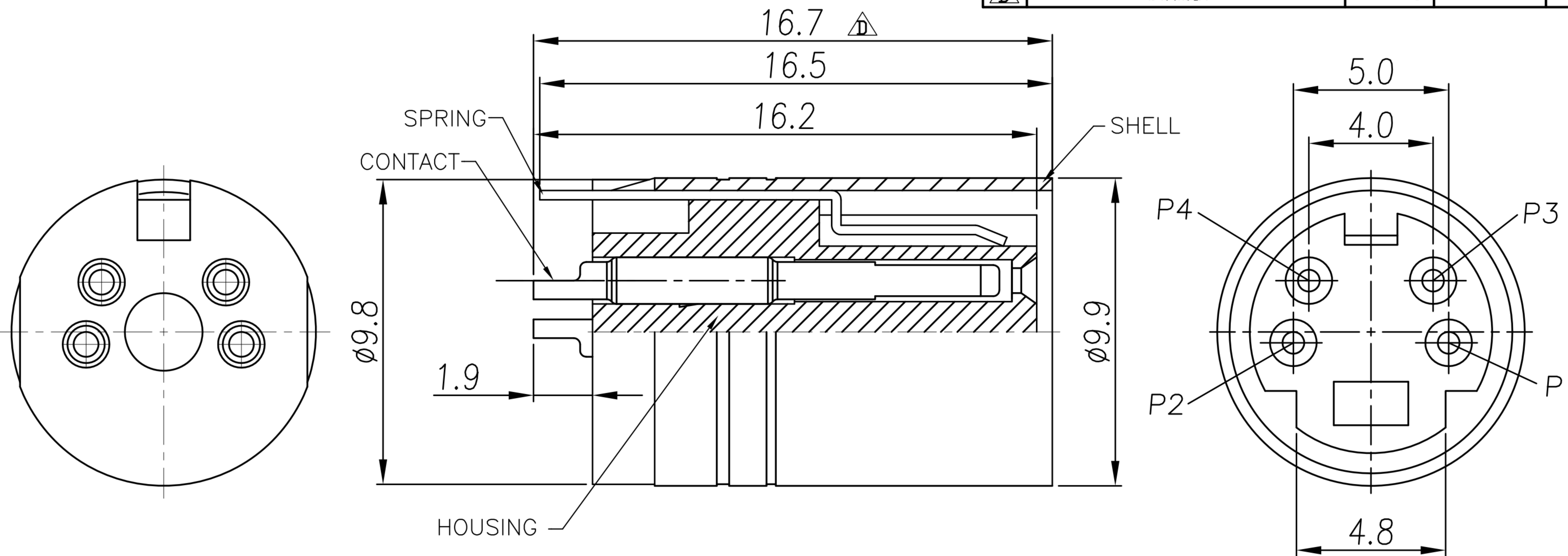

- MATERIAL :
 - 1-1. HOUSING : PBT UL94V-0 ; COLOR : BLACK
 - 1-2. CONTACT : PHOSPHOR BRONZE
 - 1-3. SHELL : BRASS
 - 1-4. SPRING : PHOSPHOR BRONZE
- FINISH :
 - 2-1. CONTACT : SEE TABLE A
UNDER PLATE : NICKEL
 - 2-2. SHELL : SEE TABLE A
 - 2-3. SPRING : SILVER PLATED

TABLE A

| | | | | |
|--|------------|----------------|-------------|------------|
| | MD-04F1-13 | GOLD FLASH | NO | NICKEL |
| | MD-04F1-12 | GOLD FLASH | NO | GOLD FLASH |
| | MD-04F1-08 | SILVER | NO | NICKEL |
| | MD-04F1-07 | GOLD FLASH | YES | NICKEL |
| | MD-04F1-04 | SILVER | YES | NICKEL |
| | PART NO. | CONTACT PLATED | WITH SPRING | SHELL |

| | | | | | | | | | | | | | |
|-------|------------|-------|------------|-------|-----|--|--|--|----------|-------------------|---------|--------|---------|
| DRAWN | Ku Chou | APP'D | Emily Suen | UNIT | mm | TOLERANCE | | 广东科斯达电子科技有限公司 GUANG DONG KE SI DA ELECTRONIC TECHNOLOGY CO., LTD. | TITLE | MINI DIN 4PIN (F) | | | SHEET |
| CHK'D | Emily Suen | | | SCALE | 1:1 | .x ±0.20 .xx ±0.10 .xxx ±0.05 .xxxx ±0.03 ANGULA ±1° | | | PART NO. | SEE TABLE A | DWG NO. | QC0008 | VERSION |