

CUSTOMER DRAWING

REV.	DESCRIPTION	APPROVED BY	DATE	ECN NO.
△A				
△B	修正總長	Fido Weng	06/08/13'	
△C				

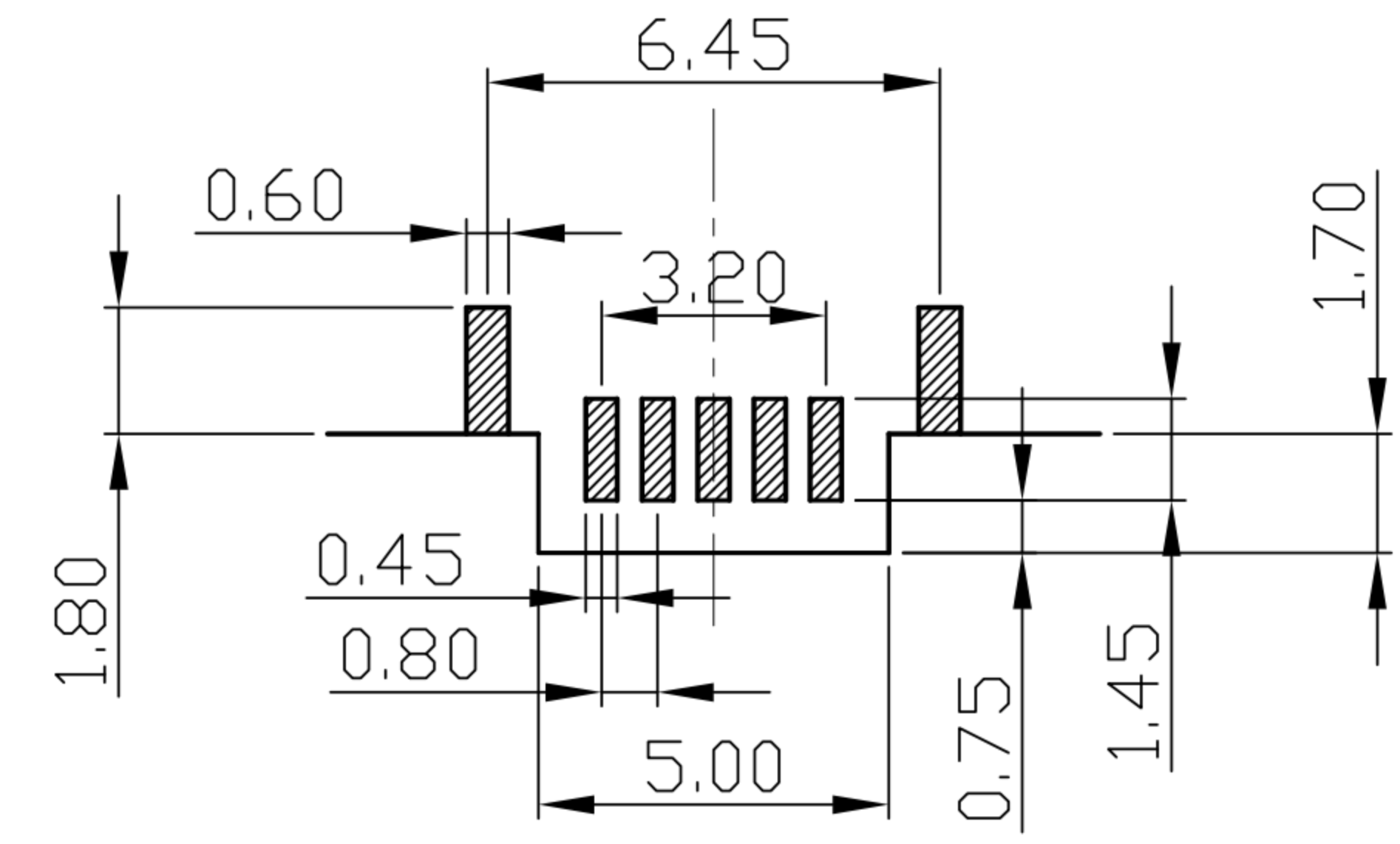

Recommend P.C.B Layout

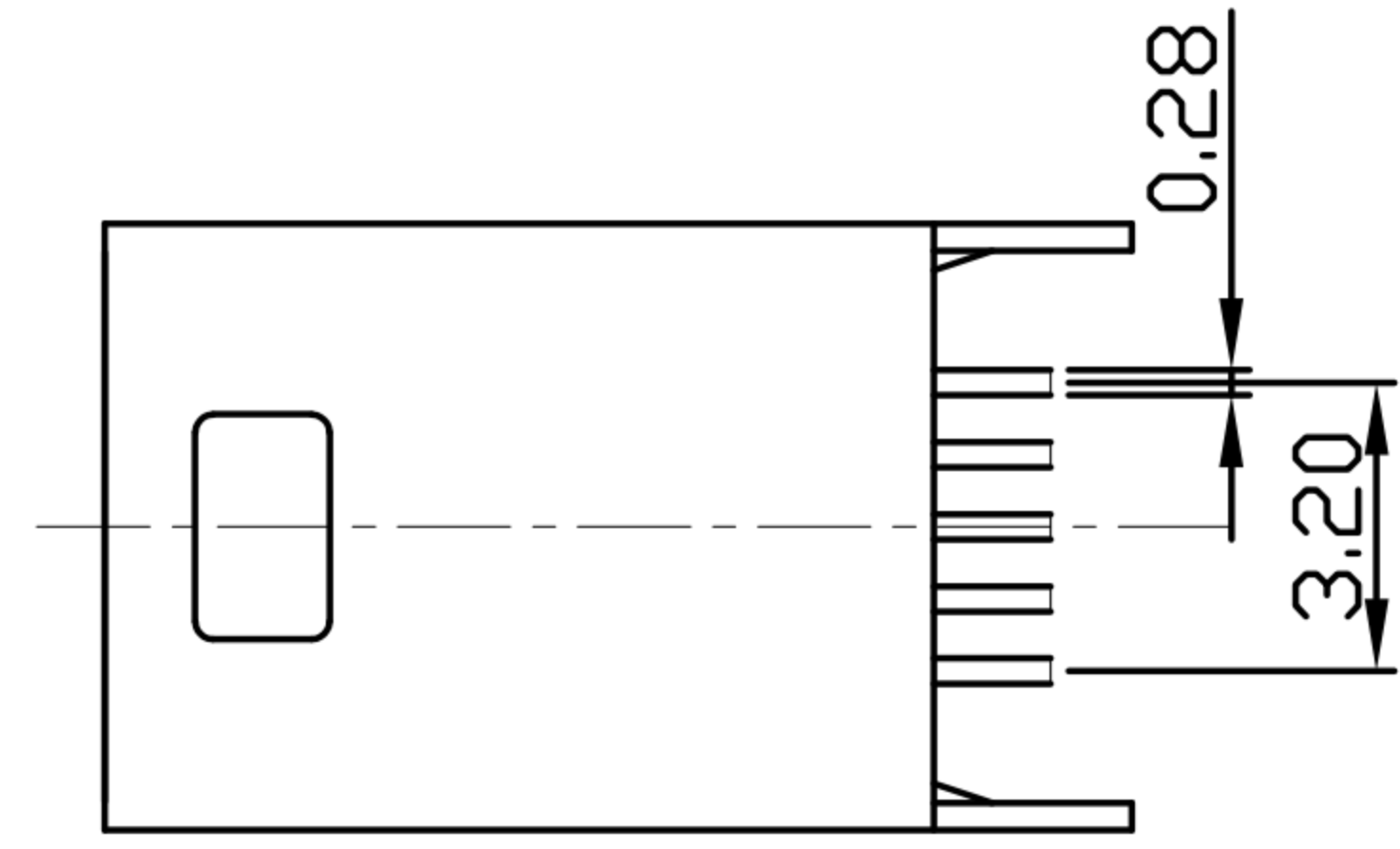
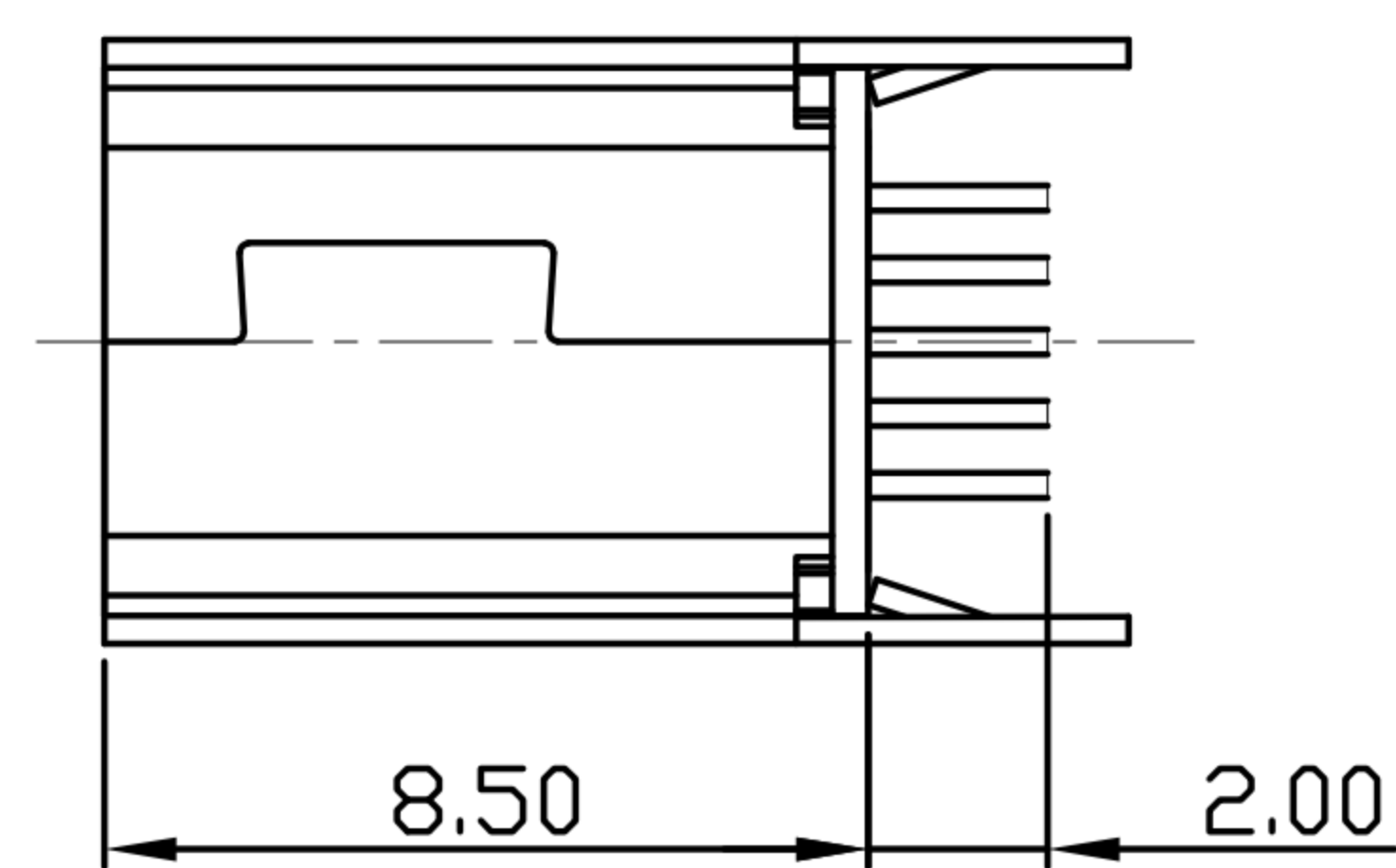
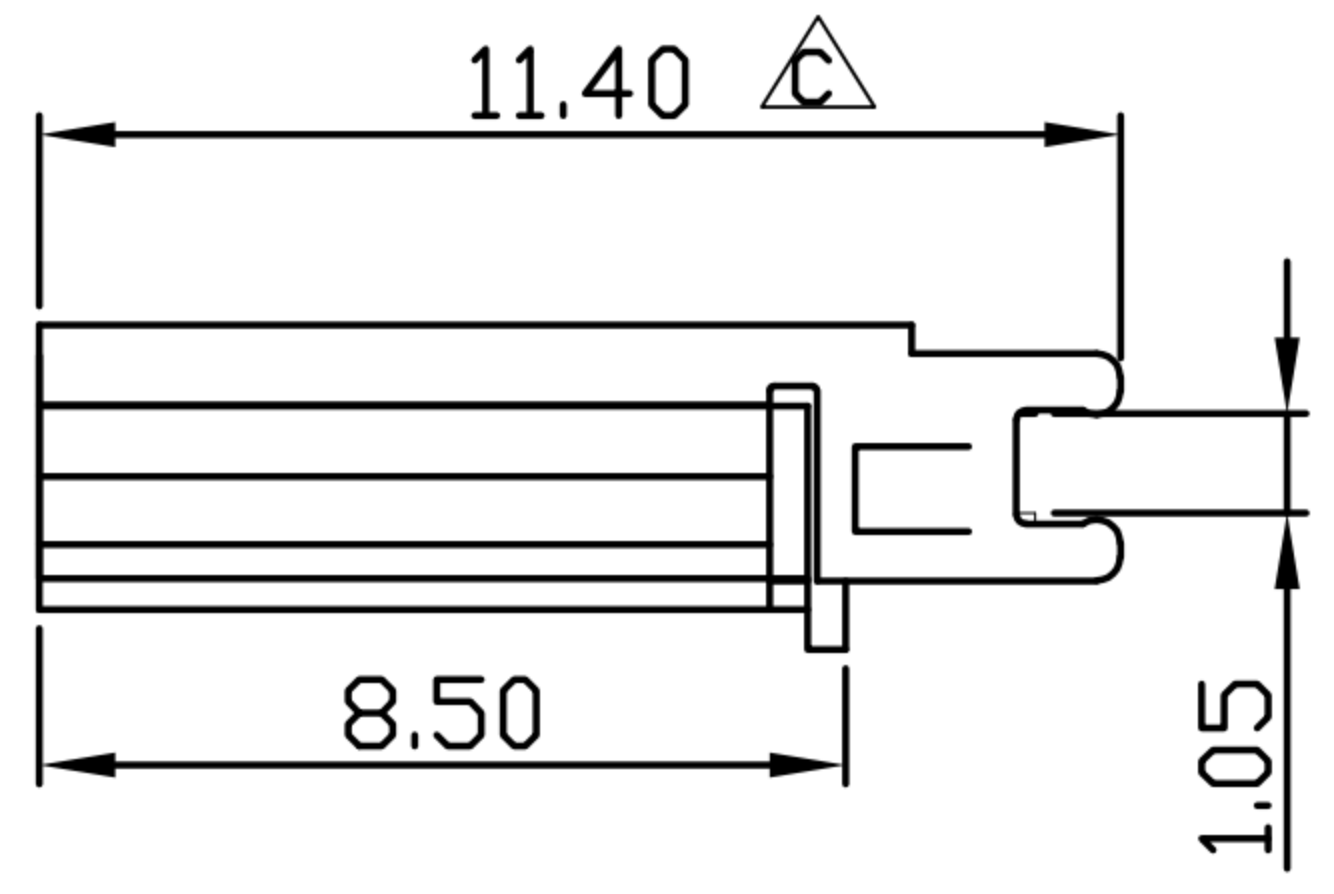
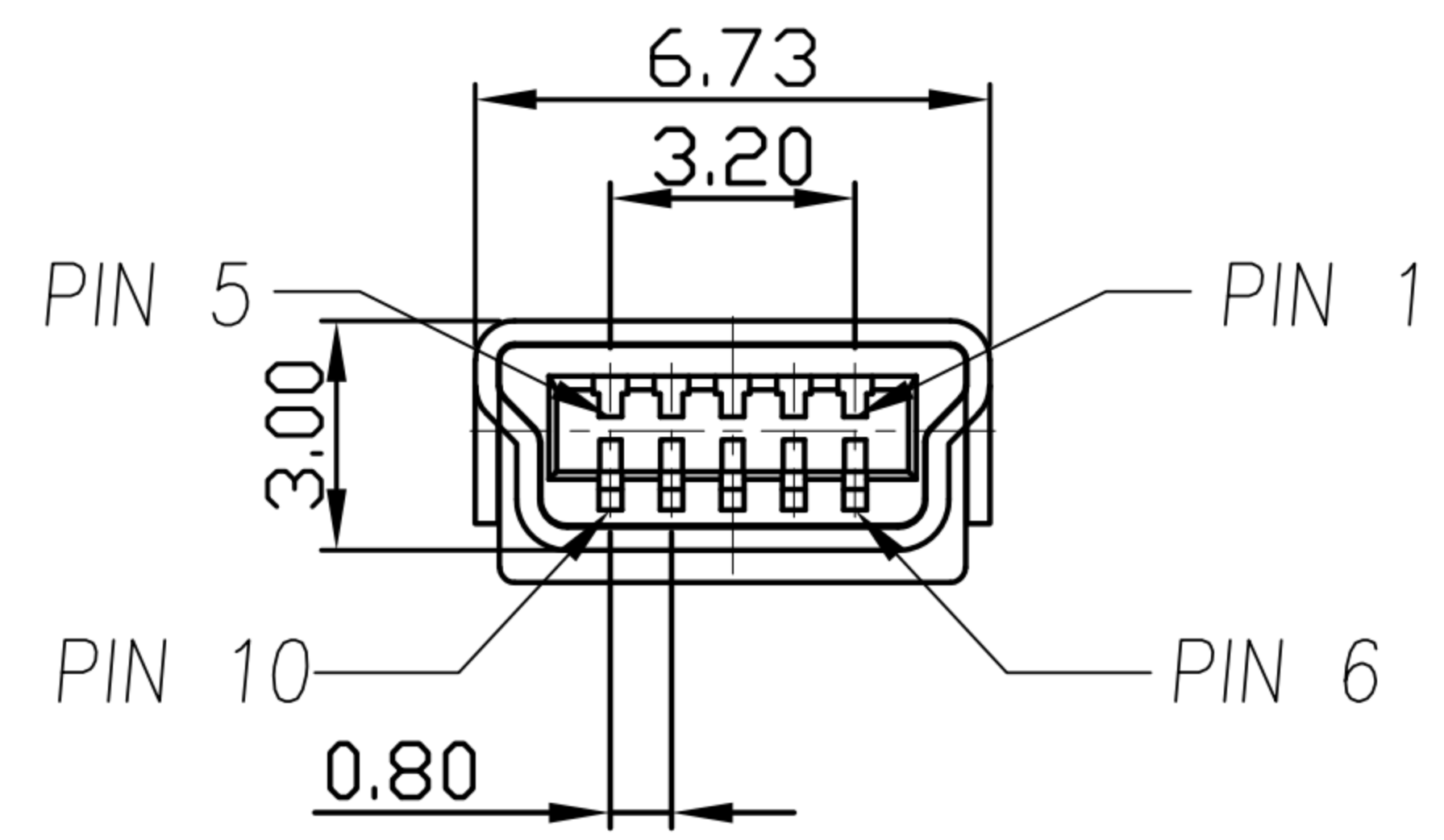

NOTE:

- 1.MATERIAL:
 - 1-1.TERMINAL : PHOSPHOR BRONZE(C5191R-H),T=0.20±0.015mm.
 - 1-2.HOUSING : LCP
 - 1-3.SHELL : BRASS C2680 T=0.30±0.01.
- 2.PLATING:
 - 2-1.CONTACT: GOLD 10u" MIN ON CONTACT AREA, GOLD FLISH MIN ON SOLDER TAILS, UNDERPLATED NICKEL OVER ALL 50u" MIN.
 - 2-2.SHELL: NICKEL 60u", SMT GOLD FLISH ON ALL AREA

DRAWN	Jen Xie	APP'D	Fido Weng	UNIT	mm	TOLERANCE			TITLE	MINI USB 10PIN(M)半成品			SHEET	
CHK'D	Enly Suen			SCALE	1:1	.x ±0.20 .xx ±0.10 .xxx ±0.05 .xxxx ±0.03 ANGULA ±1°			PART NO.	NY-US304	DWG NO.	QC5441	VERSION	