

CUSTOMER DRAWING

REV.	DESCRIPTION	APPROVED BY	DATE	ECN NO.
A	RELEASE	Emily Suen	22/11/11'	
B				
C				
D				

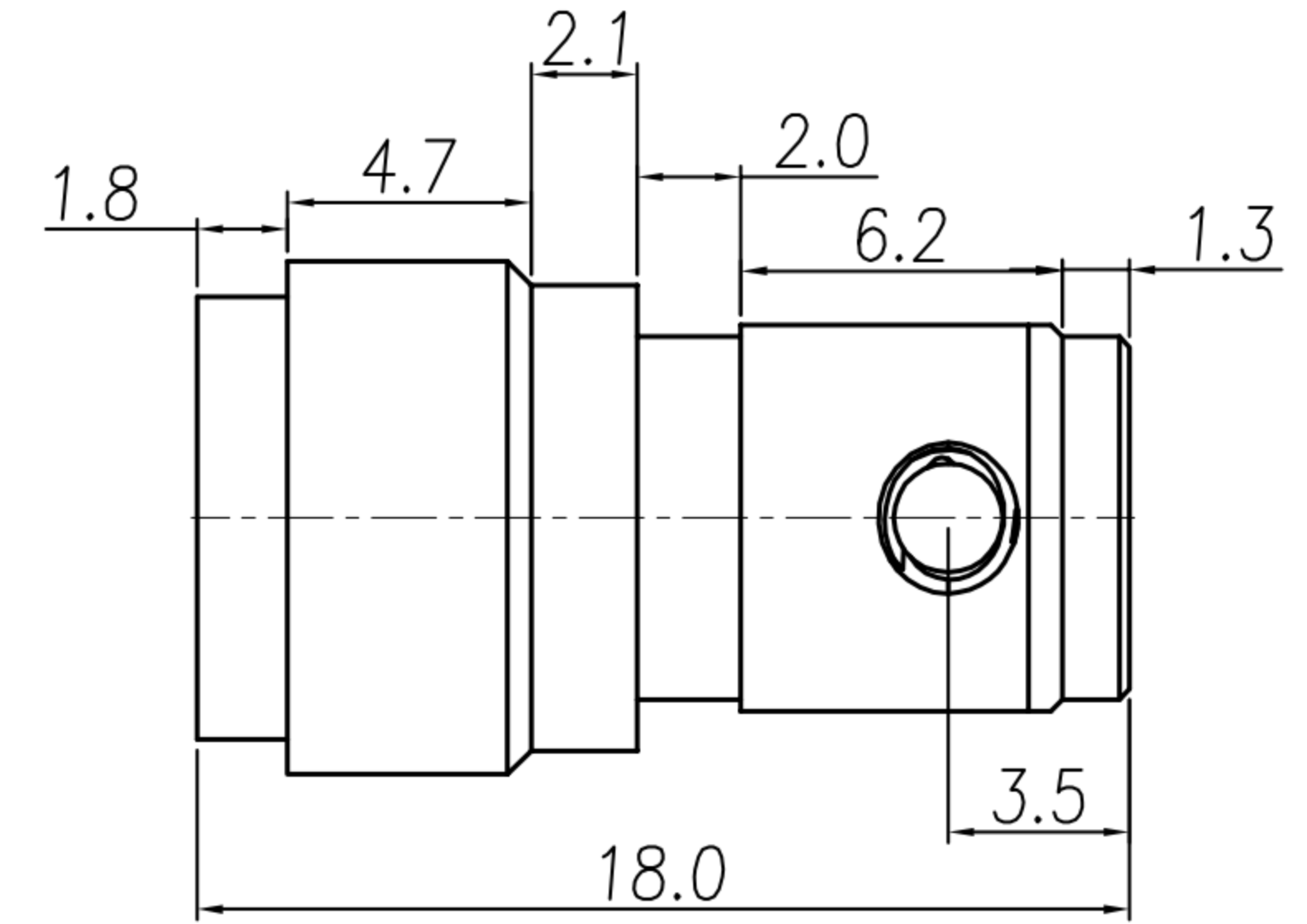
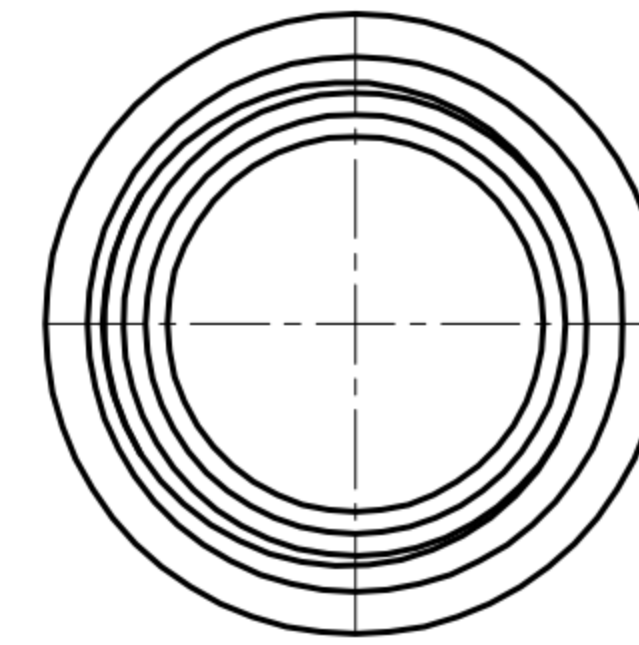
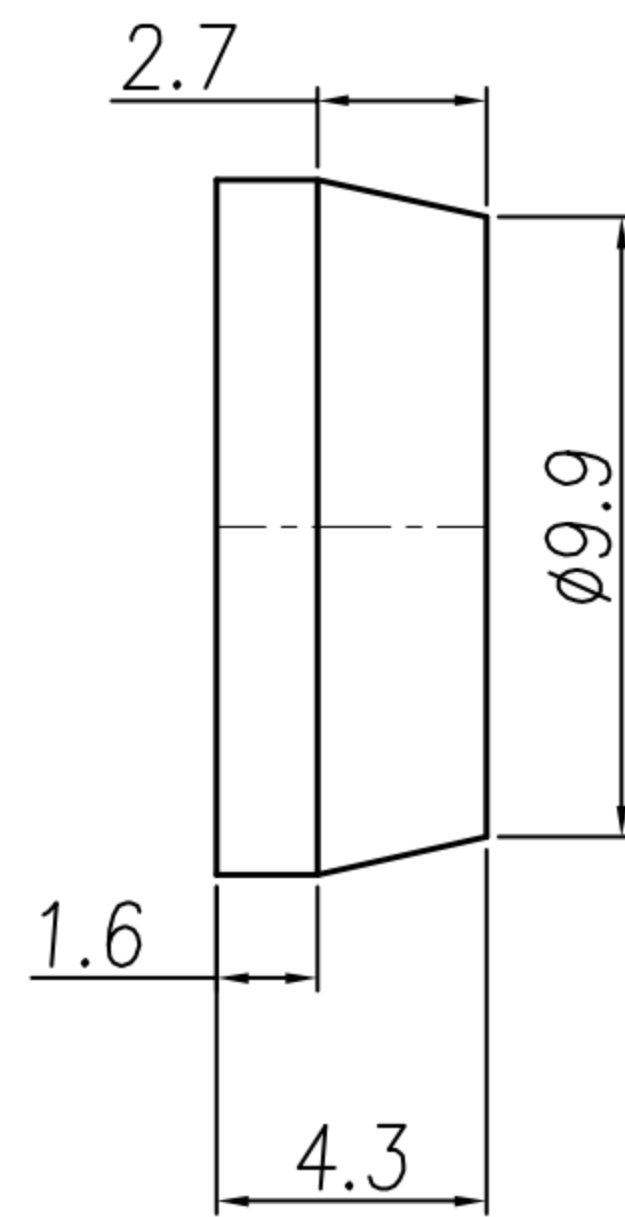
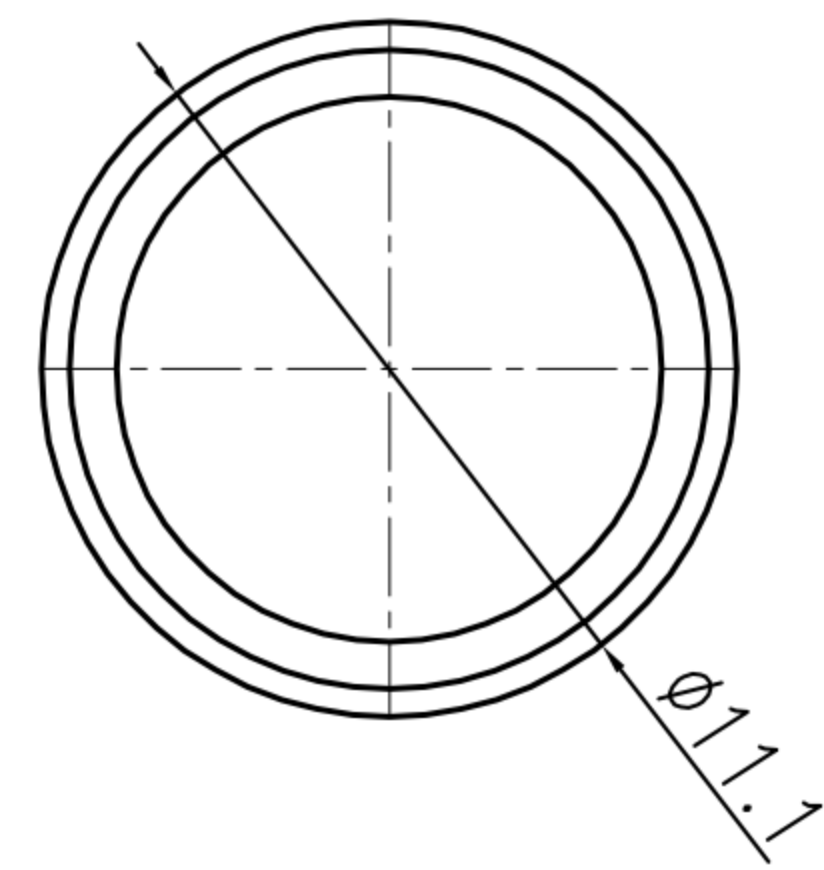
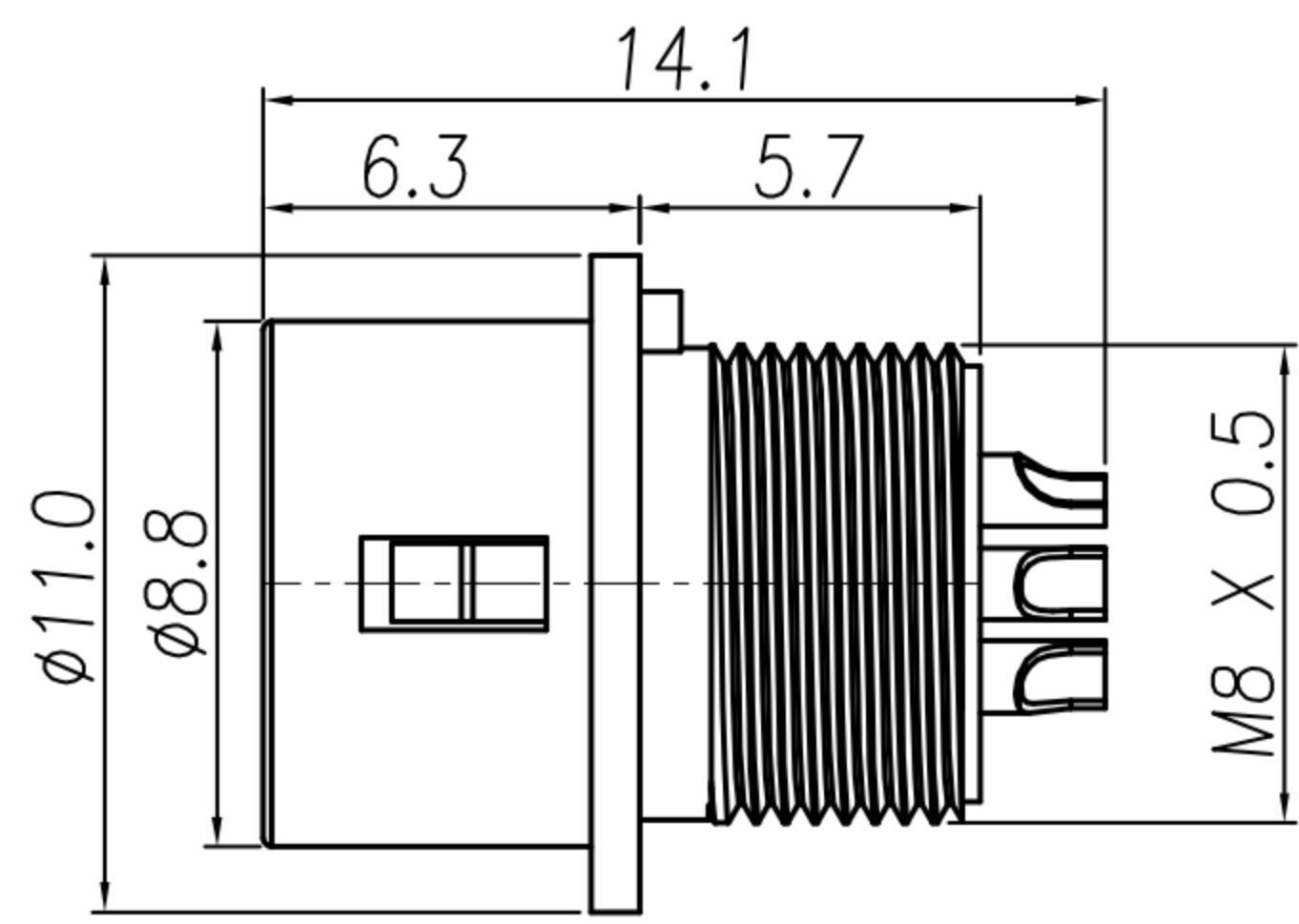

HOUSING + CONTACT + SHELL A

SHELL B

SHELL C

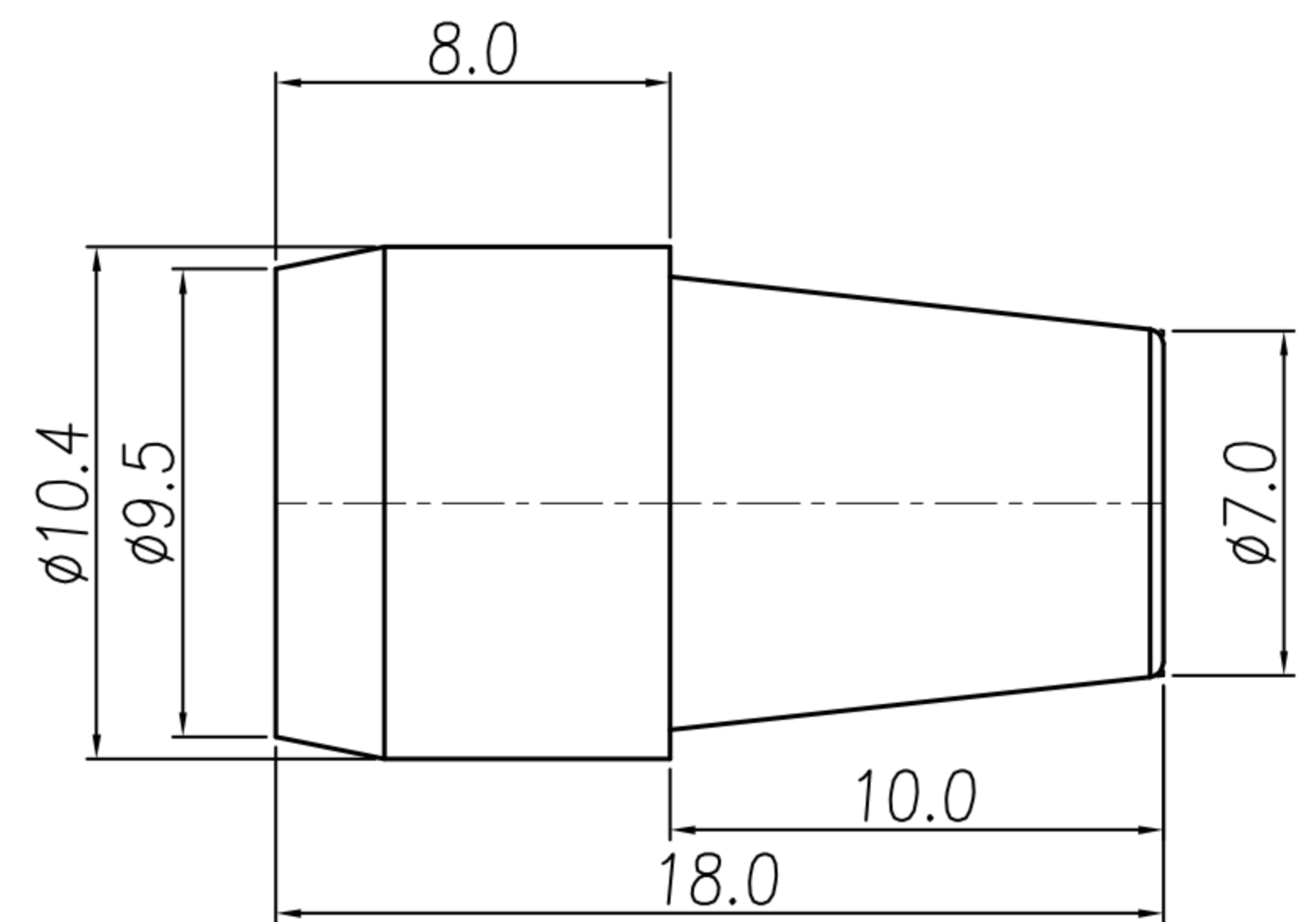
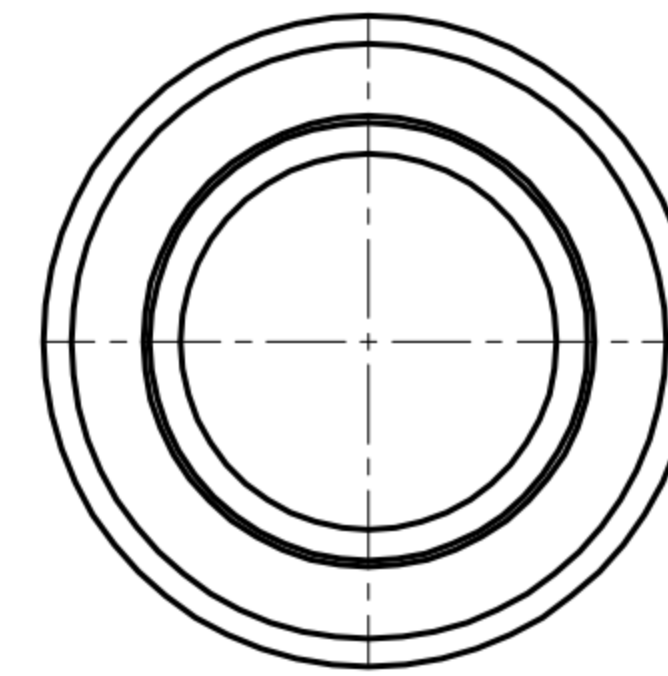
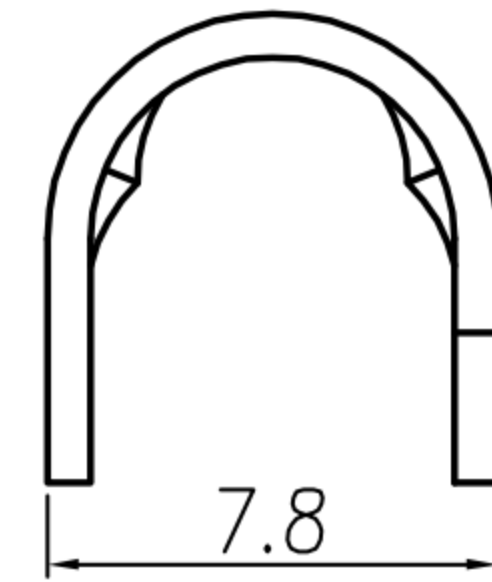
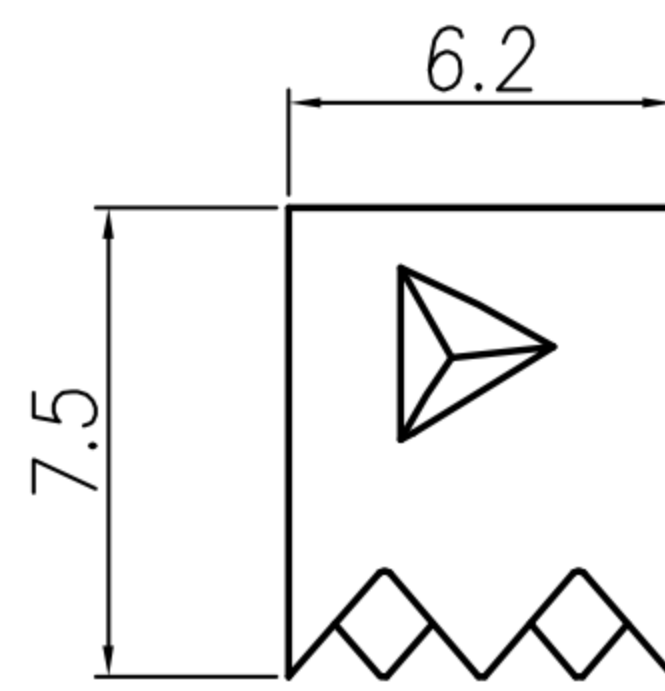
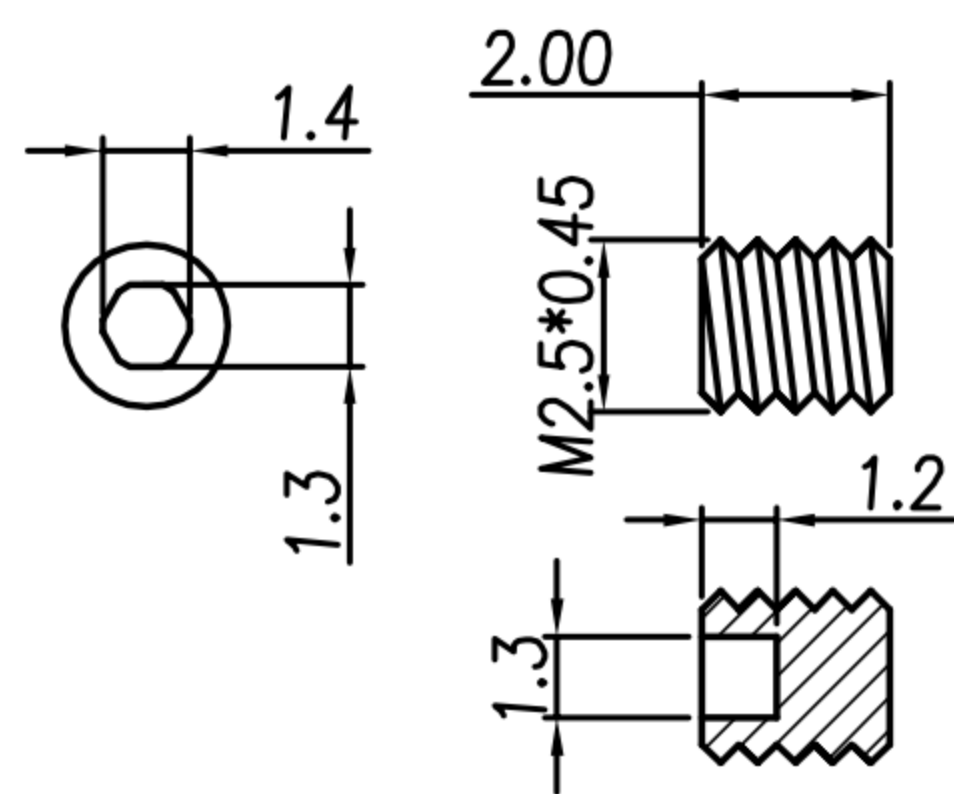

SCREW

CRAMP

SR

DRAWN	Mark Kao	APPV'L	Ku Chou	UNIT	mm	TOLERANCE		广东科斯达电子科技有限公司 GUANG DONG KE SI DA ELECTRONIC TECHNOLOGY CO., LTD.	TITLE	DIN (F) JACK 插孔式 (SHELL SIZE 7mm)			SHEET	2/2
CHK'D	Emily Suen			SCALE	1:1	.x ±0.20 .xx ±0.10 .xxx ±0.05 .xxxx ±0.03 ANGULA ±1°			PART NO.	SEE TABLE A	DWG NO.	QC5667	VERSION	A

CUSTOMER DRAWING

REV.	DESCRIPTION	APPROVED BY	DATE	ECN NO.
△A	RELEASE	Emily Suen	22/11/11'	
△B	CHANGE MATERIAL	Emily Suen	19/09/22'	
△C				
△D				

TABLE A

CONTACT ARRANGEMENT(FRONT VIEW)			
DI-04F2-06	DI-05F2-03	DI-06F2-07	DI-07F2-03

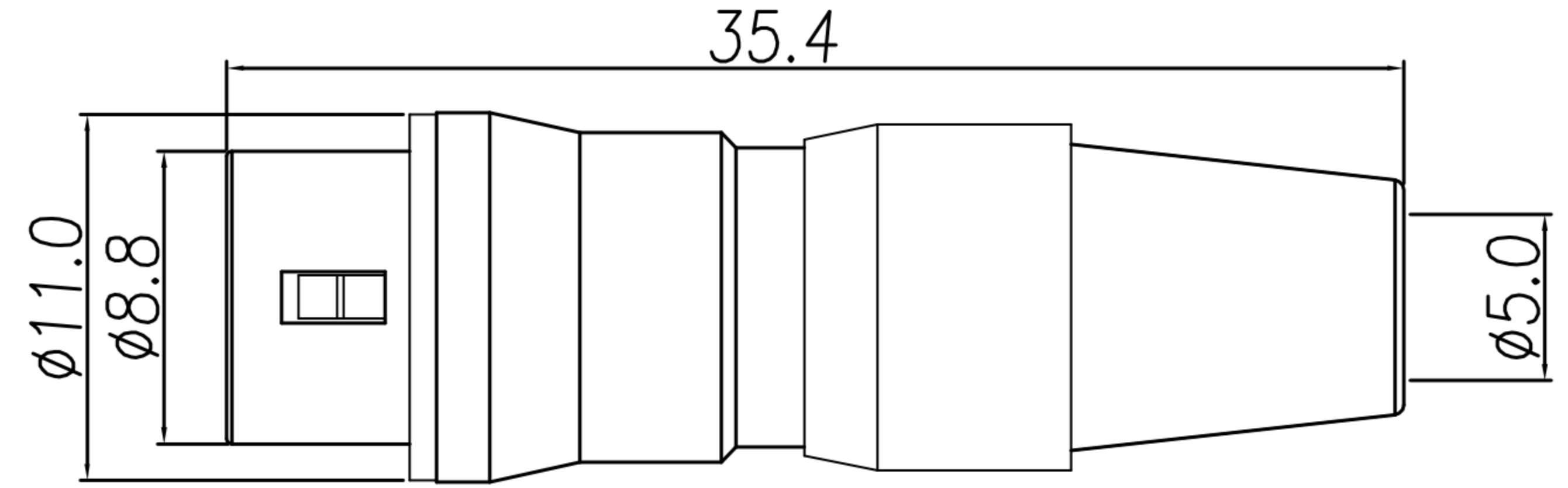

- MATERIAL :
  - △B 1-1. HOUSING : NYLON66 UL94V-0 ; COLOR : BLACK
  - 1-2. CONTACT : PHOSPHOR BRONZE
  - 1-3. SHELL A : ZINC ALLOY
  - 1-4. SHELL B : BRASS
  - 1-5. SHELL C : BRASS
  - 1-6. SCREW : ALLOY STEEL
  - 1-7. CRAMP : BRASS
  - 1-8. SR : NBR ; COLOR : BLACK
- FINISH :
  - 2-1. CONTACT : GOLD FLASH
  - 2-2. SHELL A : NICKEL
  - 2-3. SHELL B : NICKEL
  - 2-4. SHELL C : NICKEL
  - 2-5. SCREW : NICKEL
- ELECTRICAL SPECIFICATION :
  - 3-1. Rated current : 2A
  - 3-2. Rated voltage : 4PIN 150V AC / 200V DC ;  
5~7PIN 100V AC / 140V DC
- Environmental :
  - 4-1. Operation Temperature : -25℃~85℃

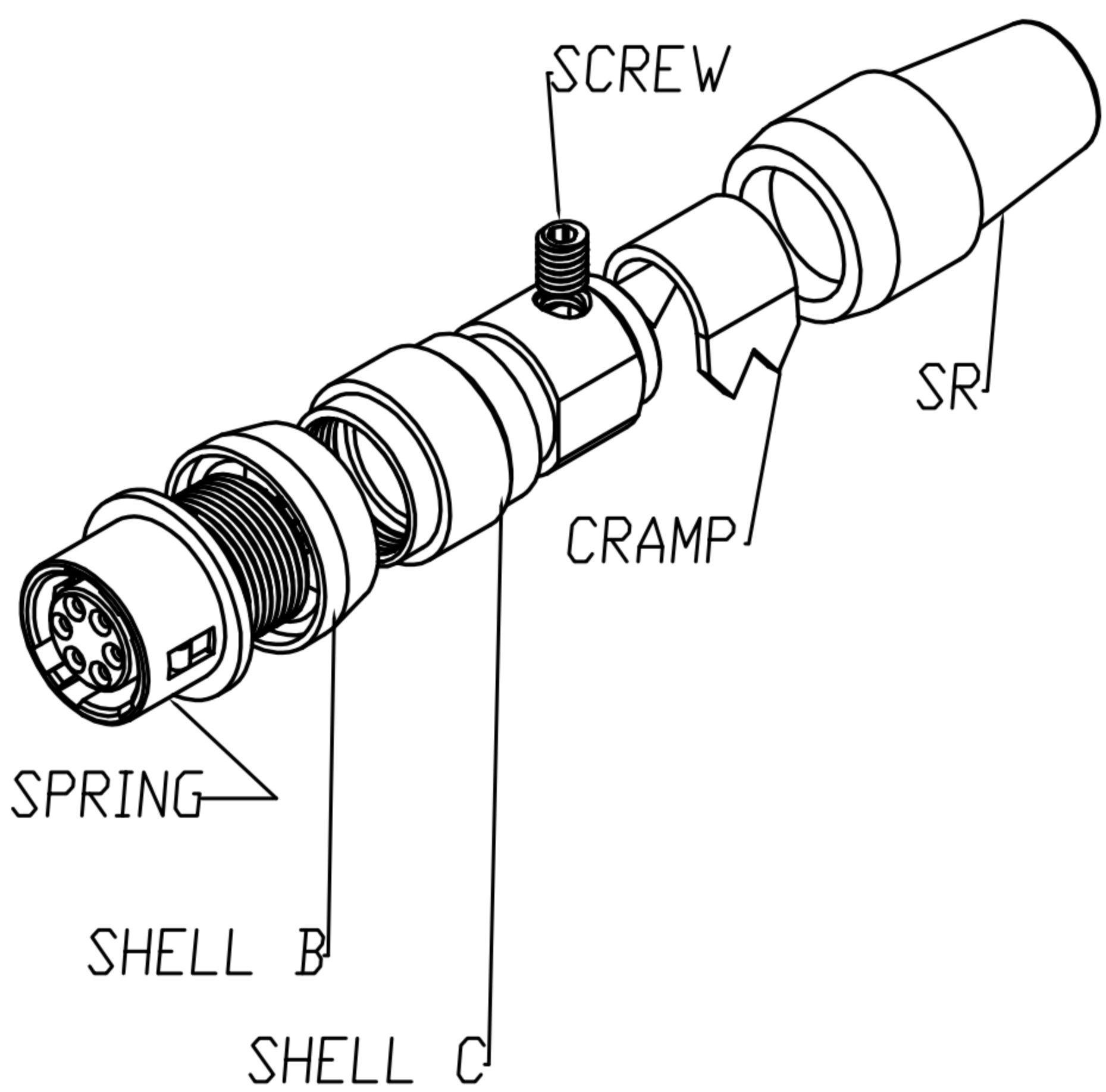

HOUSING + CONTACT + SHELL A + SPRING  
SHELL B  
SHELL C

DRAWN	Mark Kao	APPVL	Ku Chou	UNIT	mm	TOLERANCE		广东科斯达电子科技有限公司 GUANG DONG KE SI DA ELECTRONIC TECHNOLOGY CO., LTD.	TITLE	DIN (F) JACK 插頭式 (SHELL SIZE 7mm)			SHEET	1/2
CHK'D	Emily Suen			SCALE	1:1	.x ±0.20 .xx ±0.10 .xxx ±0.05 .xxxx ±0.03 ANGULA ±1°			PART NO.	SEE TABLE A	DWG NO.	QC5667	VERSION	