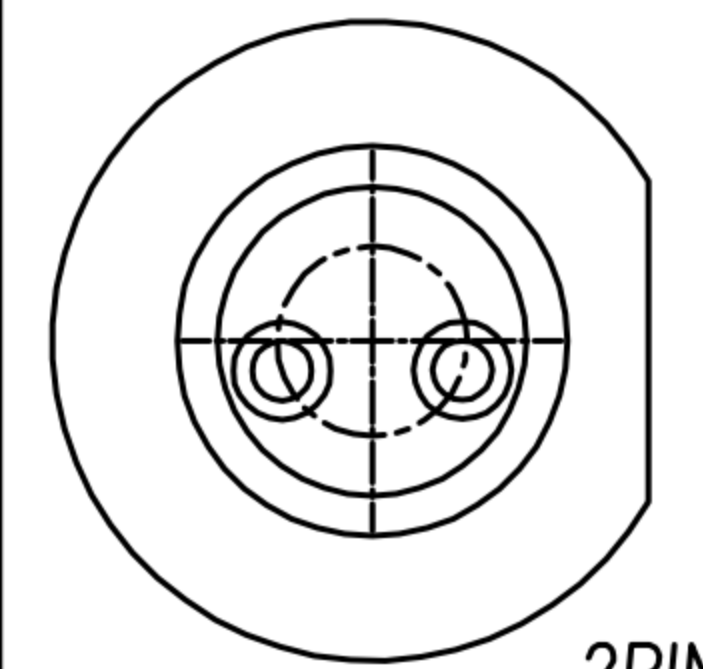
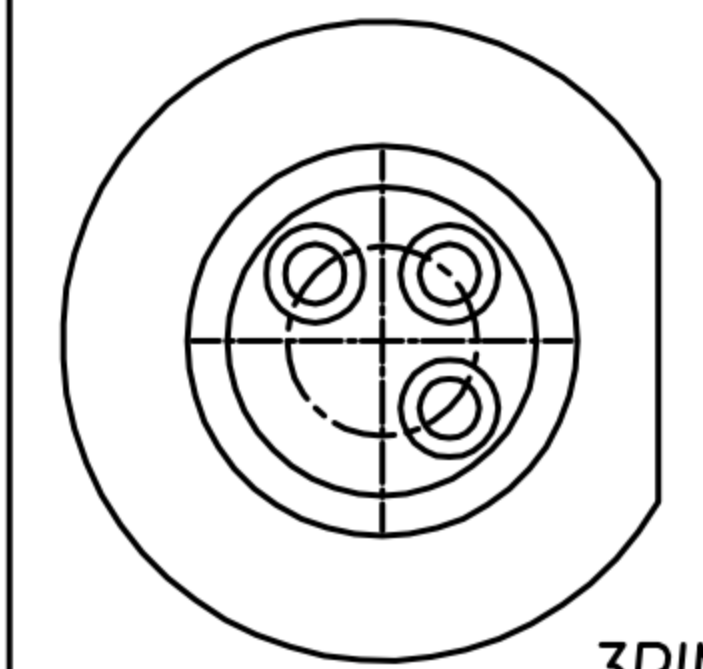
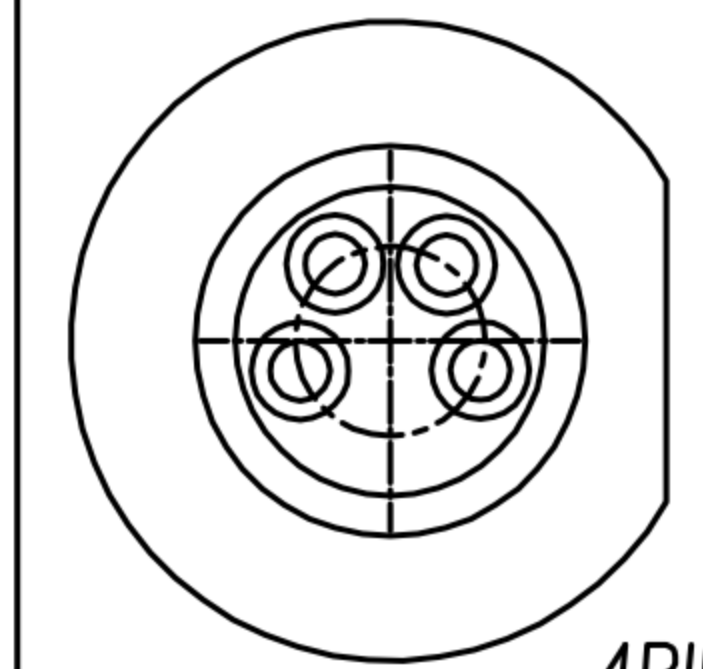

CUSTOMER DRAWING

REV.	DESCRIPTION	APPVL. BY	DATE	ECN NO.
△A	RELEASE	Emily Suen	31/12/10'	
△B				
△C				

TABLE A/表A

		
2PIN	3PIN	4PIN
WP-02F2-11		WP-04F2-61 WP-04F2-74
WP-04F2-74	STAINLESS STEEL 303	
WP-04F2-61	BRASS	
WP-02F2-11	BRASS	
PART NO	NUT & SHELL MATERIAL	

- MATERIAL :
  - HOUSING : PBT UL94V-0 ; COLOR : BLACK
  - CONTACT : BRASS
  - NUT : SEE TABLE A
  - SHELL : SEE TABLE A
  - O-RING-A : NBR ; COLOR : BLACK
  - O-RING-B : EPDM ; COLOR : BLACK
- FINISH :
  - CONTACT : 10 MICRO INCHES MIN. GOLD PLATED  
UNDER PLATE : NICKEL
  - NUT : NICKEL PLATED
  - SHELL : NICKEL PLATED
- ELECTRICAL SPECIFICATION :
  - Rated current : 4A
  - Rated voltage : 60V
  - Water proof : IPX7
- Environmental :
  - Operation Temperature : -20℃~85℃

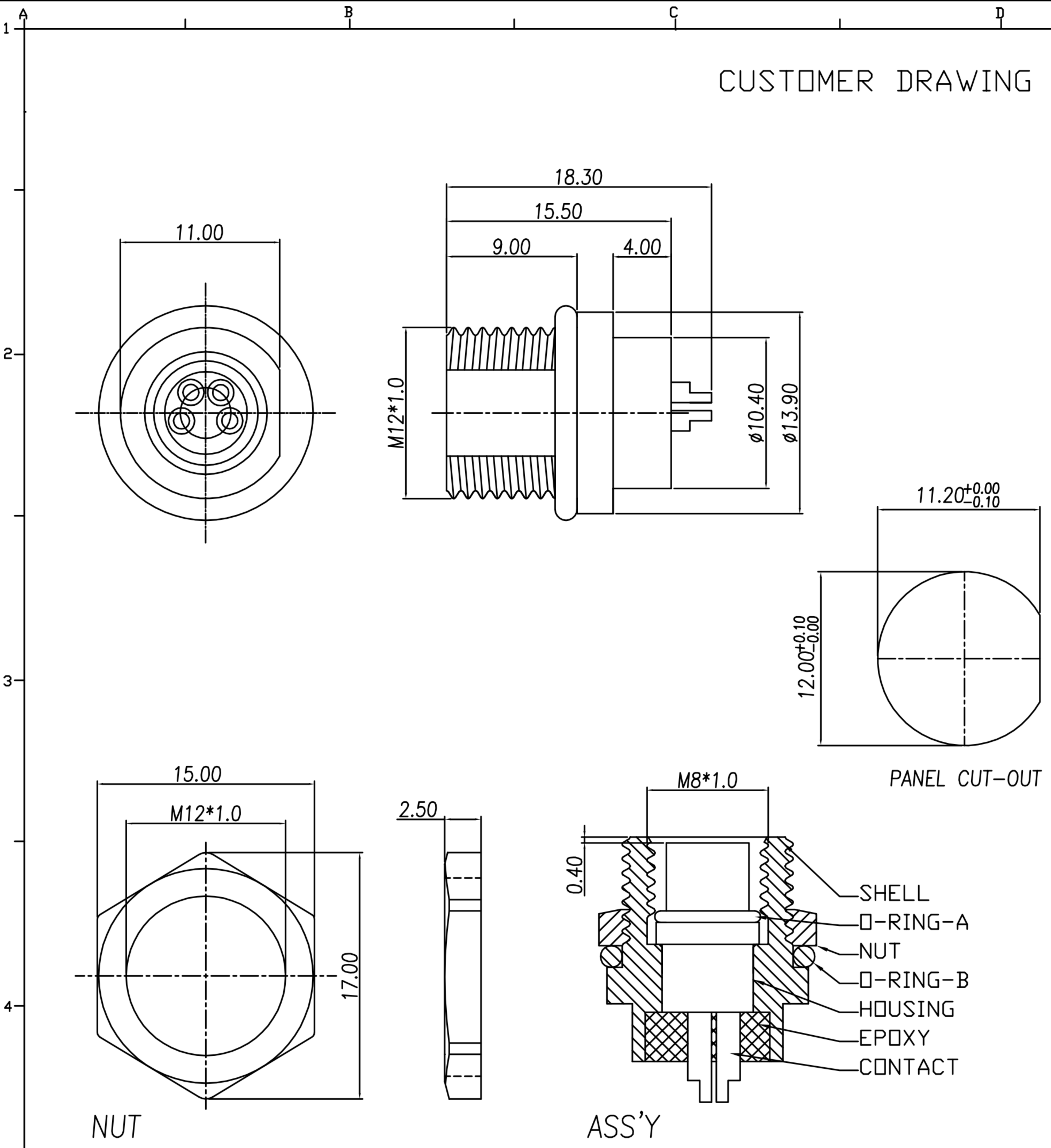

DRAW	Ku Chou	APPVL	Emily Suen	UNIT	mm	TOLERANCE		 广东科斯达电子科技有限公司 GUANG DONG KE SI DA ELECTRONIC TECHNOLOGY CO., LTD.	TITLE	M8-(F)前鎖M12*1.0焊線式			SHEET	1
CHECK	Emily Suen			SCALE	1:1	.x ±0.20 .xx ±0.10 .xxx ±0.05 .xxxx ±0.03 ANGULA ±1°			PART NO.	SEE TABLE A	DWG NO.	QC5171	VERSION	A