

CUSTOMER DRAWING

REV.	DESCRIPTION	APPROVED BY	DATE	ECN NO.
A	RELEASE	Fido Weng	22/03/10'	
B	增加料號		14/01/15'	
C				

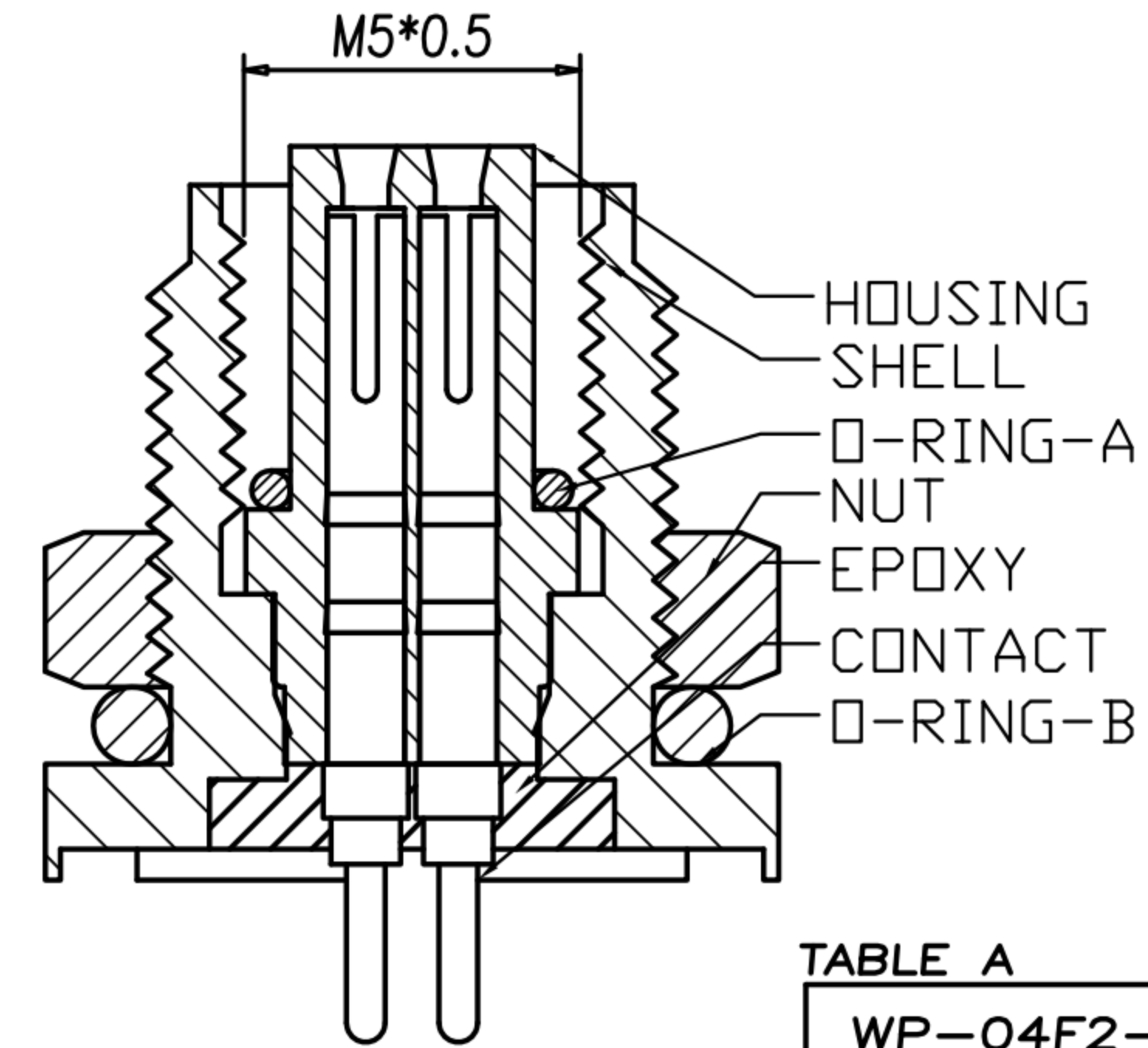
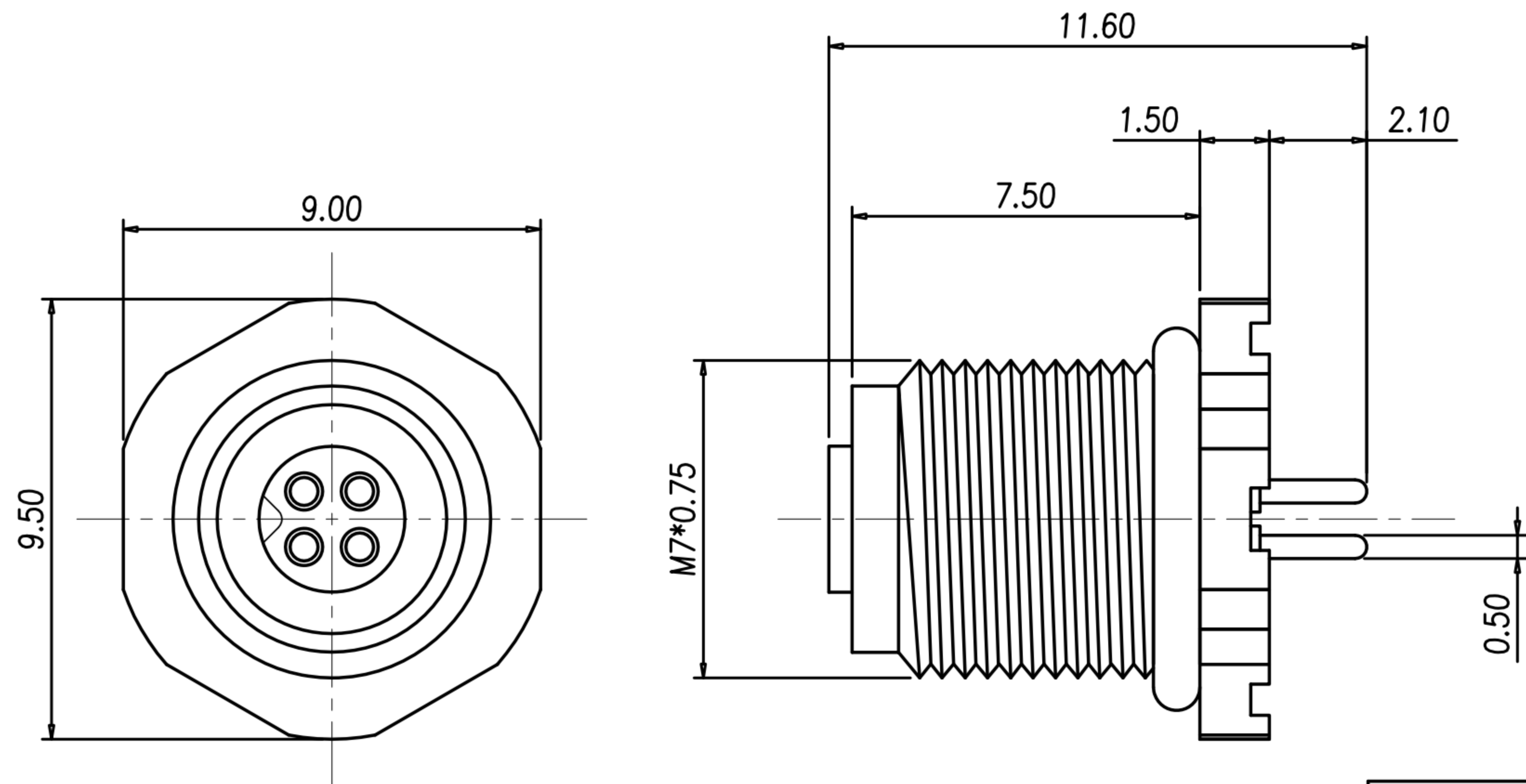
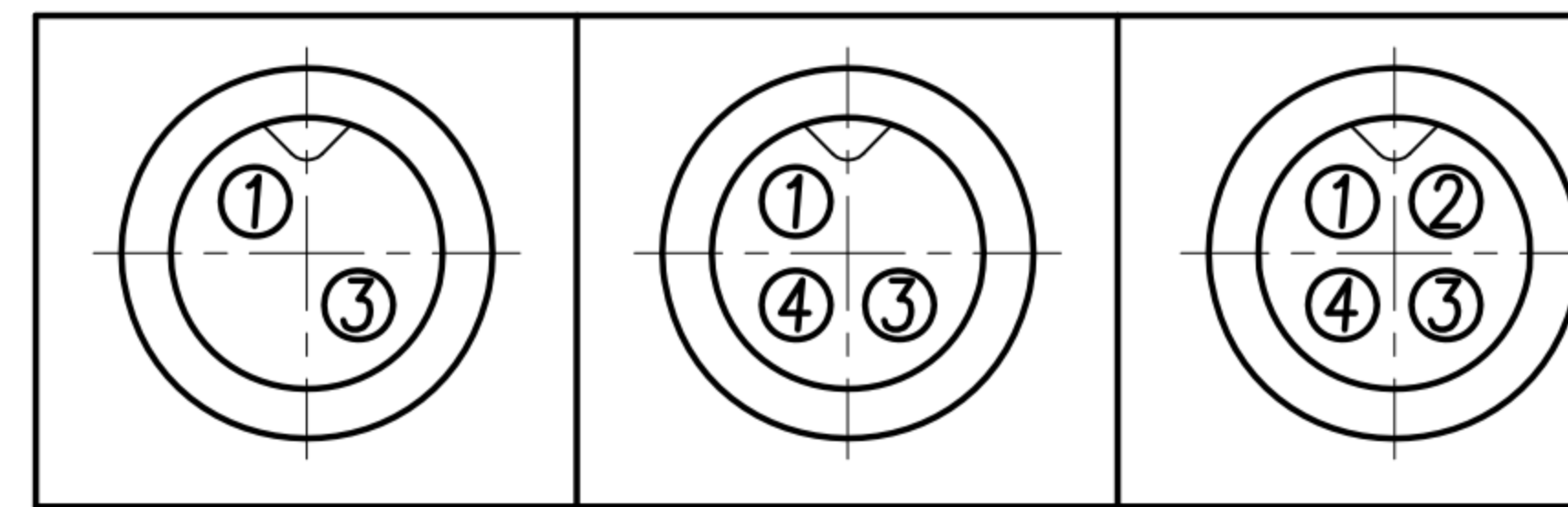
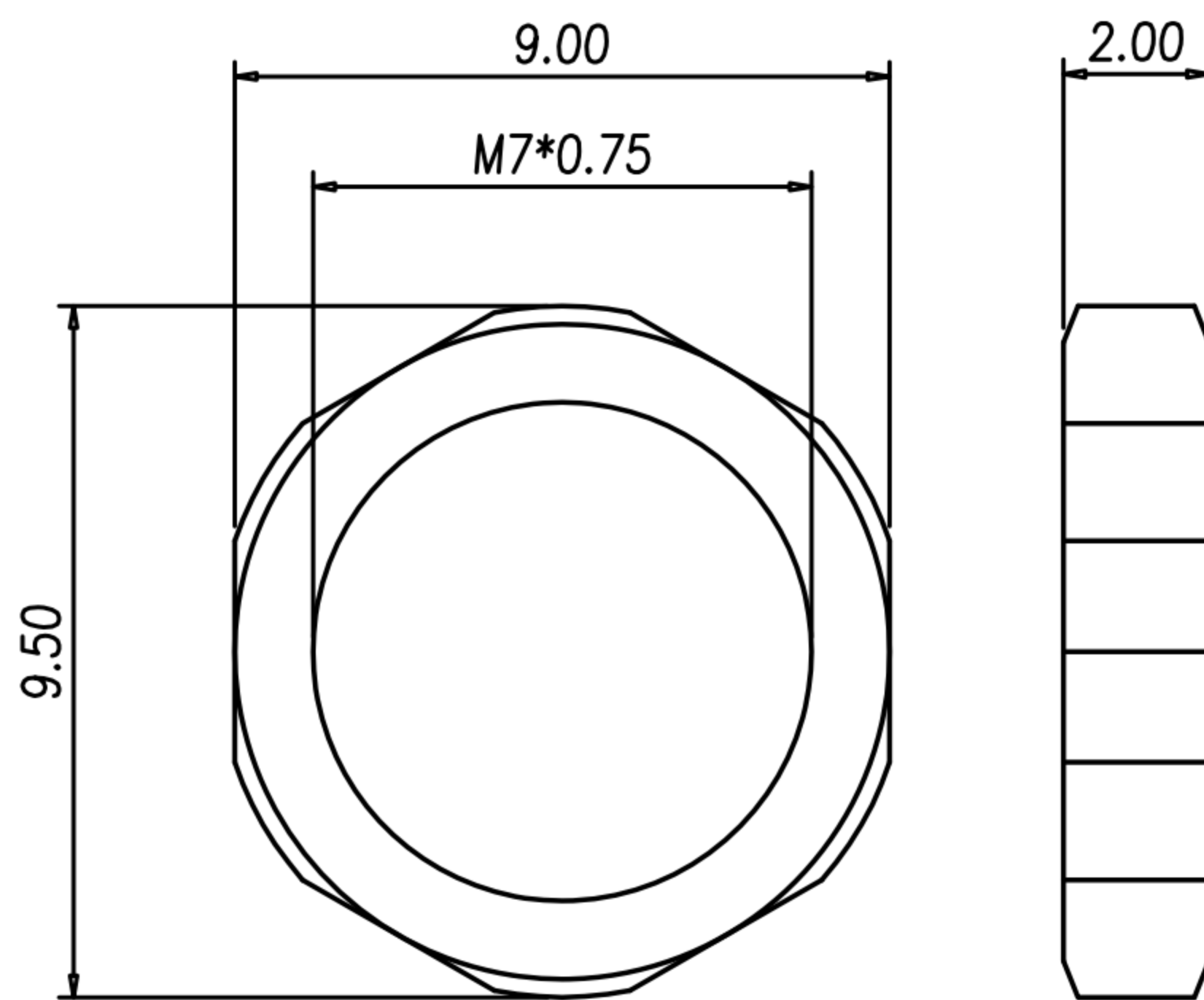

TABLE A

PART NO	FINISH
WP-04F2-146-11	GOLD 10u"
WP-03F2-67-11	GOLD 10u"
WP-02F2-43-11	GOLD 10u"
WP-04F2-51	GOLD FLASH
WP-03F2-50-11	GOLD FLASH
WP-02F2-32-11	GOLD FLASH



- MATERIAL :
  - 1-1. HOUSING : PBT UL94V-0; COLOR : BLACK
  - 1-2. CONTACT : BRASS
  - 1-3. NUT : BRASS
  - 1-4. SHELL : BRASS
  - 1-5. O-RING : NBR ; COLOR : BLACK
  - 1-6. EPOXY BASE : EF400A & EF400B. COLOR : BLACK
- FINISH :
  - 2-1. CONTACT : SEE TABLE A
  - 2-2. NUT : NICKEL PLATED.
  - 2-3. SHELL : NICKEL PLATED.
- ELECTRICAL SPECIFICATION :
  - 3-1. Rated current : 1A
  - 3-2. Rated Voltage : 60V
  - 3-3. Water proof: IP67
- Environmental :
  - 4-1. Operation Temperature : -20 °C~85°C



NUT

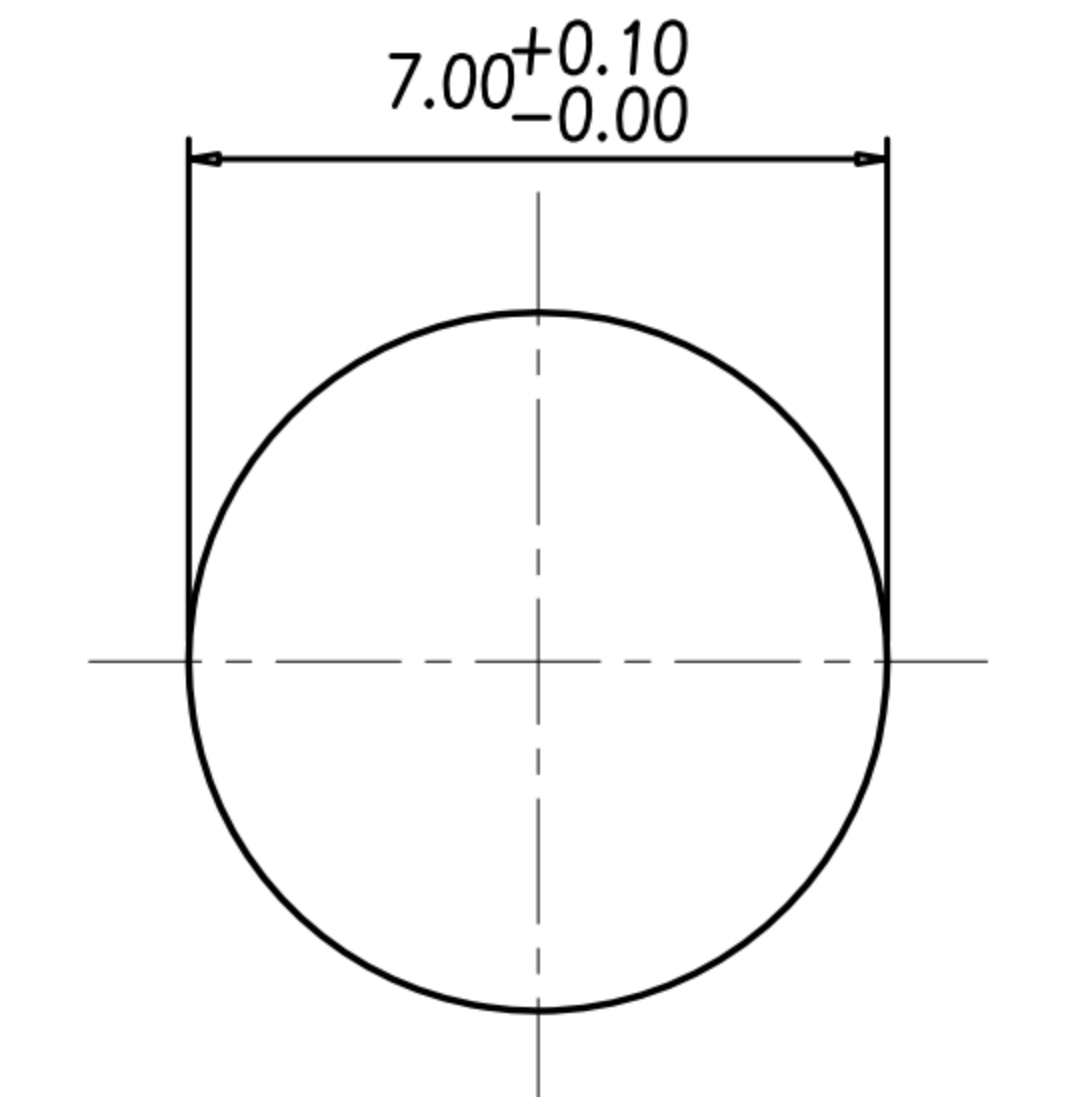

RECOMMEND PANEL CUT-OUT

DRAWN	Mark Kao	APP'D	Ku Chou	UNIT	mm	TOLERANCE			TITLE	M5*0.5 (F) 板端			SHEET	
CHK'D	Emily Suen			SCALE	1:1	.x ±0.20 .xx ±0.10 .xxx ±0.05 .xxxx ±0.03 ANGULA ±1°			PART NO.	SEE TABLE A	DWG NO.	QC4689	VERSION	