

CUSTOMER DRAWING

REV.	DESCRIPTION	APPROVED BY	DATE	ECN NO.
A	RELEASE	Fido Weng	01/10/10'	
B	尺寸變更	Emily Suen	15/08/12'	ECN019
C				

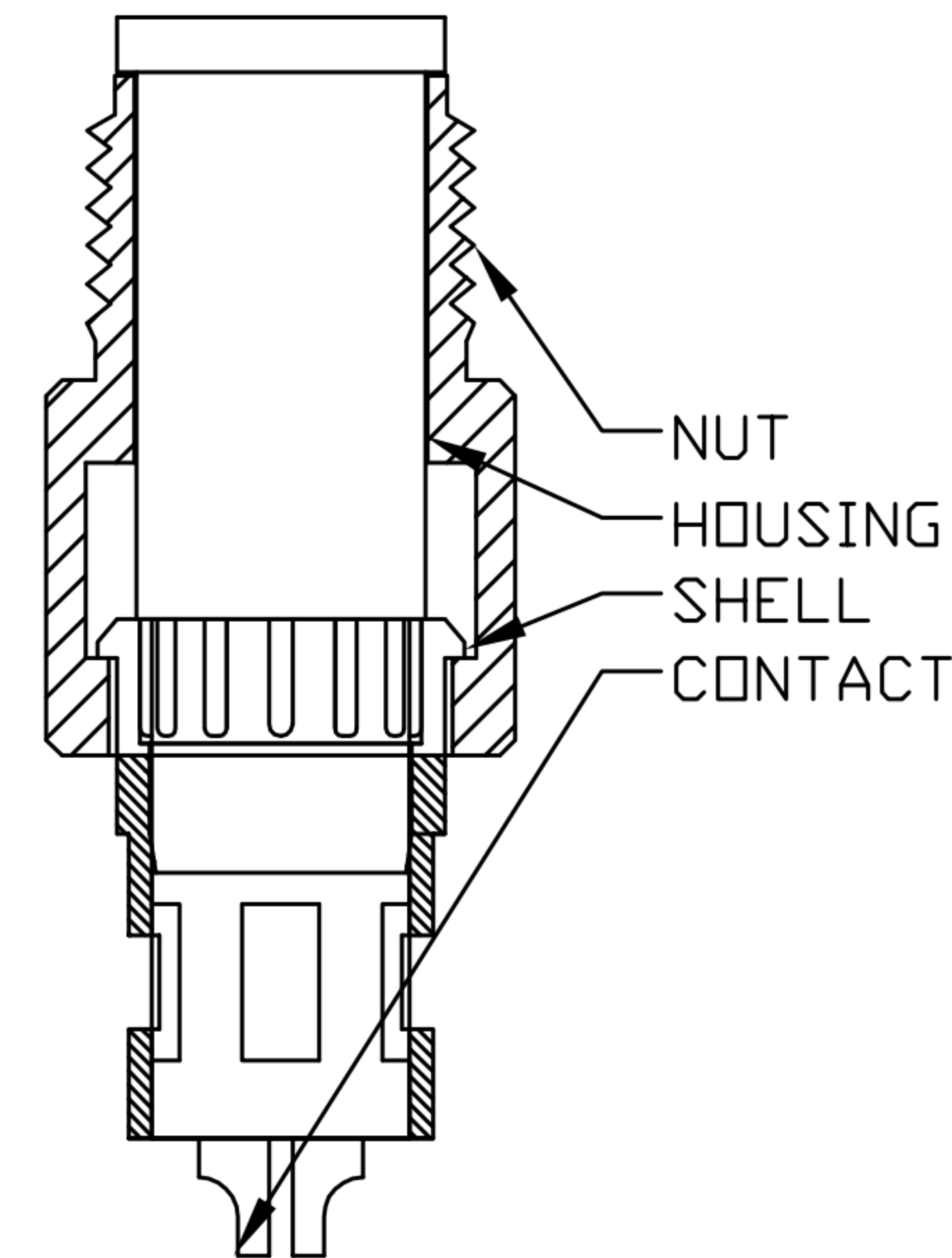
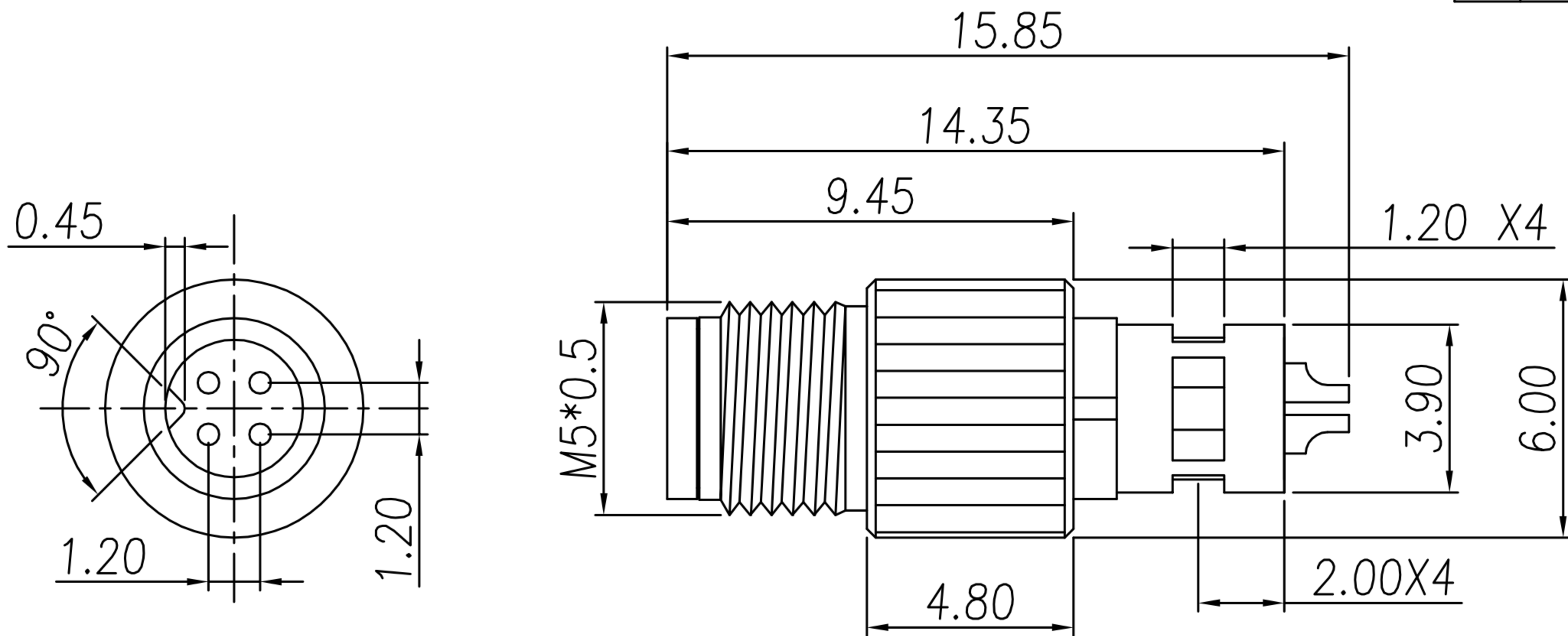

1. MATERIAL :
  - 1-1. HOUSING : SEE TABLE A.
  - 1-2. CONTACT : BRASS.
  - 1-3. NUT : BRASS
  - 1-4. SHELL : BRASS.
2. FINISH :
  - 2-1. CONTACT : GOLD FLISH MICRO INCHES MIN.
  - 2-2. NUT : SEE TABLE A
  - 2-3. SHELL : BRIGHT TIN PLATED .
3. ELECTRICAL SPECIFICATION :
  - 3-1. Rated current : 1A
  - 3-2. Rated Voltage : 60V
  - 3-3. Water proof : IP67
4. Environmental :
  - 4-1. Operation Temperature : -20 °C~85°C

TABLE A

WP-04M2-148-11	TPU ; COLOR : BLACK	GOLD FLASH	BLACK Cr
WP-04M2-114-11	TPU ; COLOR : BLACK	GOLD 10u"	SATING Ni
WP-03M2-57-11	TPU ; COLOR : BLACK	GOLD 10u"	SATING Ni
WP-02M2-38-11	TPU ; COLOR : BLACK	GOLD 10u"	SATING Ni
WP-03M2-50-11	TPU ; COLOR : BLACK	GOLD FLASH	SATING Ni
WP-02M2-36-11	TPU ; COLOR : BLACK	GOLD FLASH	SATING Ni
WP-04M2-47	TPU ; COLOR : BLACK	GOLD FLASH	SATING Ni
WP-04M2-72	PBT ; COLOR : BLACK	GOLD FLASH	SATING Ni
PART NO	MATERIAL(HOUSING)	FINISH(CONTACT)	FINISH(NUT)

