

CUSTOMER DRAWING

REV.	DESCRIPTION	APPROVED BY	DATE	ECN NO.
A	RELEASE	Emily Suen	22/11/11'	
B	CHANGE MATERIAL	Emily Suen	19/09/22'	
C				
D				

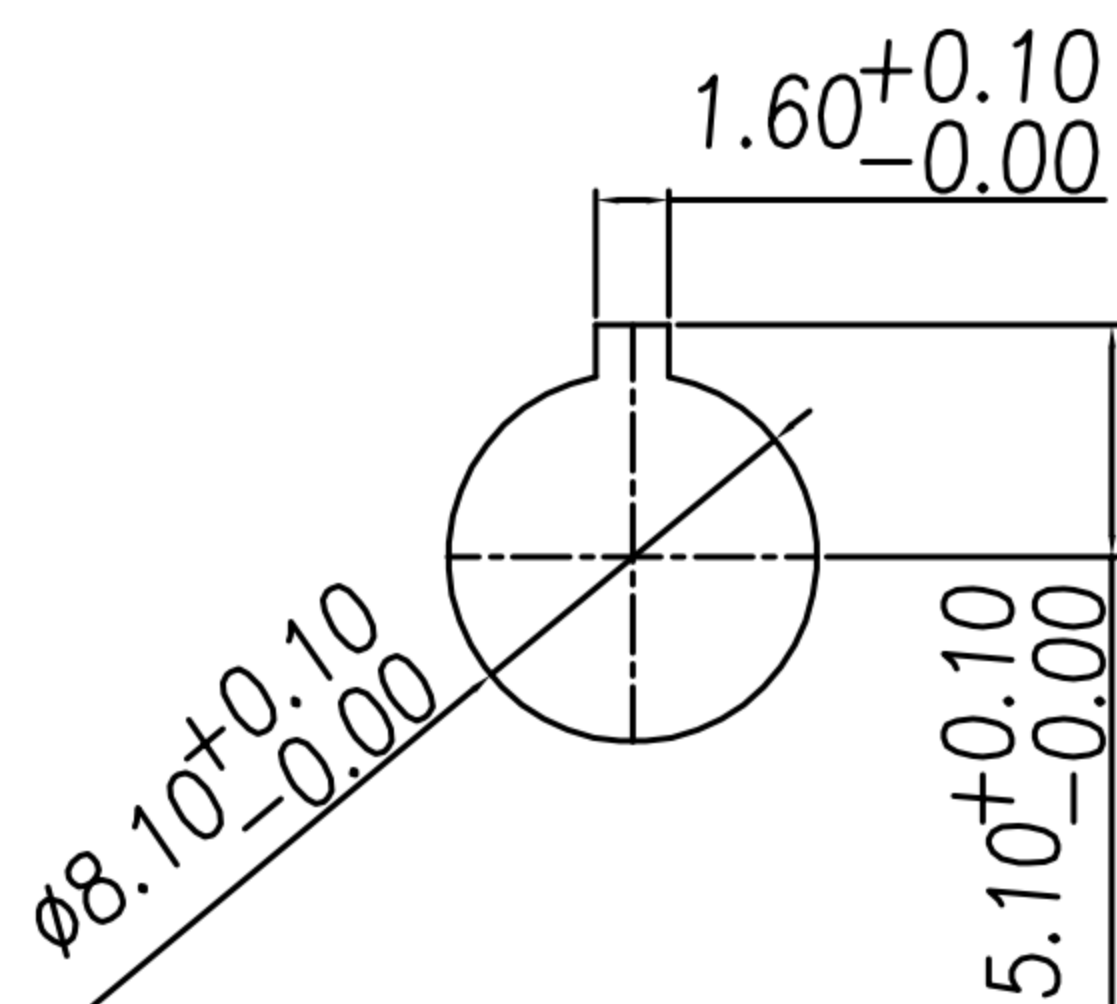

RECOMMENDED MOUNTING HOLE
(Panel thickness 0.7~2)

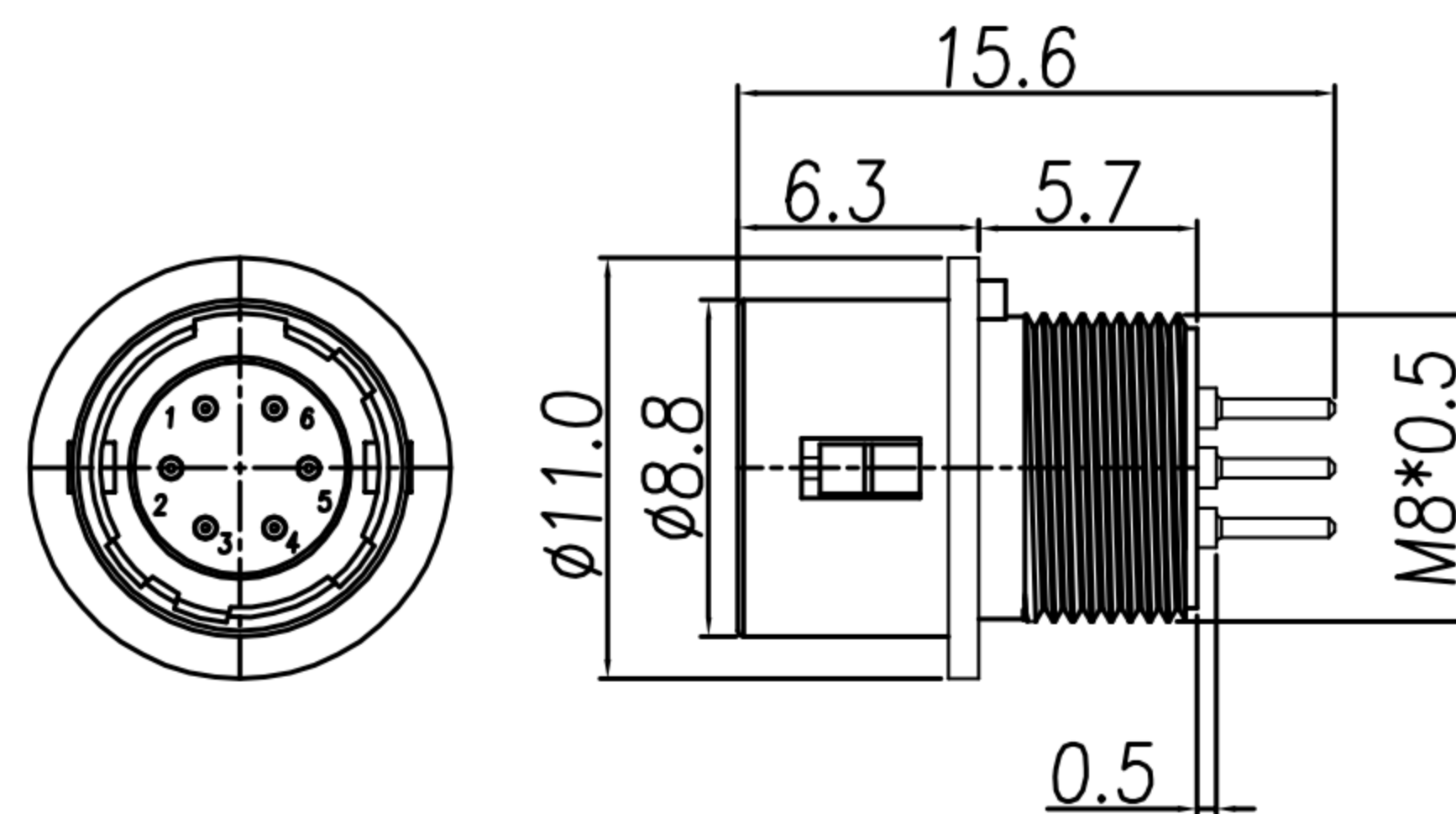

- MATERIAL :
 - 1-1. HOUSING : NYLON66 UL94V-0; COLOR : BLACK
 - 1-2. CONTACT : BRASS
 - 1-3. SHELL : ZINC ALLOY
 - 1-4. SPRING : STAINLESS STEEL
 - 1-5. WASHER : PHOSPHOR BRONZE
 - 1-6. NUT : BRASS
- FINISH :
 - 2-1. CONTACT : GOLD FLASH
 - 2-2. SHELL : NICKEL
 - 2-3. WASHER : NICKEL
 - 2-4. NUT : NICKEL
- ELECTRICAL SPECIFICATION :
 - 3-1. Rated current : 2A
 - 3-2. Rated voltage : 4PIN 150V AC / 200V DC ;
5~7PIN 100V AC / 140V DC
- Environmental :
 - 4-1. Operation Temperature : -25℃~85℃

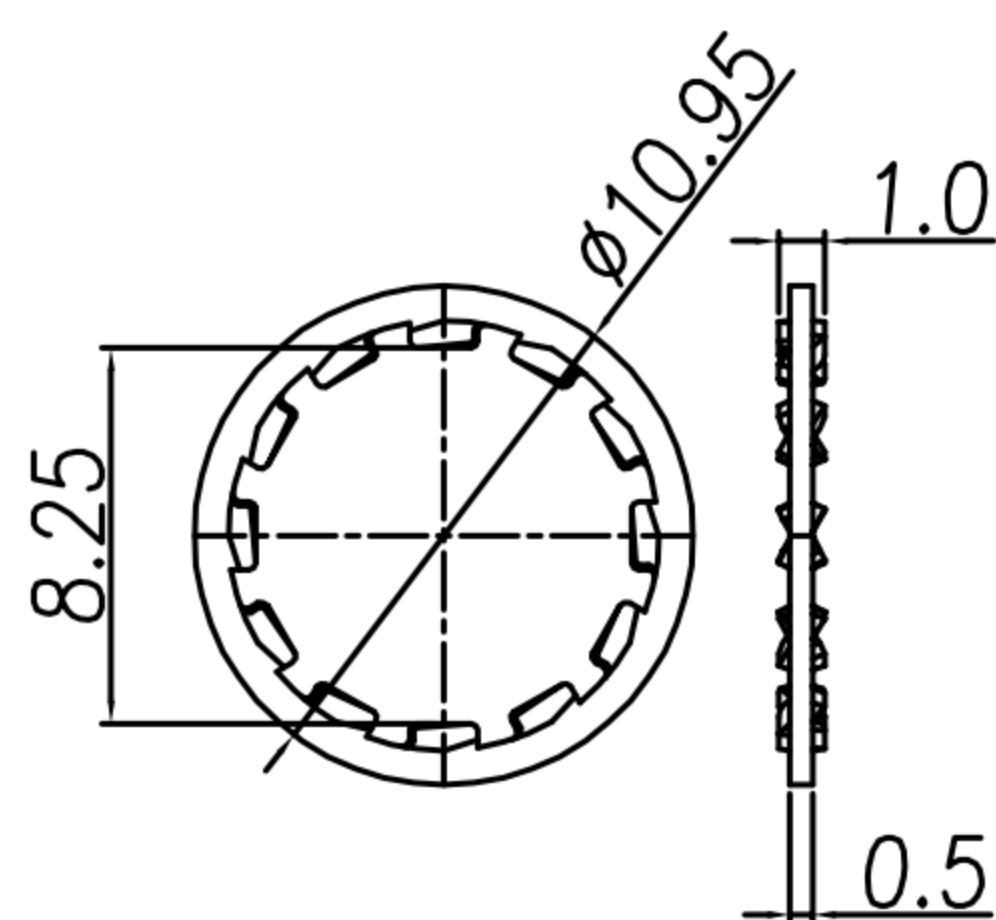

WASHER

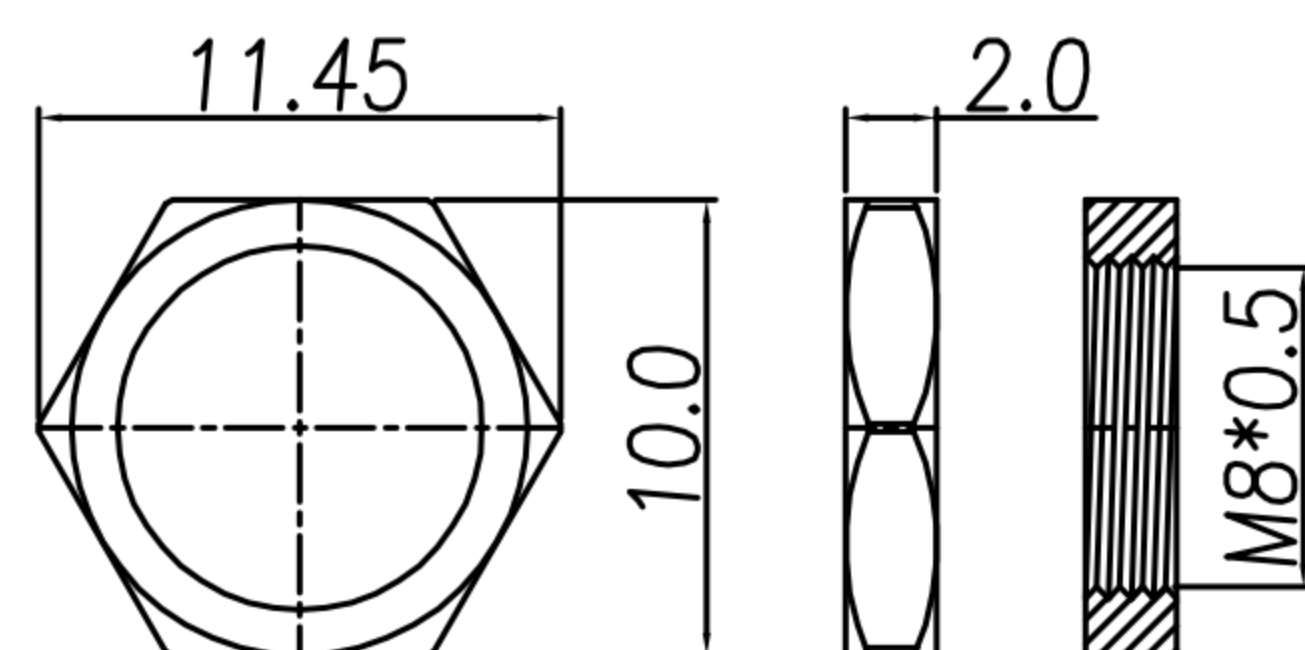

NUT

TABLE A

CONTACT ARRANGEMENT(FRONT VIEW)			
DI-04M3-02	DI-05M3-01	DI-06M3-02	DI-07M3-01

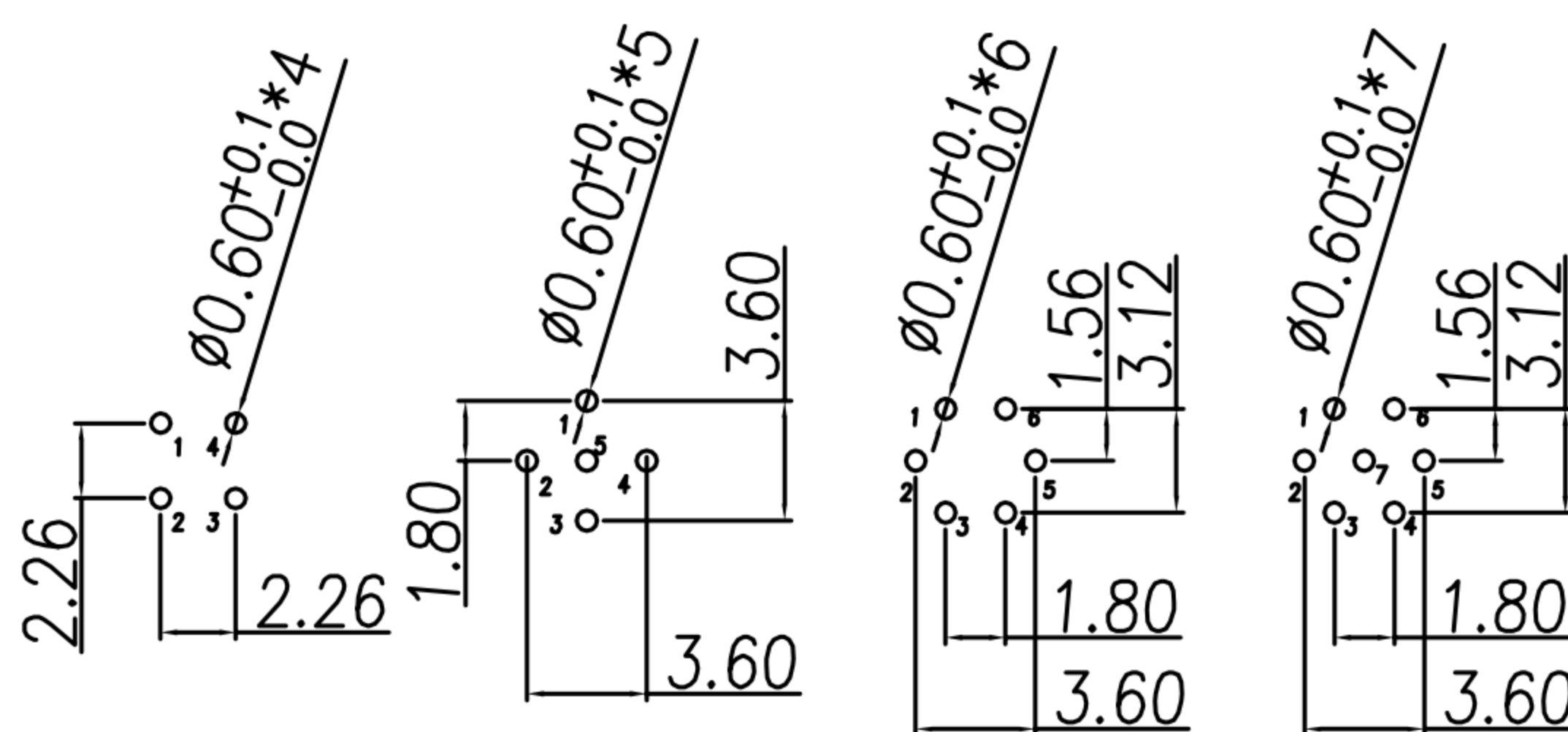

RECOMMEND P.C.B LAYOUT

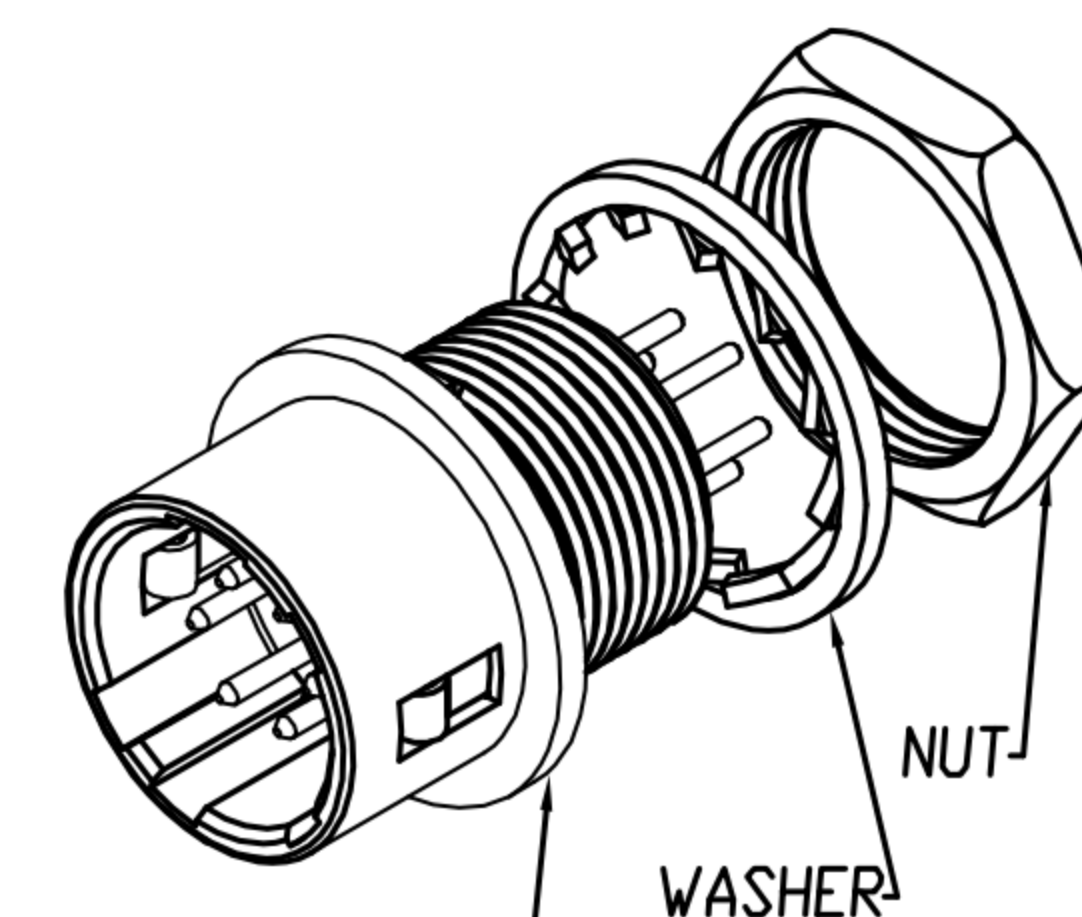

HOUSING+CONTACT+SPRING+SHELL

DRAWN	Ku Chou	APPV'L	Emily Suen	UNIT	mm	TOLERANCE		广东科斯达电子科技有限公司 GUANG DONG KE SI DA ELECTRONIC TECHNOLOGY CO., LTD.	TITLE	DIN (M) RECEPTACLE 鑰板/插件式(SHELL SIZE 7mm)			SHEET
CHK'D	Emily Suen			SCALE	1:1	.x ±0.20 .xx ±0.10 .xxx ±0.05 .xxxx ±0.03 ANGULA ±1°			PART NO.	SEE TABLE A	DWG NO.	QC5668	VERSION