

CUSTOMER DRAWING

REV.	DESCRIPTION	APPVL. BY	DATE	ECN NO.
△A	RELEASE	Fido Weng	13/10/16'	
△B				
△C				

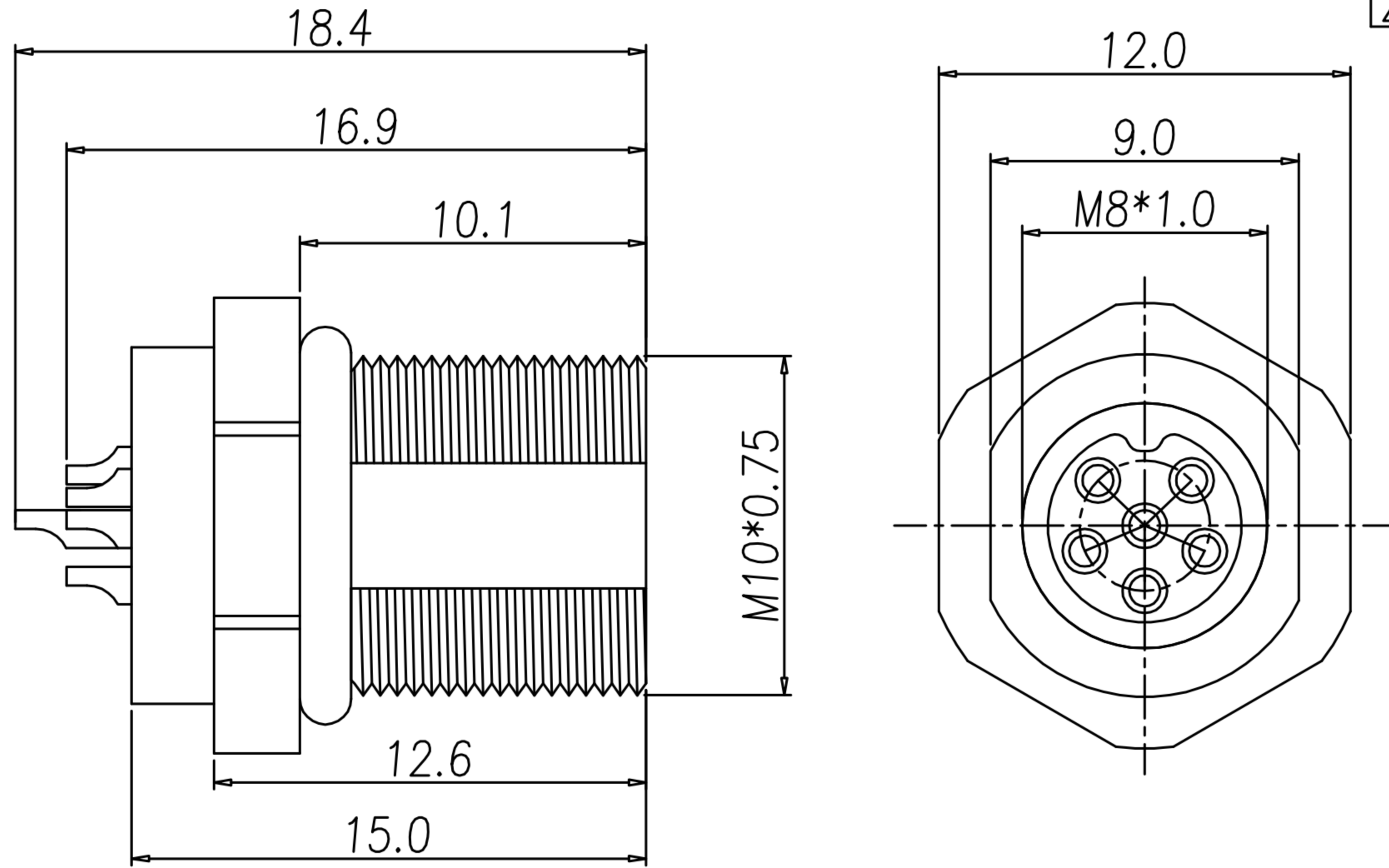
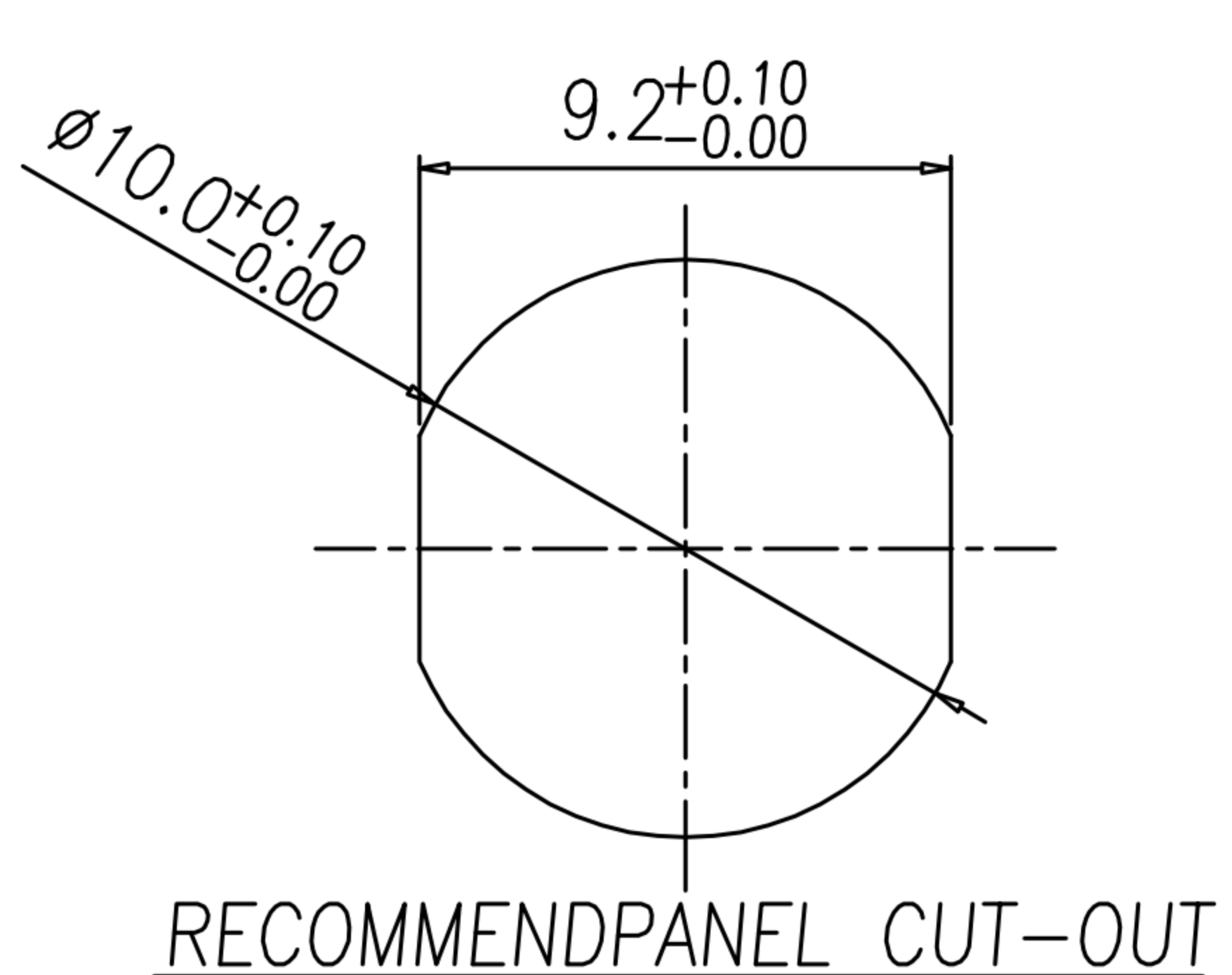
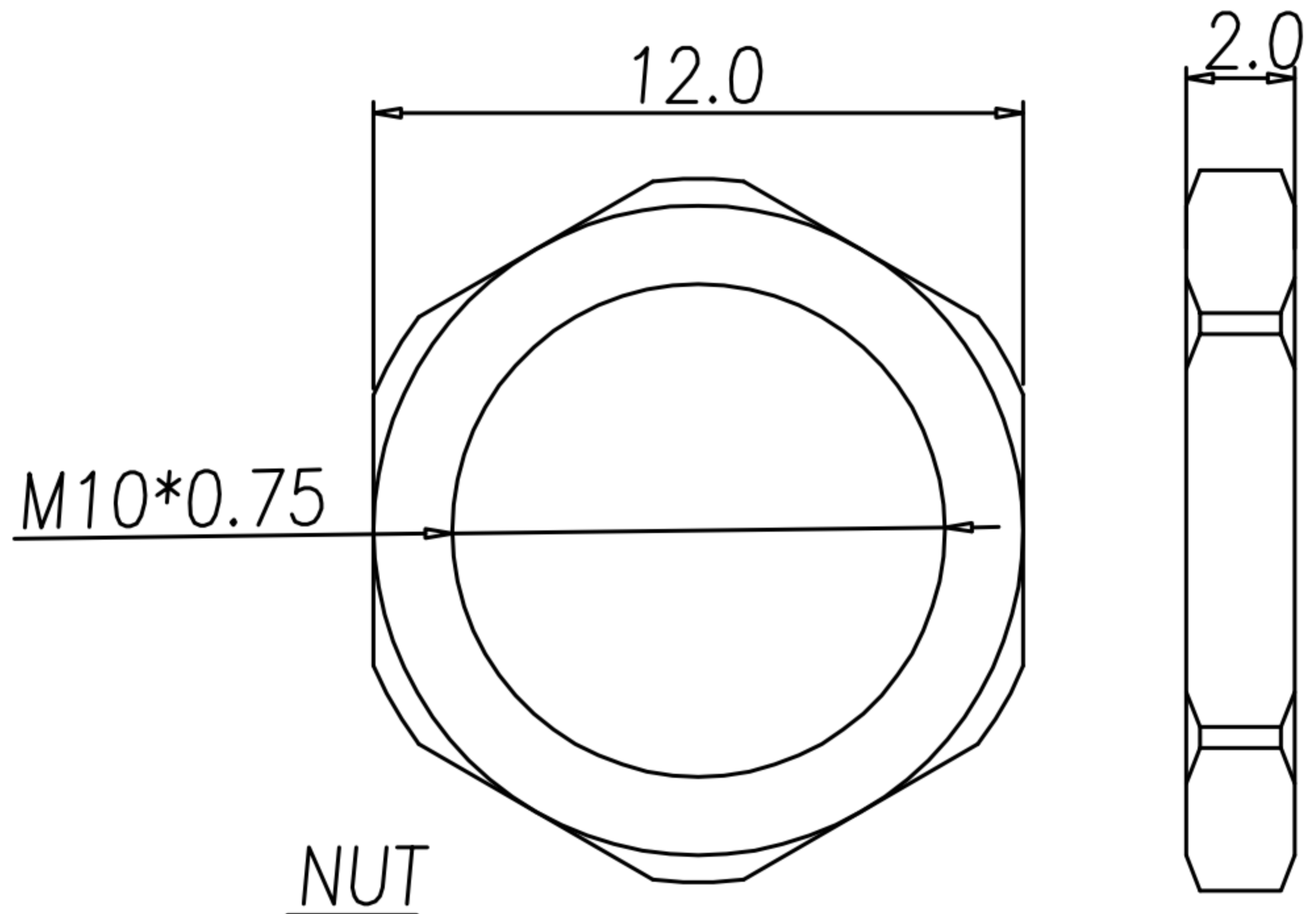

TABLE A

WP-06F2-58-11	WP-05F2-140-11



NOTE:

- MATERIAL :
 - 1-1. HOUSING : PA66 ; COLOR : BLACK
 - 1-2. CONTACT : BRASS.
 - 1-3. SHELL : BRASS.
 - 1-4. NUT : BRASS.
 - 1-5. O-RING : EPDM ; COLOR : BLACK
- FINISH :
 - 2-1. CONTACT : GOLD FLASH.
 - 2-2. SHELL : NICKEL PLATED.
 - 2-3. NUT : NICKEL PLATED.
- ELECTRICAL SPECIFICATION :
 - 3-1. Rated current : 2A
 - 3-2. Rated Voltage : 30V
 - 3-3. Water proof : IP67
- Environmental :
 - 4-1. Operation Temperature : -40℃~105℃

DRAW	KU	APPVL	UNIT	mm	TOLERANCE	广东科斯达电子科技有限公司 GUANG DONG KE SI DA ELECTRONIC TECHNOLOGY CO., LTD.	TITLE	M8 (F) 前鎖焊線式			SHEET
CHECK			SCALE	1:1	.x ±0.20 .xx ±0.10 .xxx ±0.05 .xxxx ±0.03 ANGULA ±1°		PART NO.	SEE TABLE A	DWG NO.	QC8226	VERSION