

CUSTOMER DRAWING

REV.	DESCRIPTION	APPROVED BY	DATE	ECN NO.
A	RELEASE	LEO	11/11/21*	
B				
C				
D				

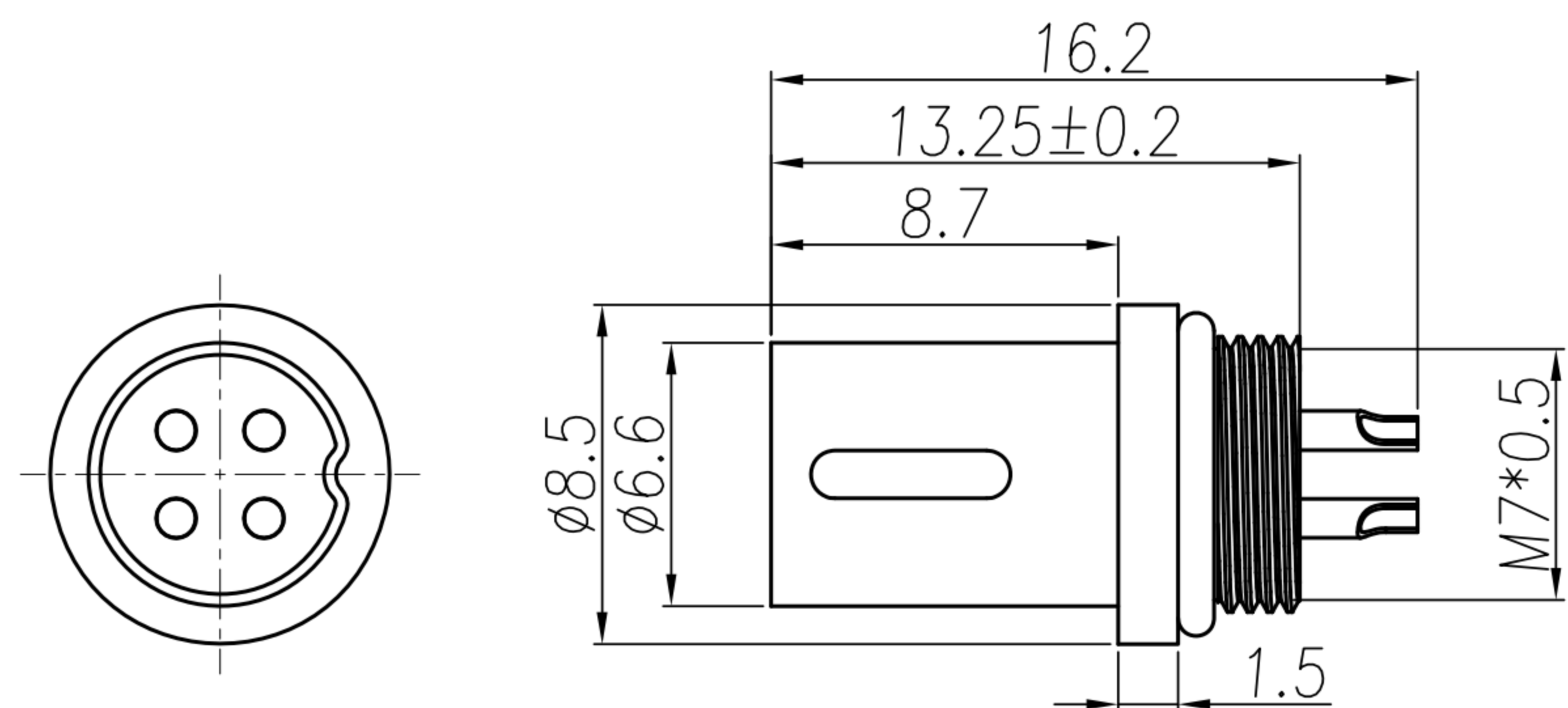

HOUSING & SHELL & CONTACT

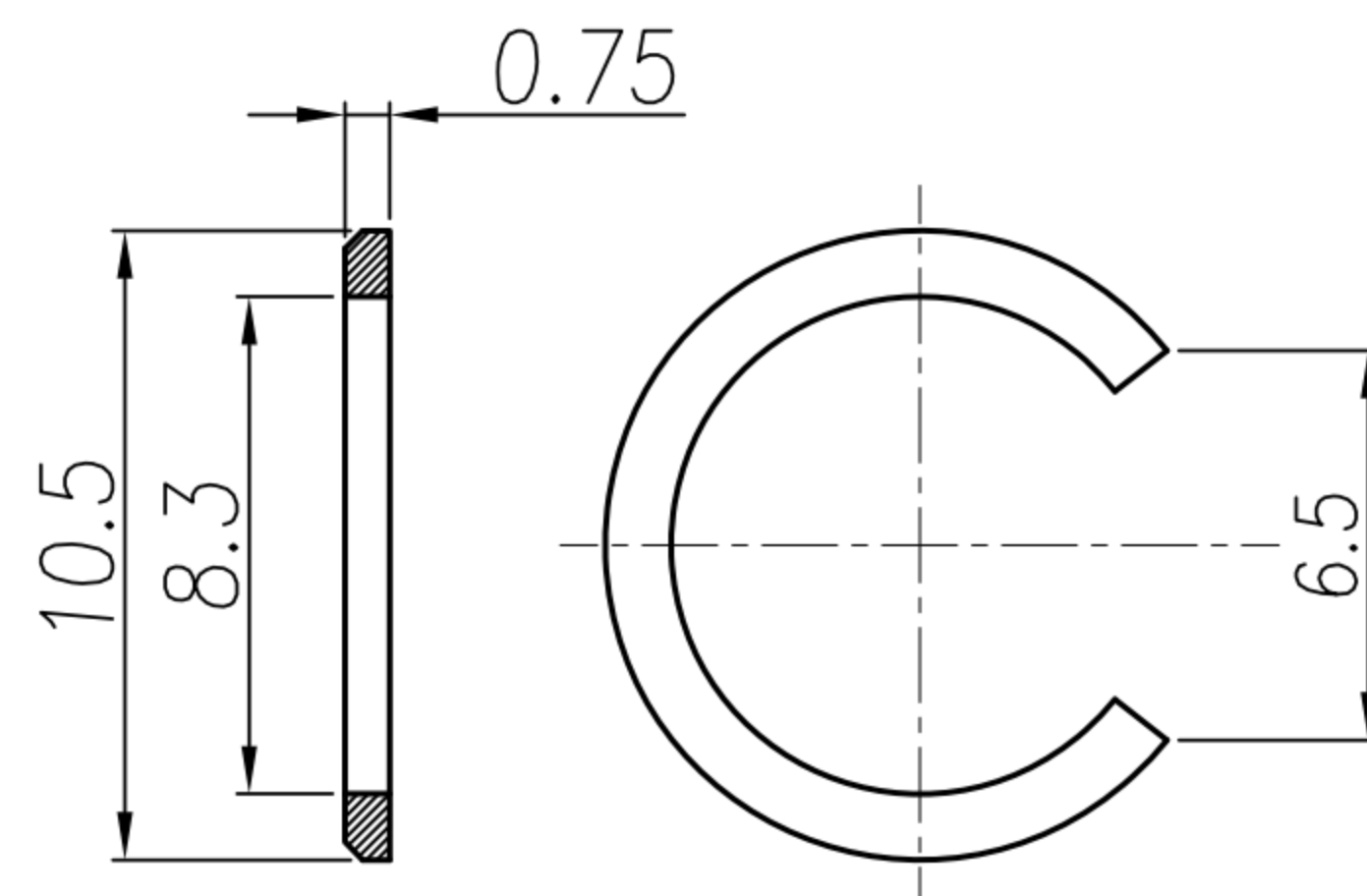

SPRING

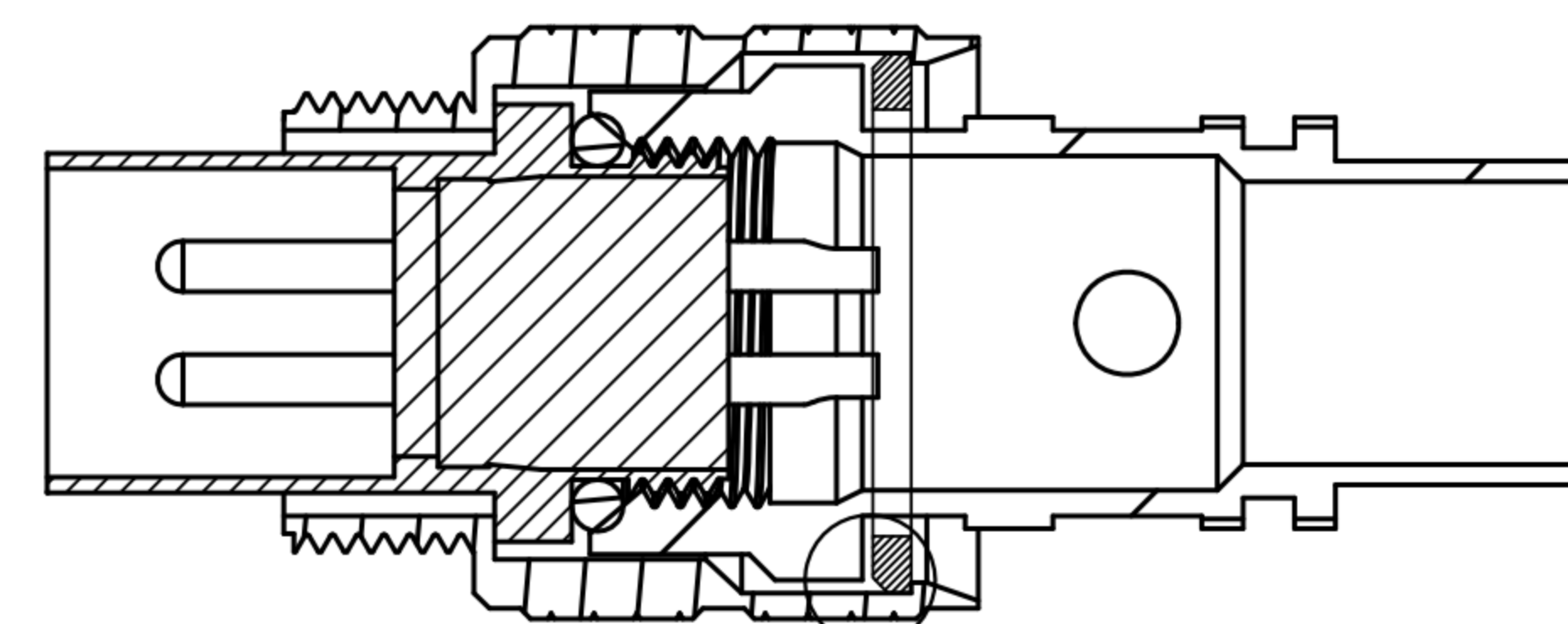

ASS'Y

將不鏽鋼環穿入到這個位置
(倒角朝對插口面)

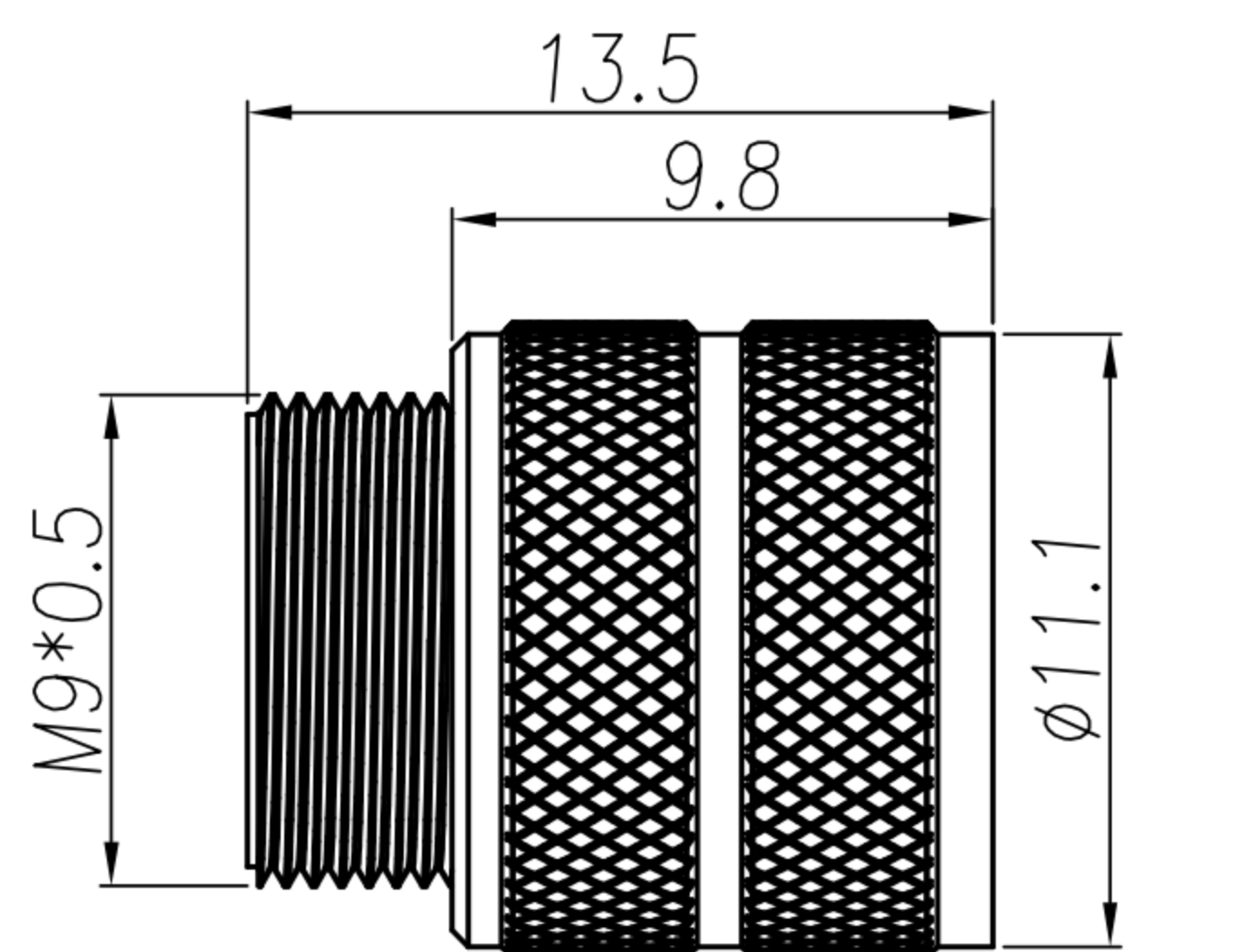

NUT

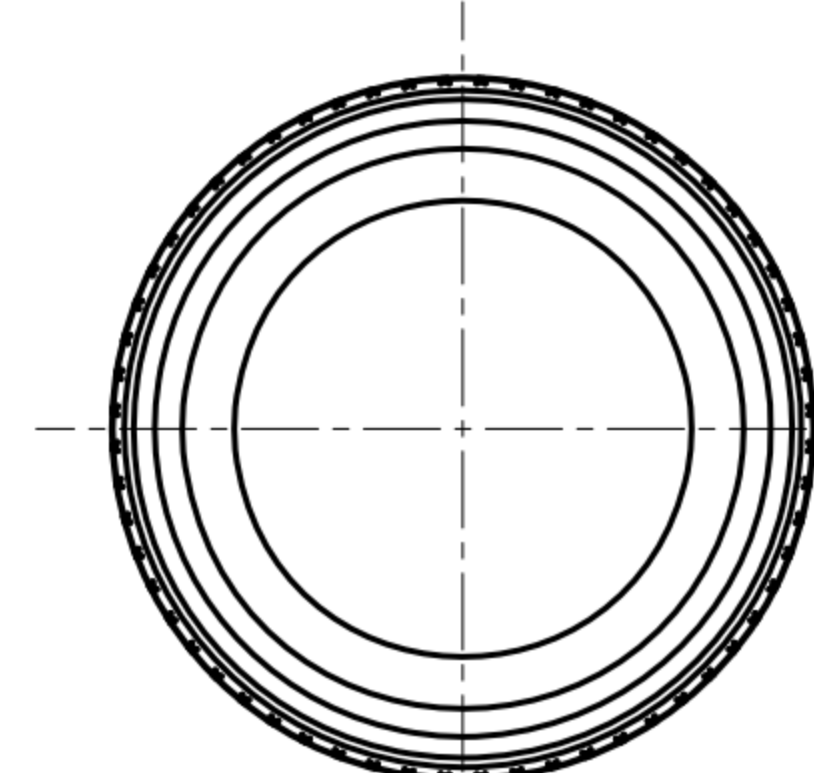

SHELL 2

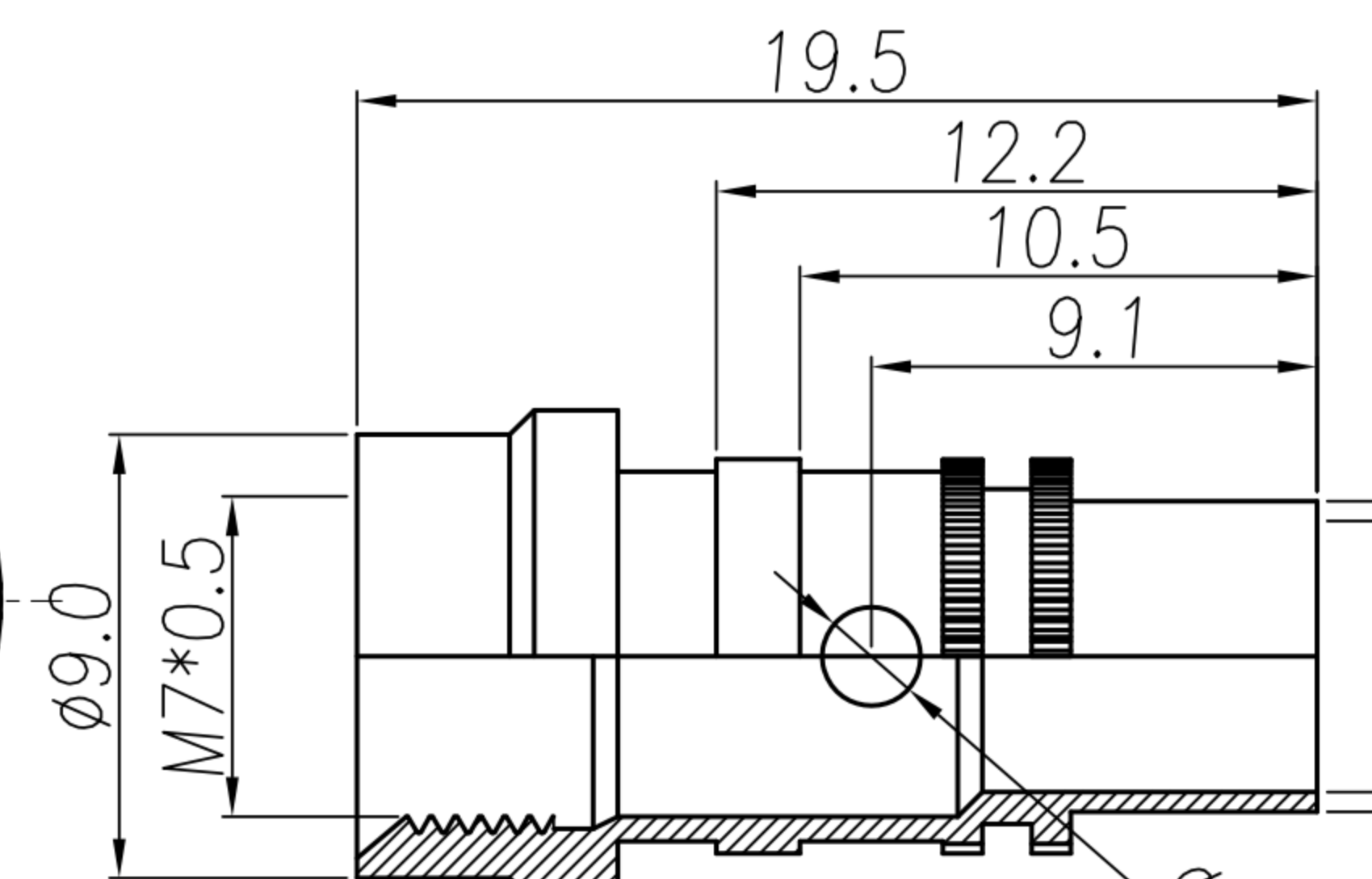

- MATERIAL :
 - 1-1. HOUSING : PA UL94V-0 ; COLOR : BLACK
 - 1-2. CONTACT : BRASS.
 - 1-3. NUT : BRASS.
 - 1-4. SHELL : BRASS.
 - 1-5. SHELL 2 : BRASS.
 - 1-6. SPRING : STAINLESS STEEL.
 - 1-7. O-RING : EPDM ; COLOR : BLACK.
- FINISH :
 - 2-1. CONTACT : GOLD FLASH
 - 2-2. NUT : NICKEL PLATED OVER ALL
 - 2-3. SHELL : NICKEL PLATED OVER ALL
 - 2-4. SHELL 2 : NICKEL PLATED OVER ALL
- ELECTRICAL SPECIFICATION :
 - 3-1. Rated current(40°C) : 2~3P 4A; 4~5P 3A; 7~8P 1A
 - 3-2. Rated voltage : 125V
 - 3-3. Water proof : IP67
- Environmental :
 - 4-1. Operation Temperature : -25°C~70°C

TABLE A/表A

D1=Ø6.3 D2=Ø5.5	D1=Ø5.3 D2=Ø4.5	WP-02M2-81-11	WP-03M2-136-11	WP-04M2-230-11	WP-05M2-191-11	WP-07M2-24-11	WP-08M2-122-11
		WP-02M2-82-11	WP-03M2-137-11	WP-04M2-231-11	WP-05M2-192-11	WP-07M2-25-11	WP-08M2-123-11

DRAWN	LEO	APPEND	Emily Suen	UNIT	mm	TOLERANCE				TITLE	M9 (M) 線端成型式 (接地銅管)			SHEET	
CHK'D	Emily Suen			SCALE	1:1					PART NO.	SEE TABLE A	DWG NO.	QC10293	VERSION	