

CUSTOMER DRAWING

REV.	DESCRIPTION	APPROVED BY	DATE	ECN NO.
A	RELEASE	Fido Weng	04/03/10'	
B				
C				

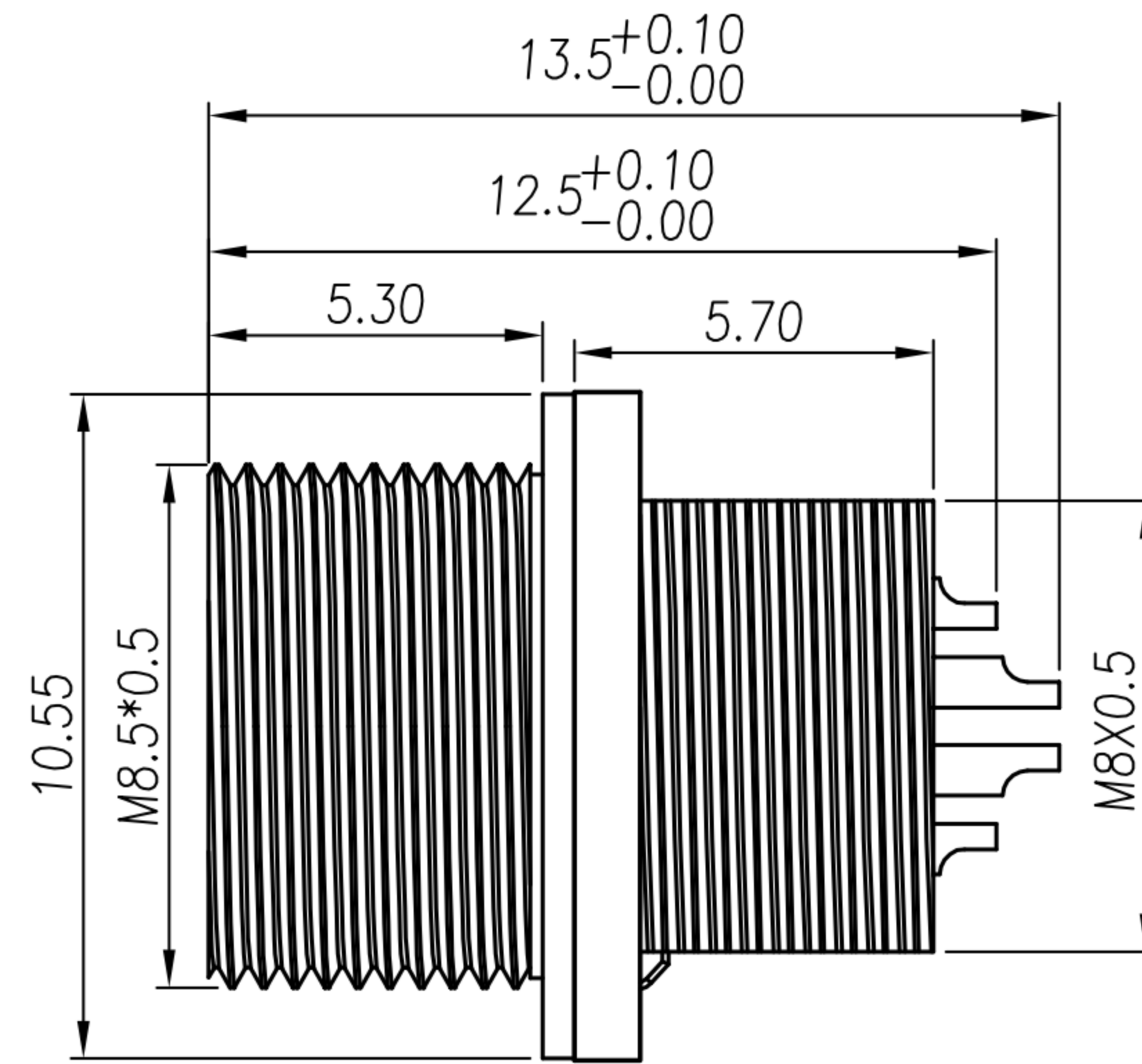

HOUSING+CONTACT+SHELL+O-RING

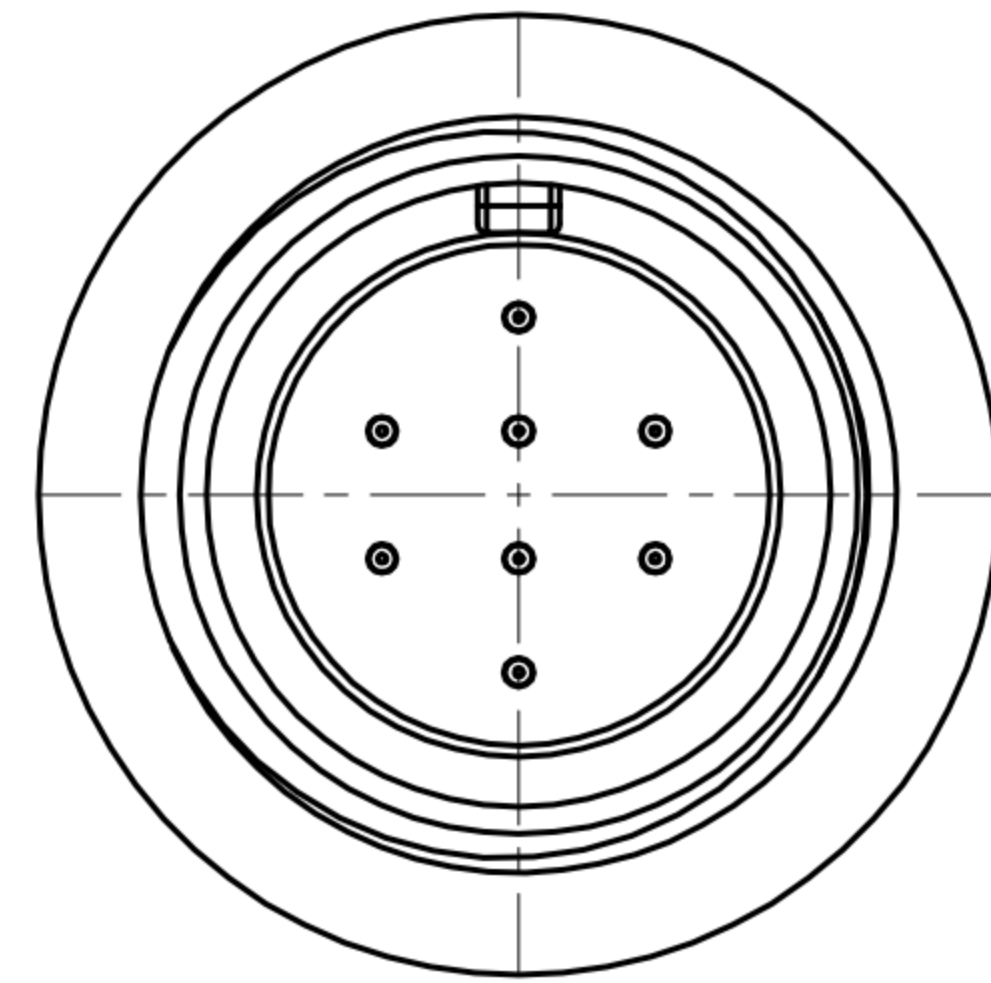
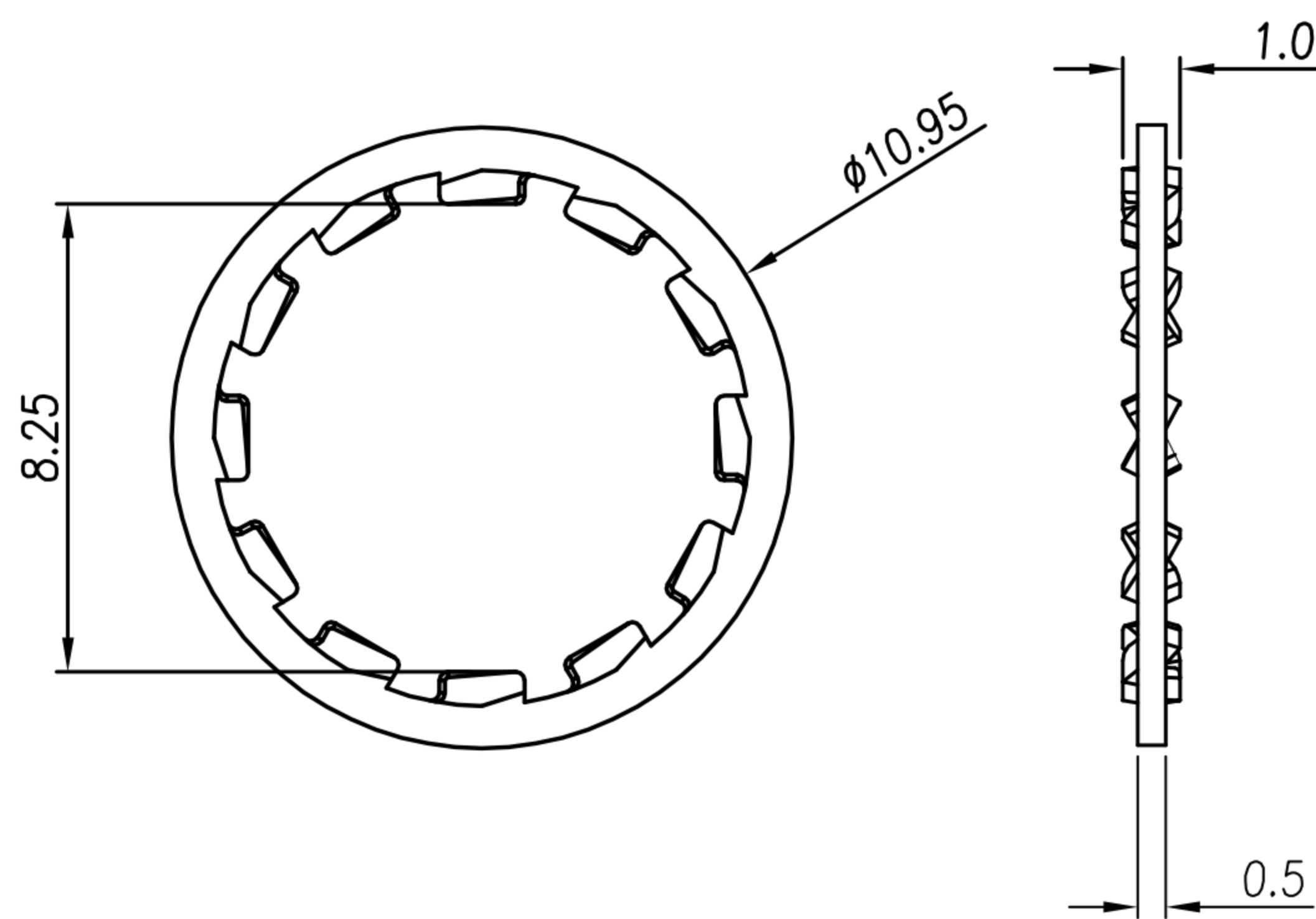

WASHER

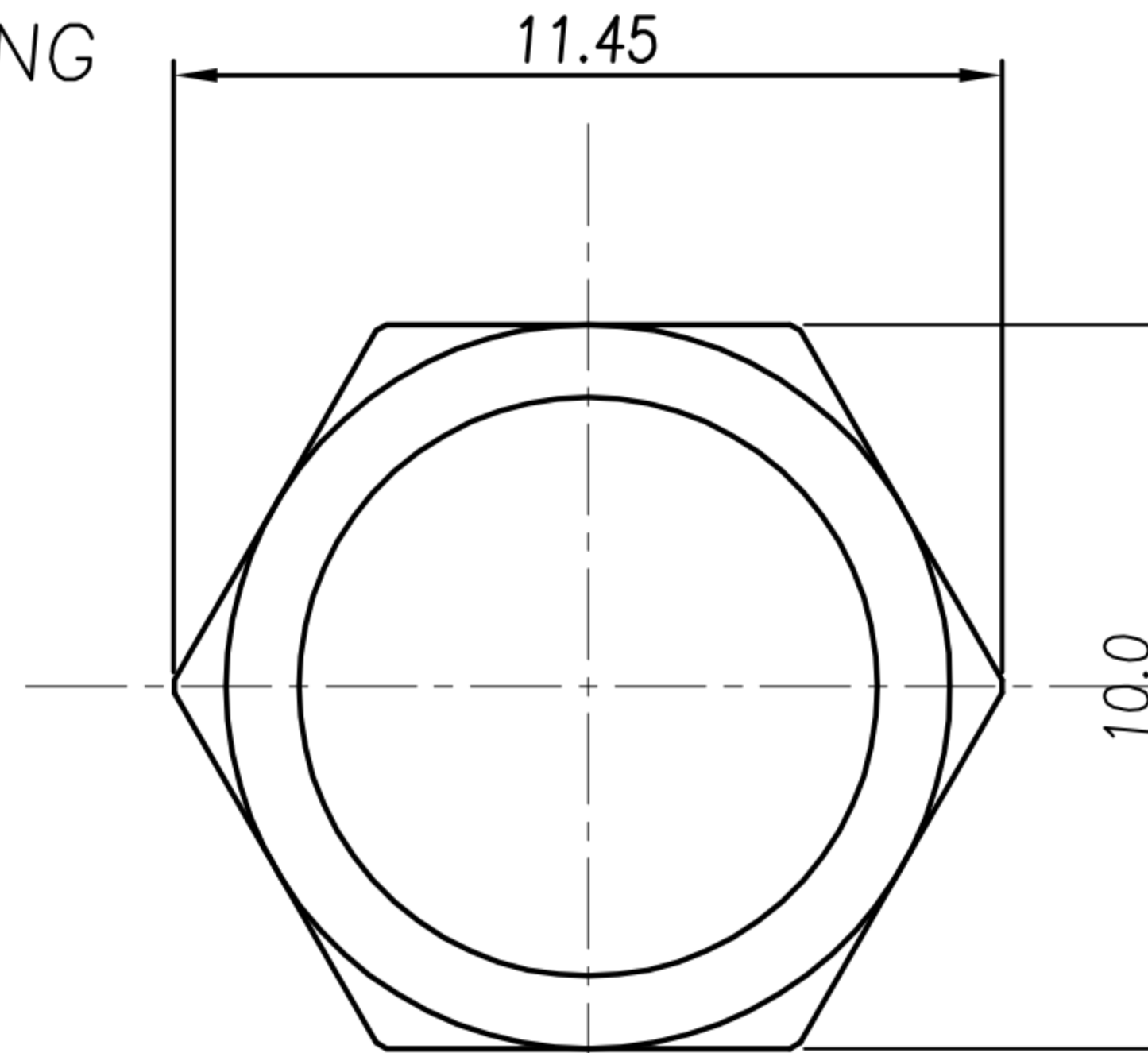

NUT

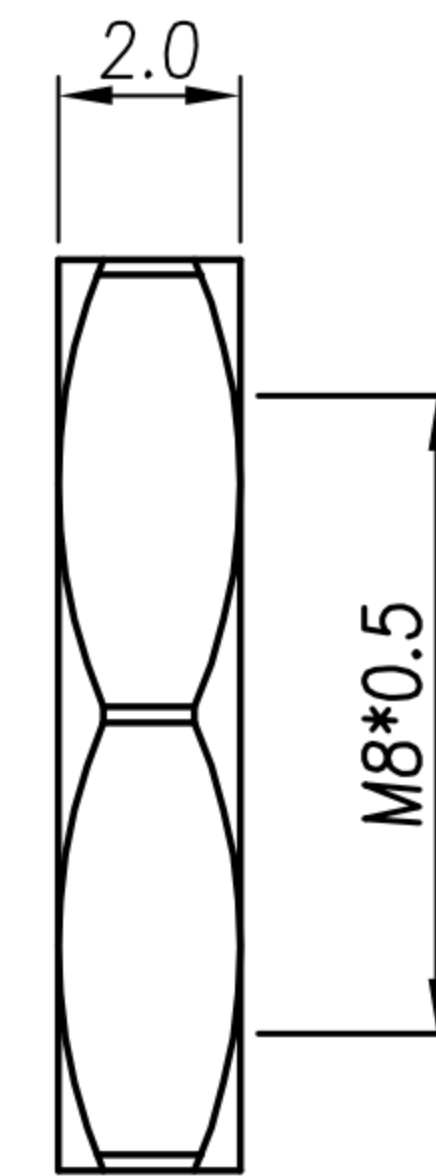

DRAWN	Jen Xie	APPEND	Emily Suen	UNIT	mm	TOLERANCE		广东科斯达电子科技有限公司 GUANG DONG KE SI DA ELECTRONIC TECHNOLOGY CO., LTD.	TITLE	防水项 M8*0.5 (M) 鍍板			SHEET	2
CHKED	Emily Suen			SCALE	1:1	.x ±0.20 .xx ±0.10 .xxx ±0.05 .xxxx ±0.03 ANGULA ±1°			PART NO.	SEE TABLE A	DWG NO.	QC5187	VERSION	A

CUSTOMER DRAWING

REV.	DESCRIPTION	APPROVED BY	DATE	ECN NO.
A	RELEASE	Fido Weng	04/03/10'	
B	CHANGE MATERIAL	Fido Weng	15/09/22'	
C				

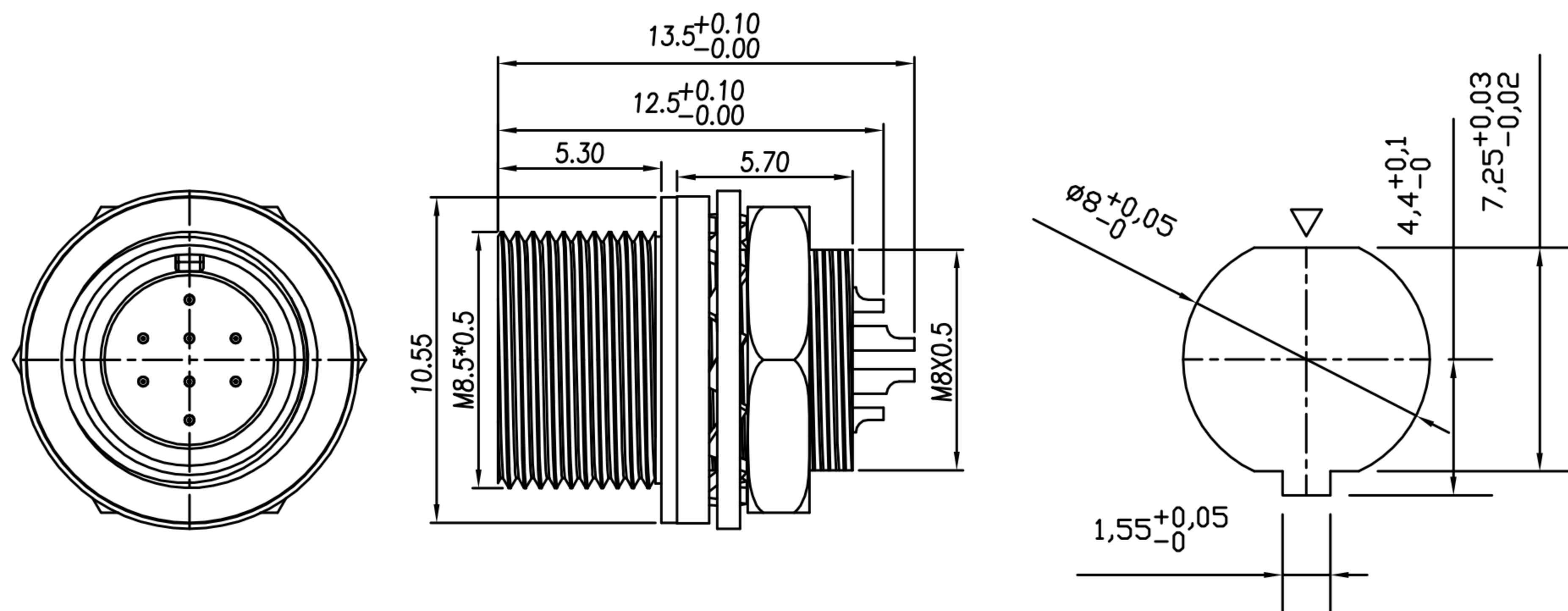

RECOMMEND PANEL CUT-OUT

- MATERIAL :
 - 1-1. HOUSING : NYLON 66 ; COLOR : BLACK
 - 1-2. CONTACT : PHOSPHOR BRONZE
 - 1-3. SHELL : Zinc Alloy
 - 1-4. NUT : BRASS
 - 1-5. O-RING : EPDM ; COLOR : BLACK
 - 1-6. WASHER : BRASS
- FINISH :
 - 2-1. CONTACT : GOLD 10u"
 - UNDER PLATE : NICKEL
 - 2-2. SHELL : NICKEL PLATED .
 - 2-3. NUT : NICKEL PLATED.
- ELECTRICAL SPECIFICATION :
 - 3-1. Rated current : 1A
 - 3-2. Rated voltage : 30V AC , 42V DC
- Environmental :
 - 4-1. Operation Temperature : -25℃~85℃

TABLE A

DI-04M2-03(4P)	DI-06M2-02(6P)	DI-08M2-05(8P)
1-1. HOUSING : NYLON 66 ; COLOR : BLACK		

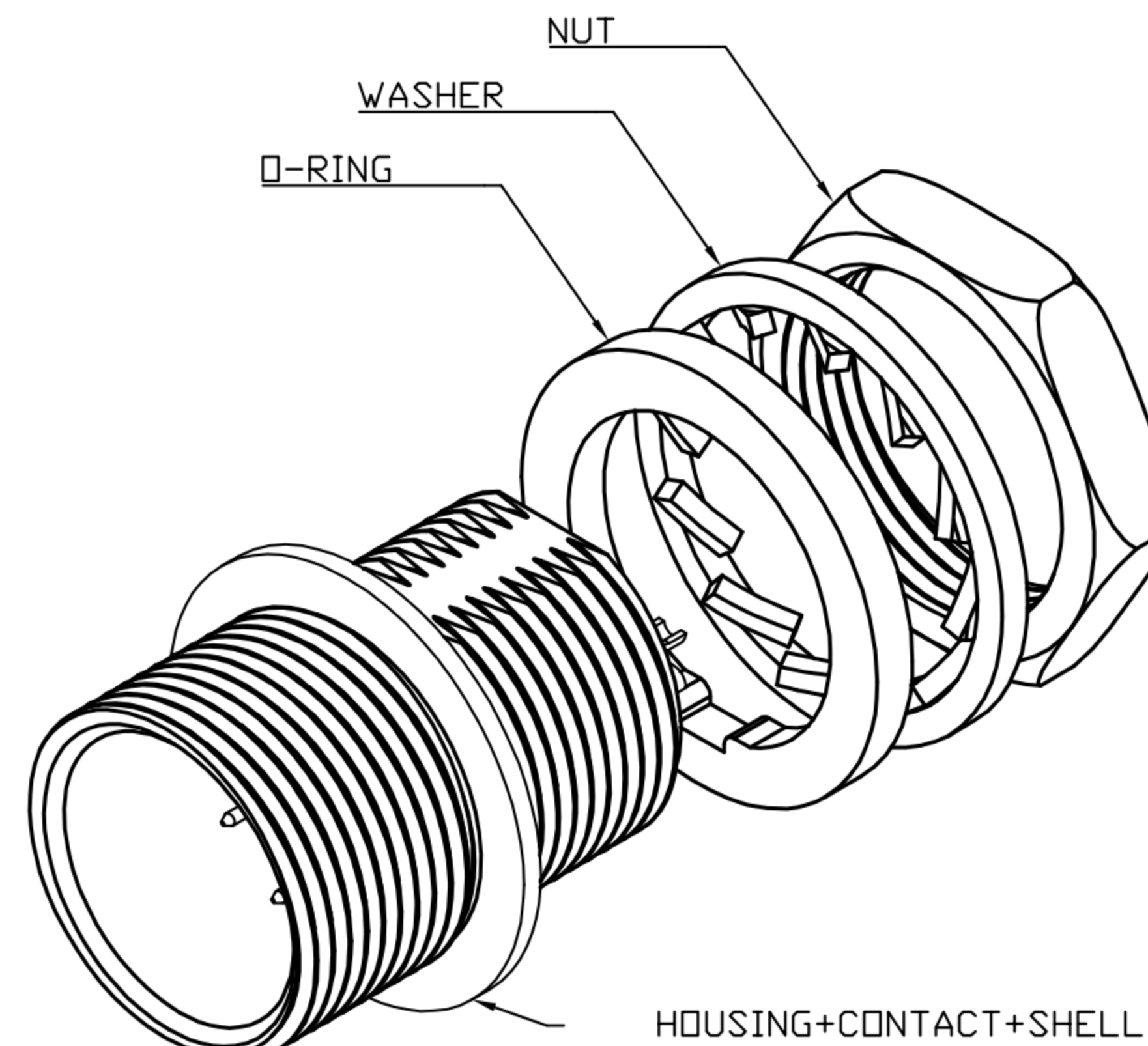

DRAWN	Jen Xie	APPEND	Emily Suen	UNIT	mm	TOLERANCE	广东科斯达电子科技有限公司 GUANG DONG KE SI DA ELECTRONIC TECHNOLOGY CO., LTD.	TITLE	防水頭 M8*0.5 (M) 鑄板			SHEET	1/2
CHKD	Emily Suen			SCALE	1:1	.x ±0.20 .xx ±0.10 .xxx ±0.05 .xxxx ±0.03 ANGULA ±1°		PART NO.	SEE TABLE A	DWG NO.	QC5187	VERSION	B