

REV.	DESCRIPTION	APPROVED BY	DATE	ECN NO.
A	RELEASE	Fido Weng	17/01/13'	
B				
C				

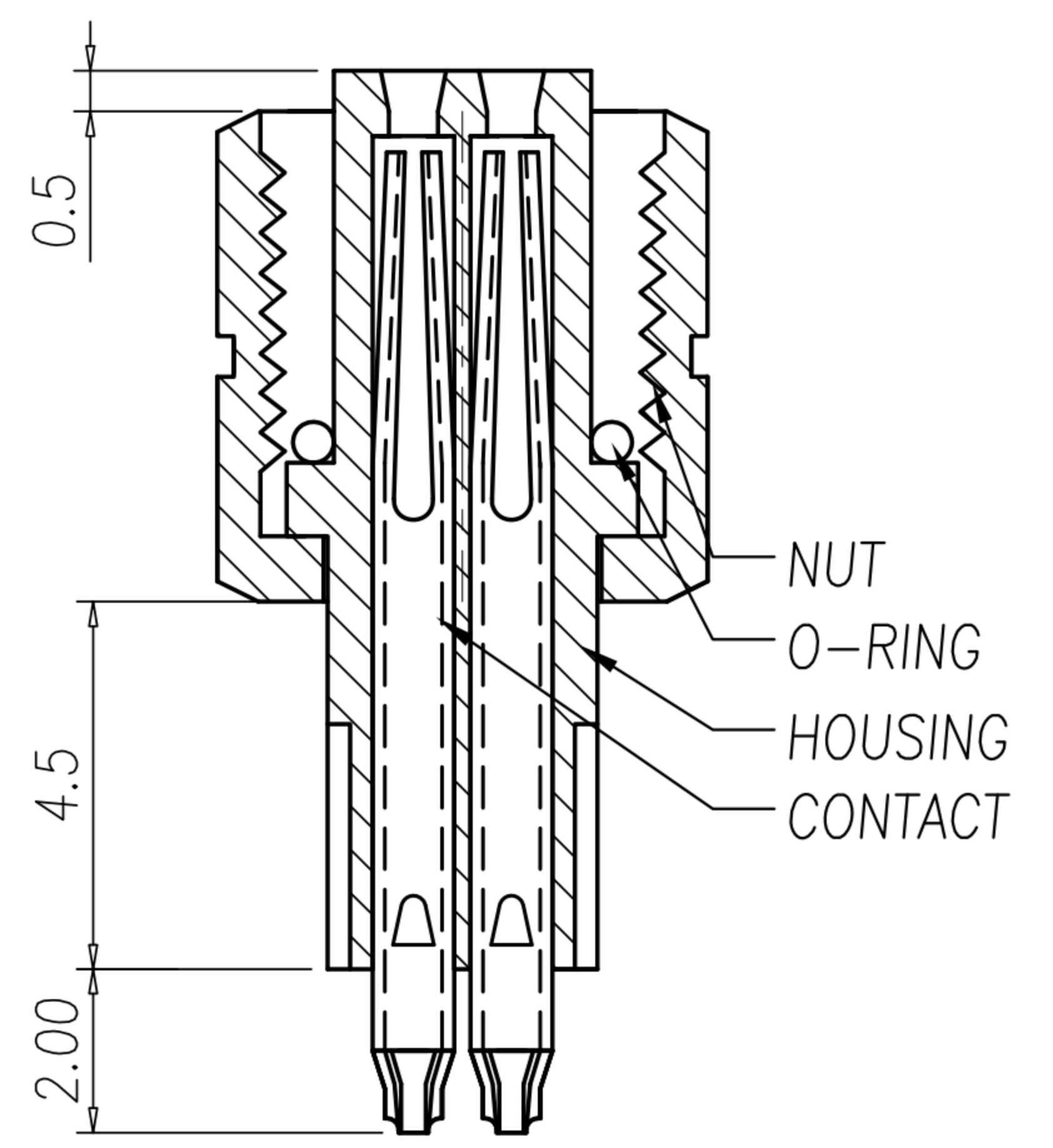

NUT

TABLE A

4P	3P	2P

WP-04F2-166-11	BLACK Cr	GOLD 10u"
WP-04F2-165-11	BLACK NICKEL	GOLD 10u"
WP-04F2-143-11	Satin Nickel	GOLD 10u"
WP-03F2-64-11	Satin Nickel	GOLD 10u"
WP-02F2-40-11	Satin Nickel	GOLD 10u"
WP-02F2-21	Satin Nickel	GOLD FLASH
WP-03F2-34	Satin Nickel	GOLD FLASH
WP-04F2-82	BLACK NICKEL	GOLD FLASH
WP-04F2-88	BLACK Cr	GOLD FLASH
WP-04F2-49	Satin Nickel	GOLD FLASH
PART NO.	NUT PLATED	CONTACT FINISH

- MATERIAL :
 - 1-1. HOUSING : TPU ; COLOR : BLACK
 - 1-2. CONTACT : PHOSPHOR BRONZE
 - 1-3. NUT : BRASS
 - 1-4. O-RING : NBR ; COLOR : BLACK
- FINISH :
 - 2-1. CONTACT : SEE TABLE A
 - 2-2. NUT : SEE TABLE A
- ELECTRICAL SPECIFICATION :
 - 3-1. Rated current : 1A
 - 3-2. Rated Voltage : 60V
 - 3-3. Water proof: IP67
- Environmental :
 - 4-1. Operation Temperature : -20 °C~85°C