

CUSTOMER DRAWING

REV.	DESCRIPTION	APPROVED BY	DATE	ECN NO.
△A	RELEASE	Emily Suen	22/11/11'	
△B	CHANGE MATERIAL	Emily Suen	19/09/22'	
△C				
△D				

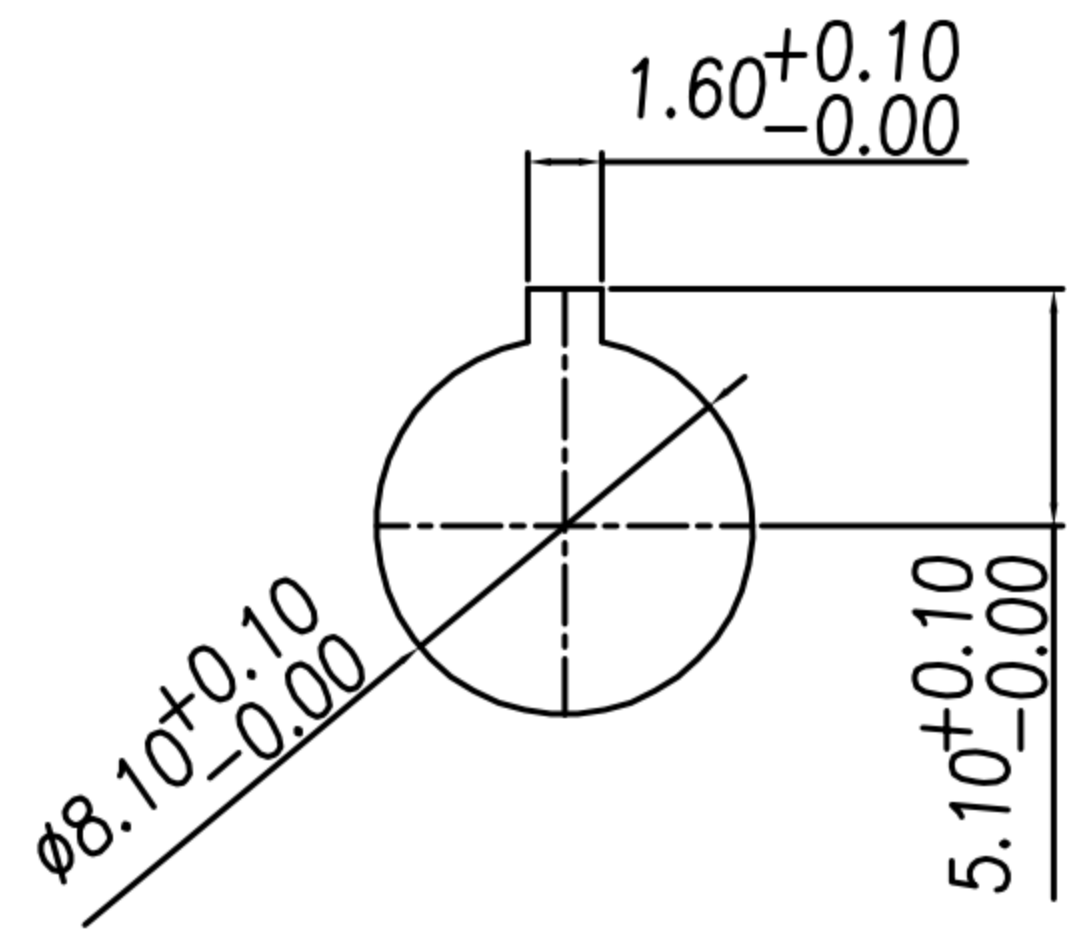

RECOMMENDED MOUNTING HOLE  
(Panel thickness 0.7~2)

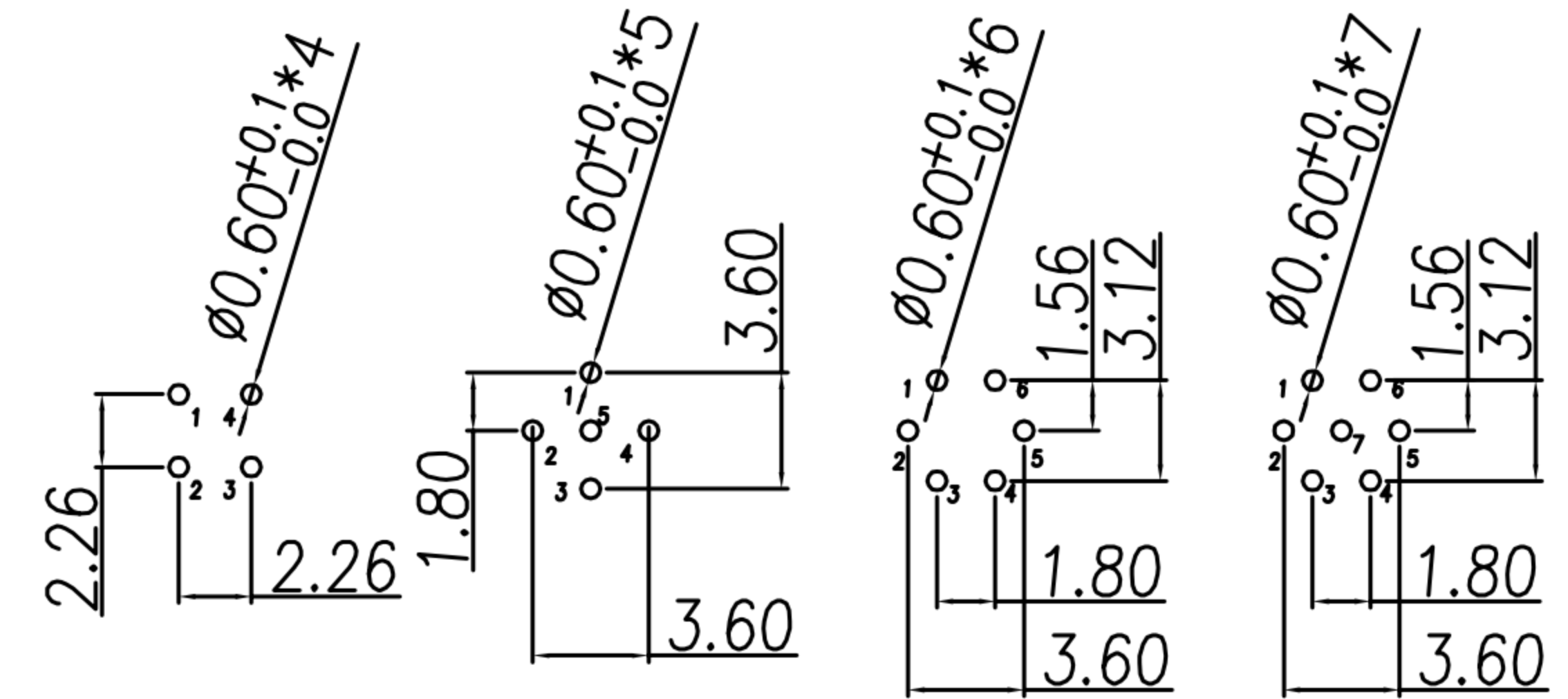
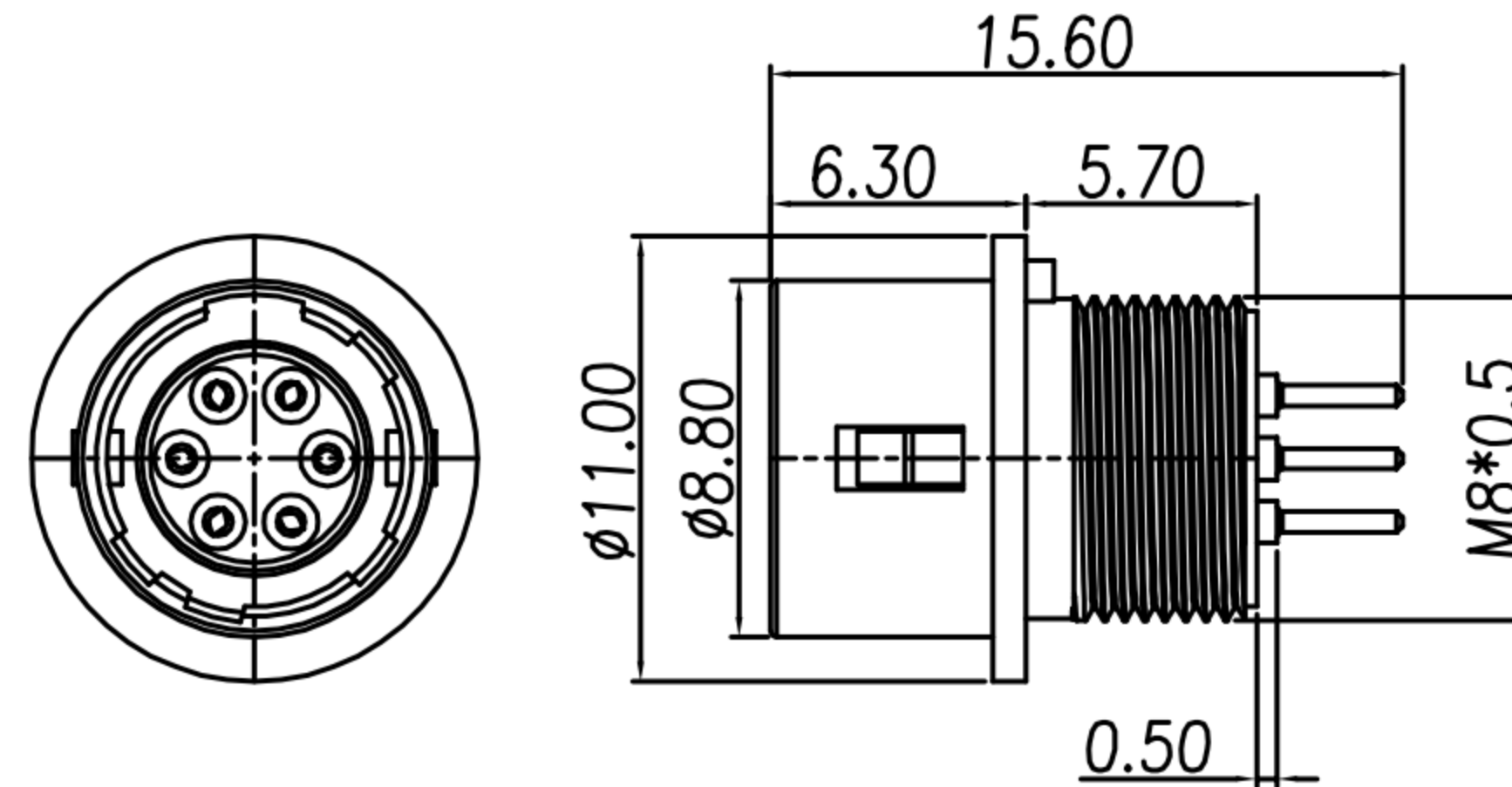

RECOMMEND P.C.B LAYOUT

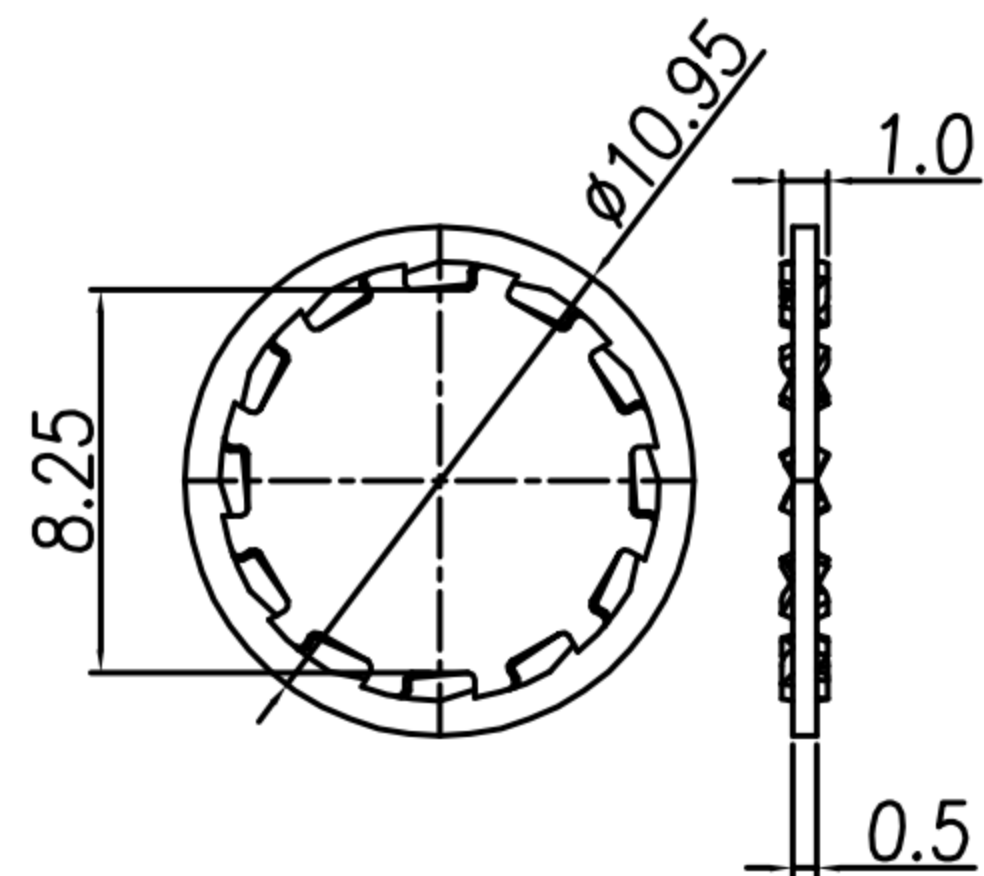

WASHER

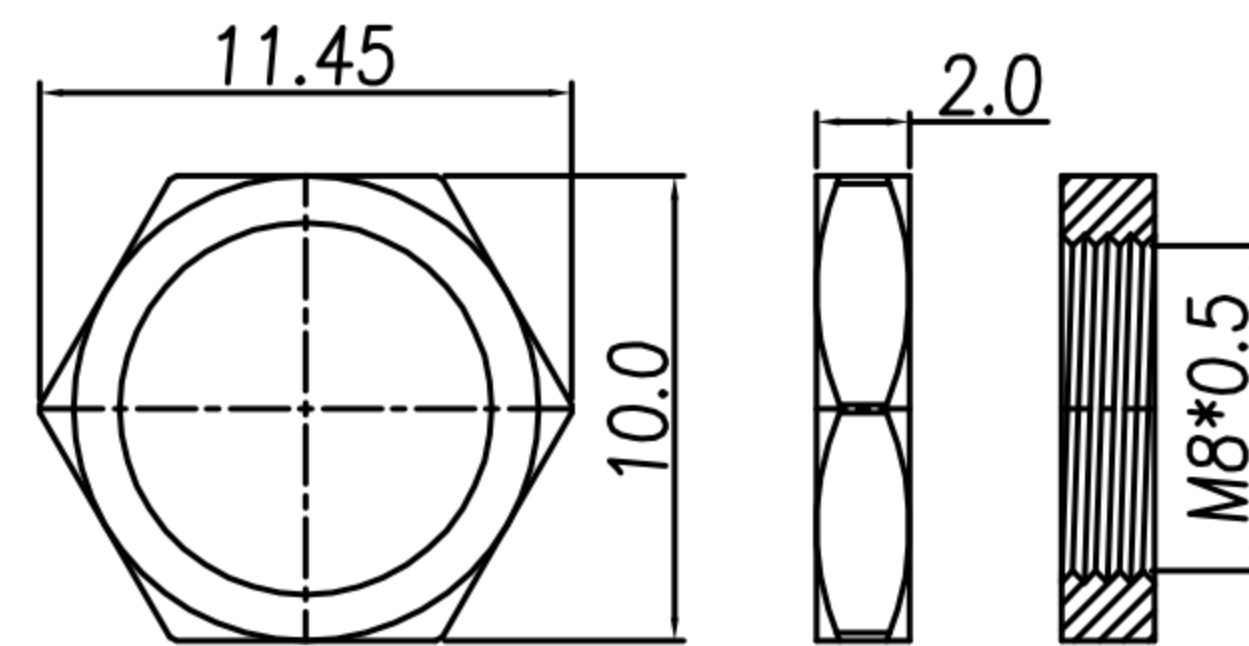

NUT

TABLE A

CONTACT ARRANGEMENT(FRONT VIEW)			
DI-04F3-02	DI-05F3-01	DI-06F3-02	DI-07F3-01

1. MATERIAL :
- △ 1-1. HOUSING : NYLON66 UL94V-0; COLOR : BLACK
  - 1-2. CONTACT : BRASS
  - 1-3. SHELL : ZINC ALLOY
  - 1-4. SPRING : STAINLESS STEEL
  - 1-5. WASHER : PHOSPHOR BRONZE
  - 1-6. NUT : BRASS

2. FINISH :
- 2-1. CONTACT : GOLD FLASH
  - 2-2. SHELL : NICKEL
  - 2-3. WASHER : NICKEL
  - 2-4. NUT : NICKEL

3. ELECTRICAL SPECIFICATION :
- 3-1. Rated current : 2A
  - 3-2. Rated voltage : 4PIN 150V AC / 200V DC ;  
5~7PIN 100V AC / 140V DC
4. Environmental :
- 4-1. Operation Temperature : -25℃~85℃

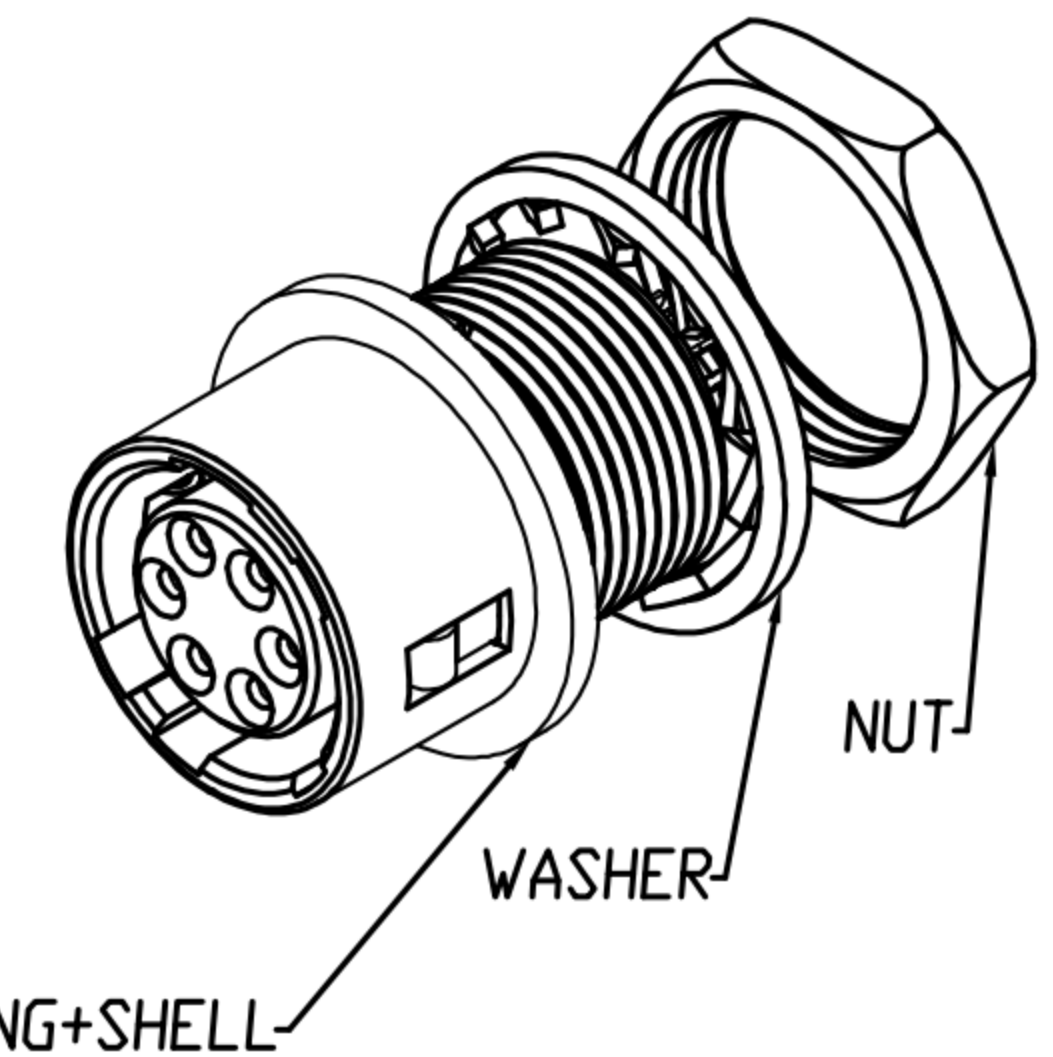

DRAWN	Ku Chou	APPV'L	Emily Suen	UNIT	mm	TOLERANCE		广东科斯达电子科技有限公司 GUANG DONG KE SI DA ELECTRONIC TECHNOLOGY CO., LTD.	TITLE	DIN (F) RECEPTACLE 鍍金/鍍銀式(SHELL SIZE 7mm)			SHEET	1
CHK'D	Emily Suen			SCALE	1:1	.x ±0.20 .xx ±0.10 .xxx ±0.05 .xxxx ±0.03 ANGULA ±1°			PART NO.	SEE TABLE A	DWG NO.	QC5669	VERSION	B