

CUSTOMER DRAWING

REV.	DESCRIPTION	APPROVED BY	DATE	ECN NO.
A	RELEASE	Fido Weng	22/03/10'	
B	ADD TABLE A	Fido Weng	24/10/13'	
C				

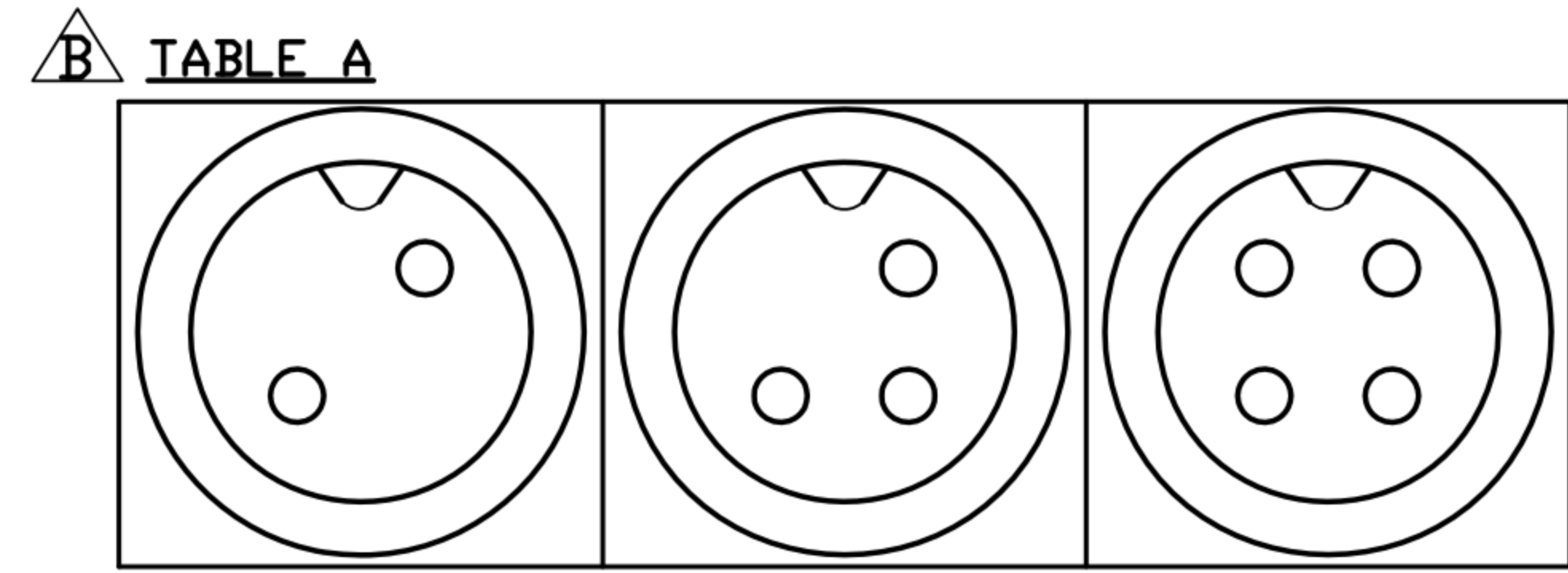

- MATERIAL :
 - 1-1. HOUSING : PBT UL94V-0 ; COLOR : BLACK
 - 1-2. CONTACT : BRASS
 - 1-3. NUT : BRASS
 - 1-4. SHELL : BRASS
 - 1-5. O-RING : NBR ; COLOR : BLACK
- FINISH :
 - 2-1. CONTACT : SEE TABLE A
 - 2-2. NUT : NICKEL PLATED.
 - 2-3. SHELL : NICKEL PLATED.
- ELECTRICAL SPECIFICATION :
 - 3-1. Rated current : 1A
 - 3-2. Rated voltage : 60V
 - 3-3. Water proof : IP67
- Environmental :
 - 4-1. Operation Temperature : -20℃~85℃

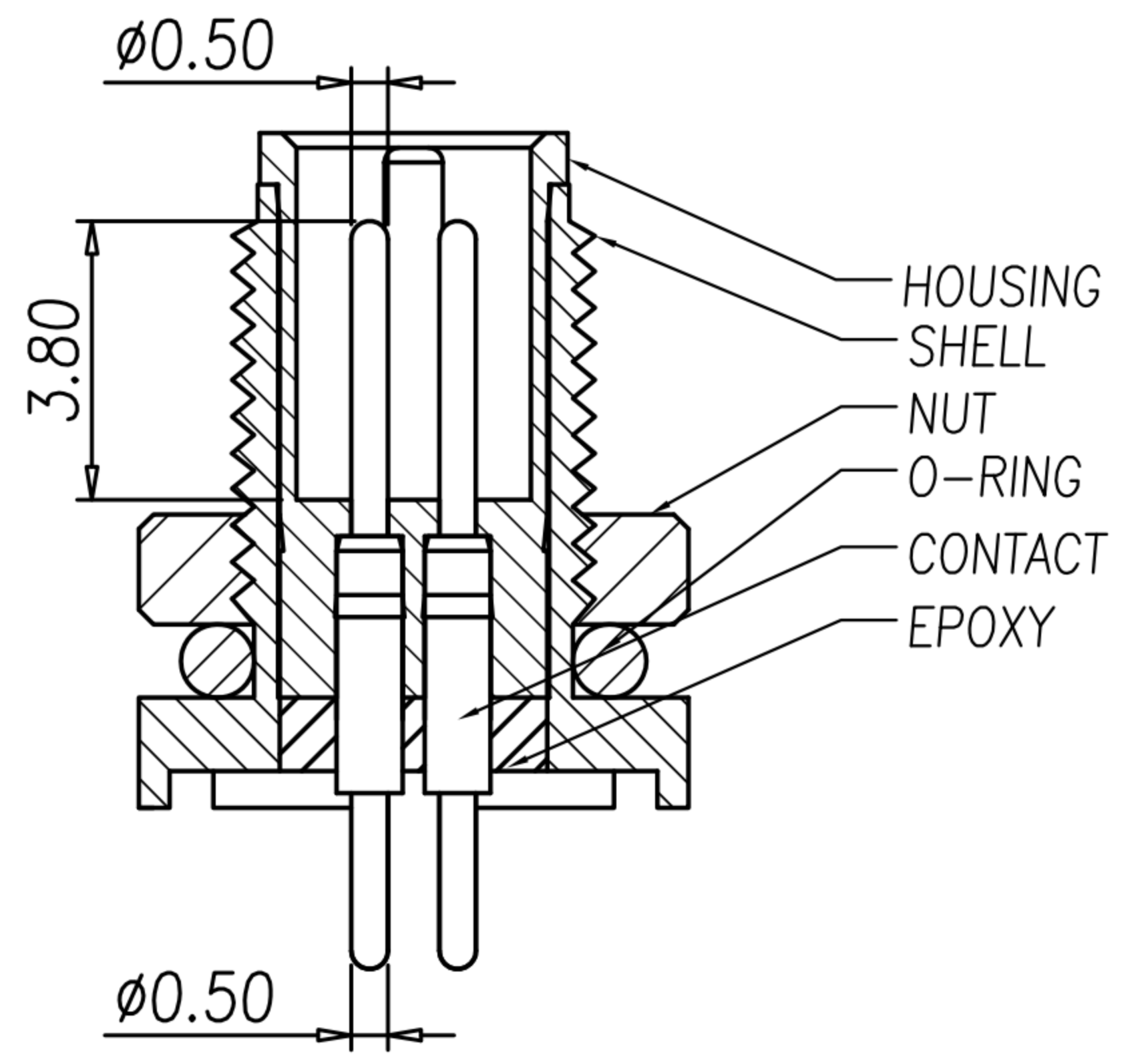
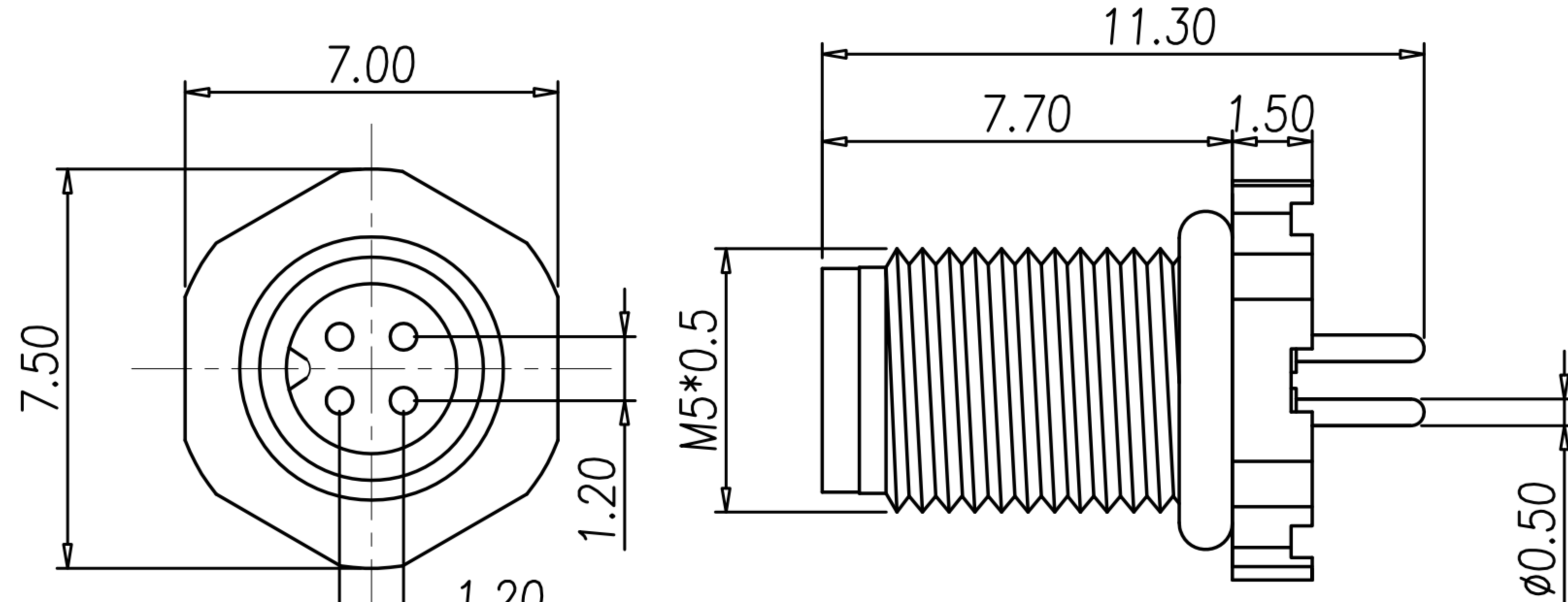
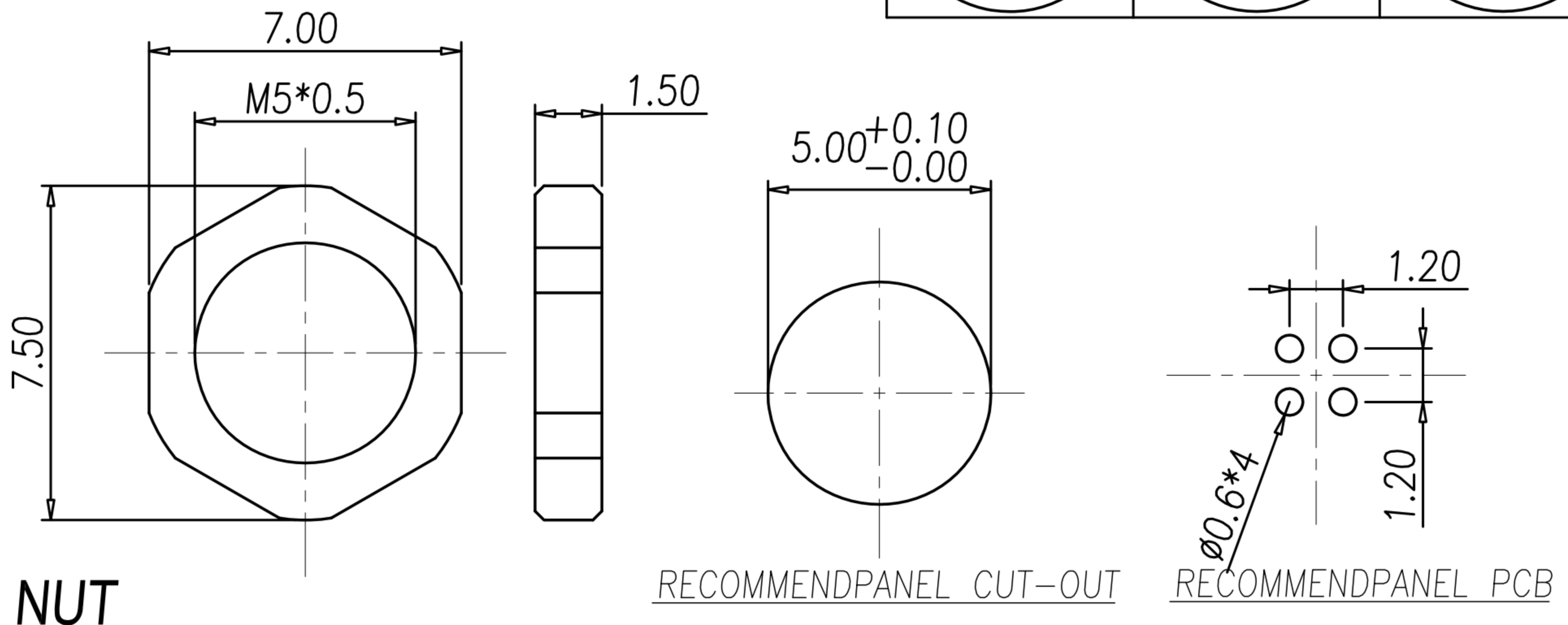

TABLE A

WP-04M2-117-11	GOLD 10u"
WP-03M2-60-11	GOLD 10u"
WP-02M2-41-11	GOLD 10u"
WP-04M2-41	GOLD FLASH
WP-03M2-36-11	GOLD FLASH
WP-02M2-26-11	GOLD FLASH
PART NO	FINISH

DRAWN	Ku Chou	APP'D	Fido Weng	UNIT	mm	TOLERANCE			TITLE	M5*0.5 (M) 板端			SHEET	
CHK'D	Emily Suen			SCALE	1:1	.x ±0.20 .xx ±0.10 .xxx ±0.05 .xxxx ±0.03 ANGULA ±1°			PART NO.	SEE TABLE A	DWG NO.	QC4675	VERSION	