

CUSTOMER DRAWING

REV.	DESCRIPTION	APPROVED BY	DATE	ECN NO.
C	CHANG DIM & RELEASE	Fido Weng	02/06/09'	ECN09087
D	CHANG SHELL FINISH	Fido Weng	14/08/09'	ECN09125
E	CHANG DIM	Yeh Chou	29/11/12'	ECN12032
F	MODIFY DRAWING	Fido Weng	17/12/13'	

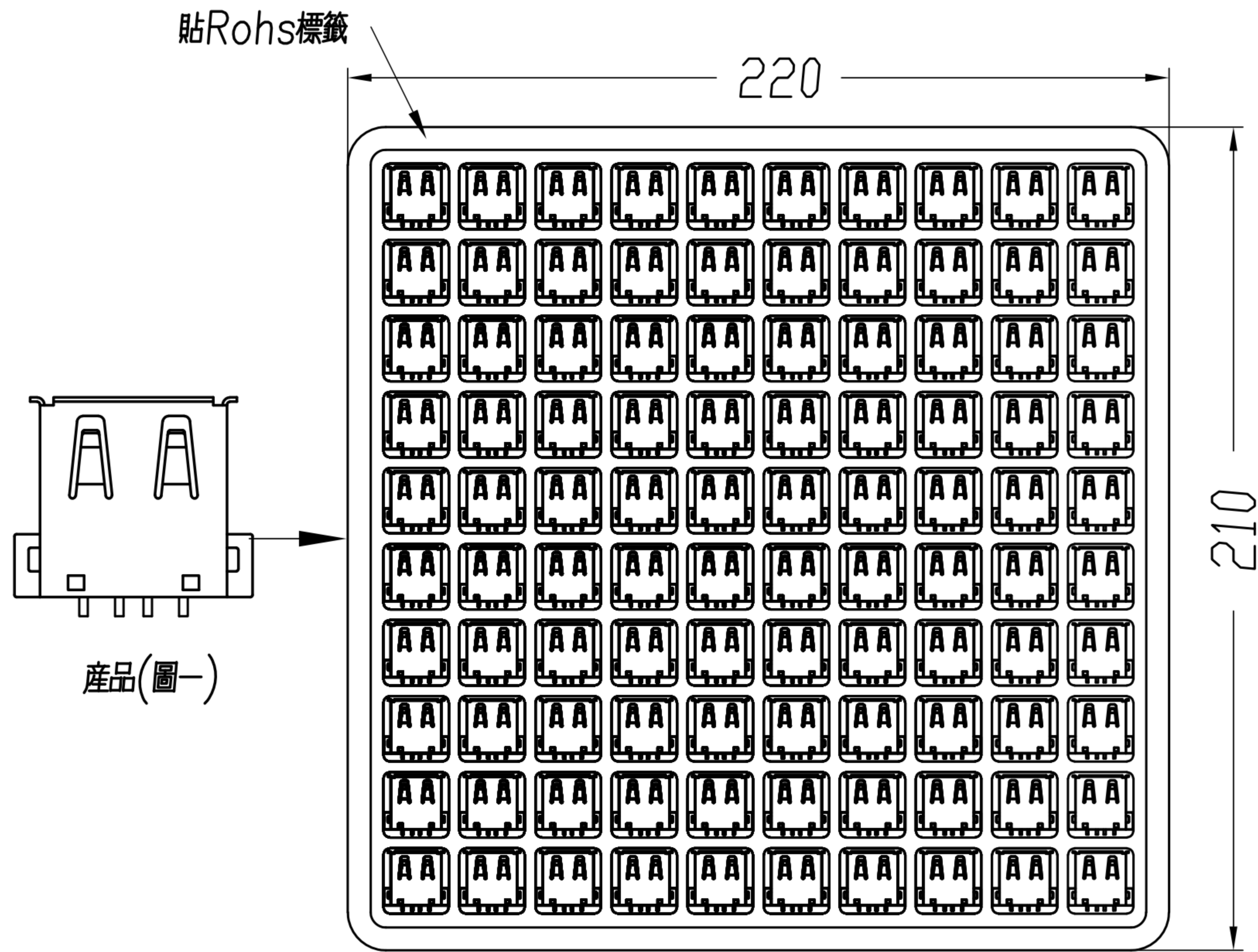

TRAY盤(圖二)

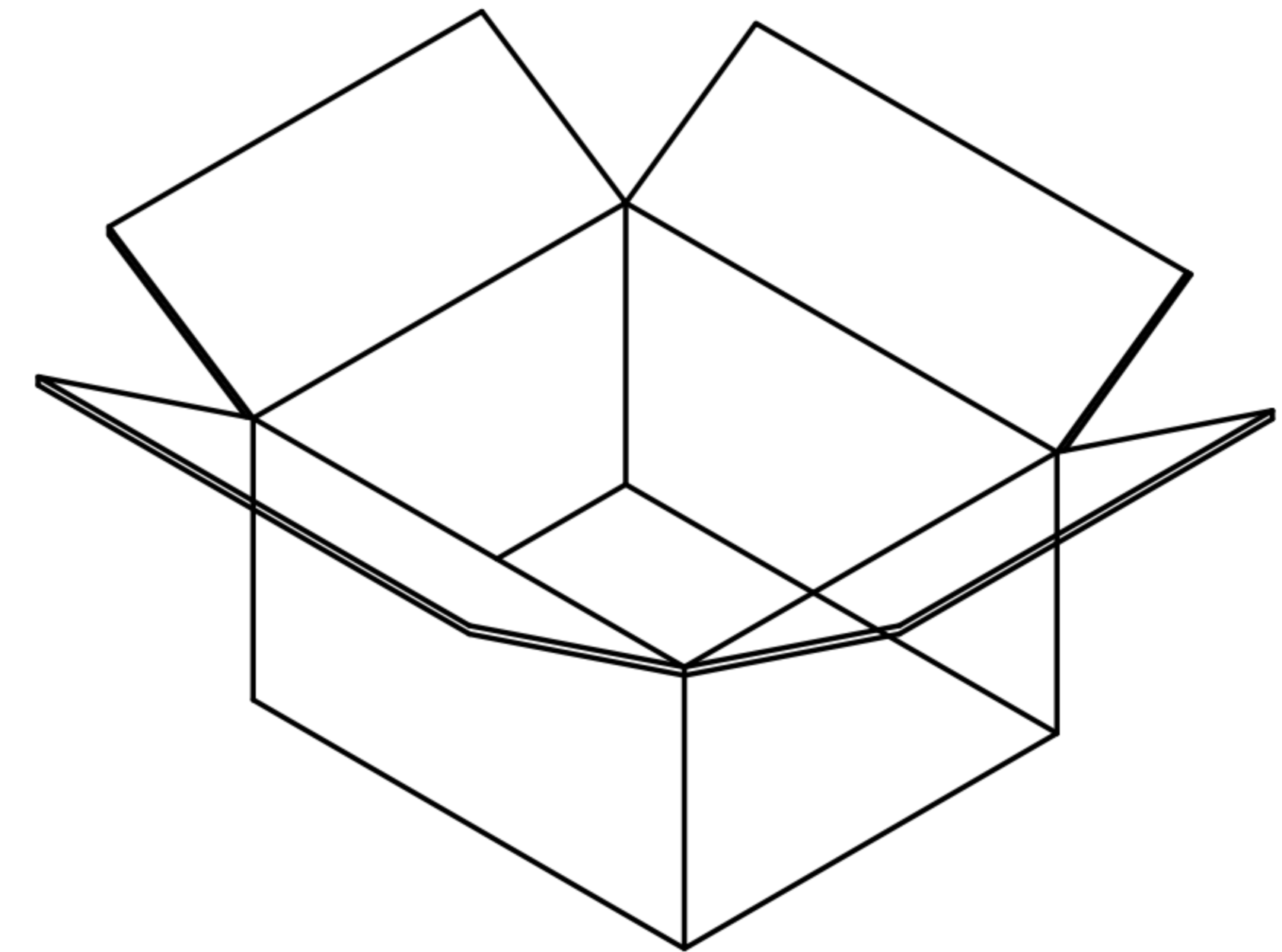

未封之紙箱(圖三)

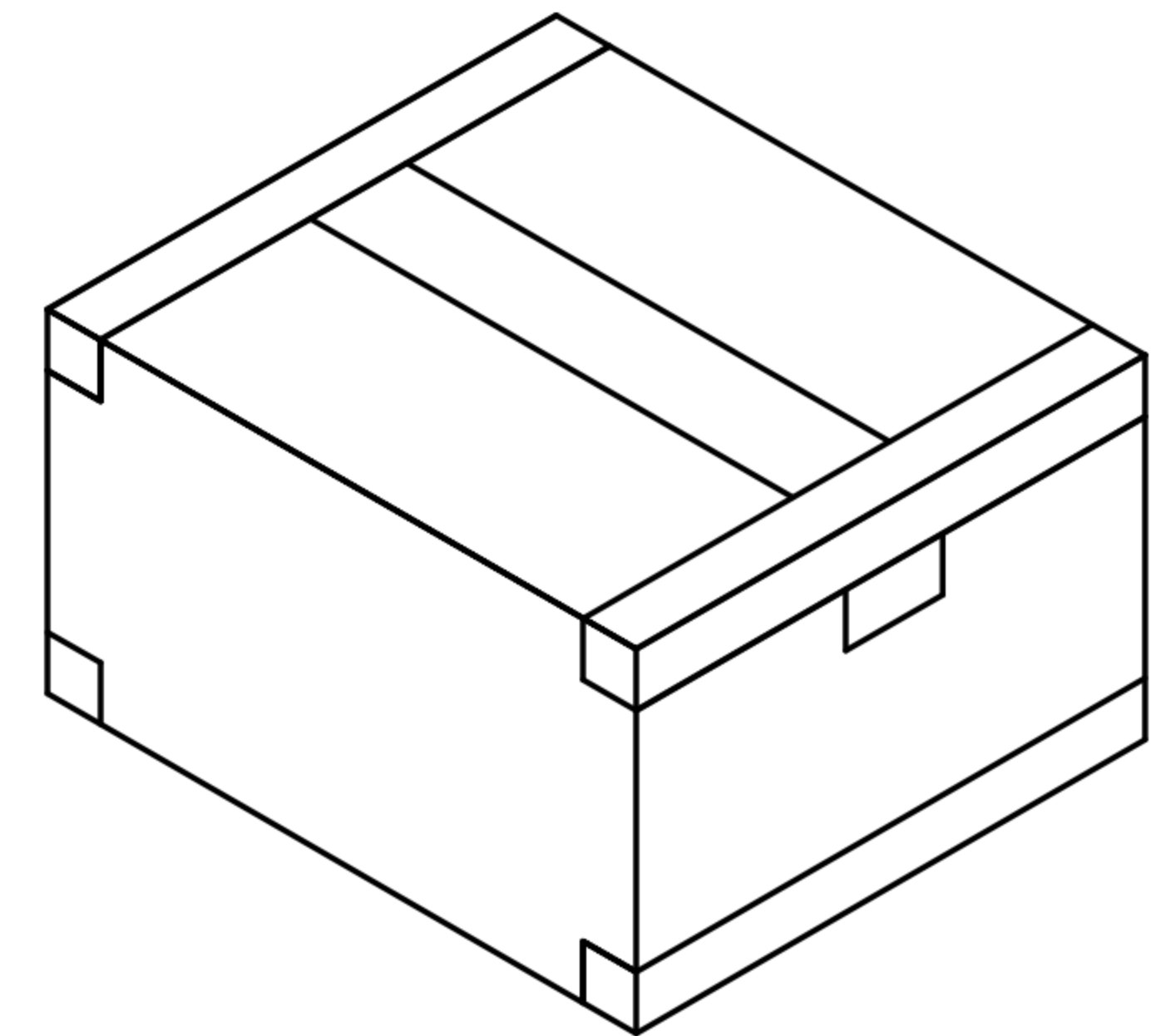

封好外紙箱(圖四)

包裝說明:

1. 如圖(一、二)所示將ok的產品端子朝上放入TRAY盤內
2. 每盤裝100PCS, 不可短少, 成品在真空盤內不可活動, 蓋上真空盤蓋, 四周需訂好。
3. 在紙箱四個角上分別放置護腳板, 在將訂好的真空盤放入箱內, 共裝30盤, 有3K產品, 最後用透明膠帶密封紙箱, 如圖(三、四)所示。
4. 紙箱外貼上環保標籤, 合格標籤, 產品規格說明的右上方

DRAWN	Mark Kao	APP'D	Ku Chou	UNIT	mm	TOLERANCE			TITLE	USB A(F)SMT TYPE			SHEET	2
CHK'D	Emily Suen			SCALE	1:1				PART NO.	US-04F4-04	DWG NO.	QC1473	VERSION	F

广东科斯达电子科技有限公司  
GUANG DONG KE SI DA ELECTRONIC TECHNOLOGY CO., LTD.



# CUSTOMER DRAWING

REV.	DESCRIPTION	APPROVED BY	DATE	ECN NO.
△C	CHANG DIM & RELEASE	Fido Weng	02/06/09'	ECN09087
△D	CHANG SHELL FINISH	Fido Weng	14/08/09'	ECN09125
△E	CHANG DIM	Yeh Chou	29/11/12'	ECN12032
△F	MODIFY DRAWING	Fido Weng	17/12/13'	

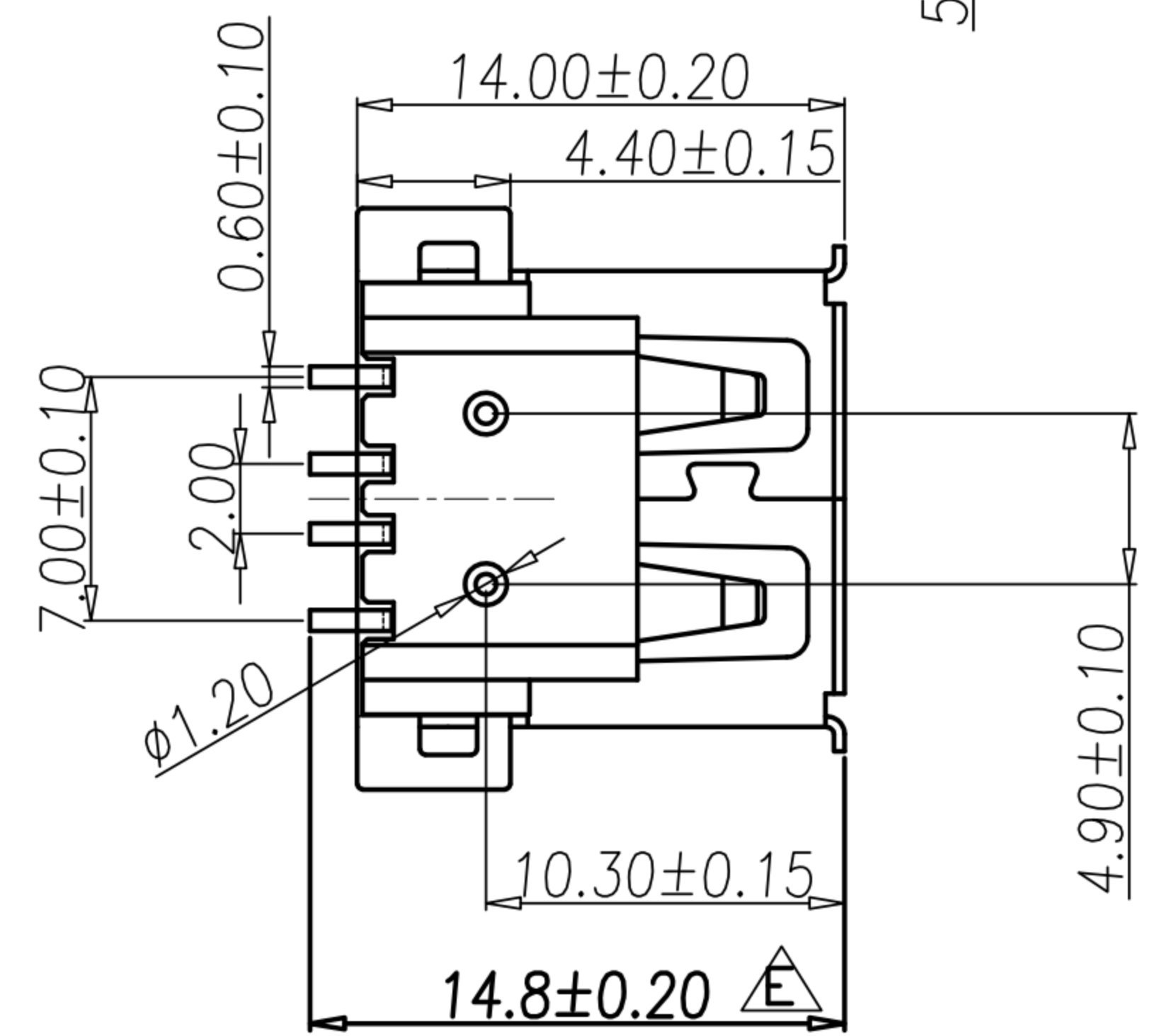
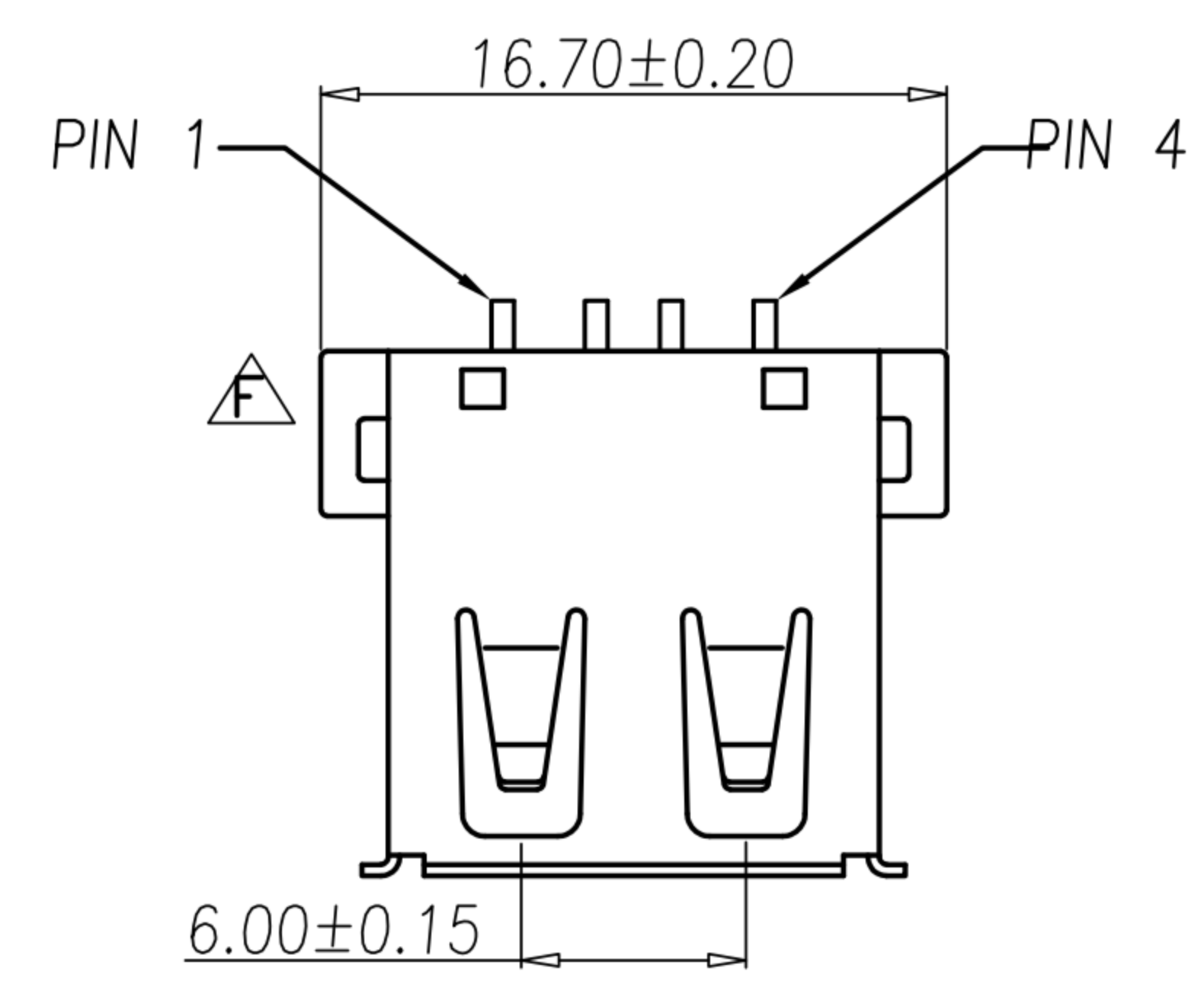
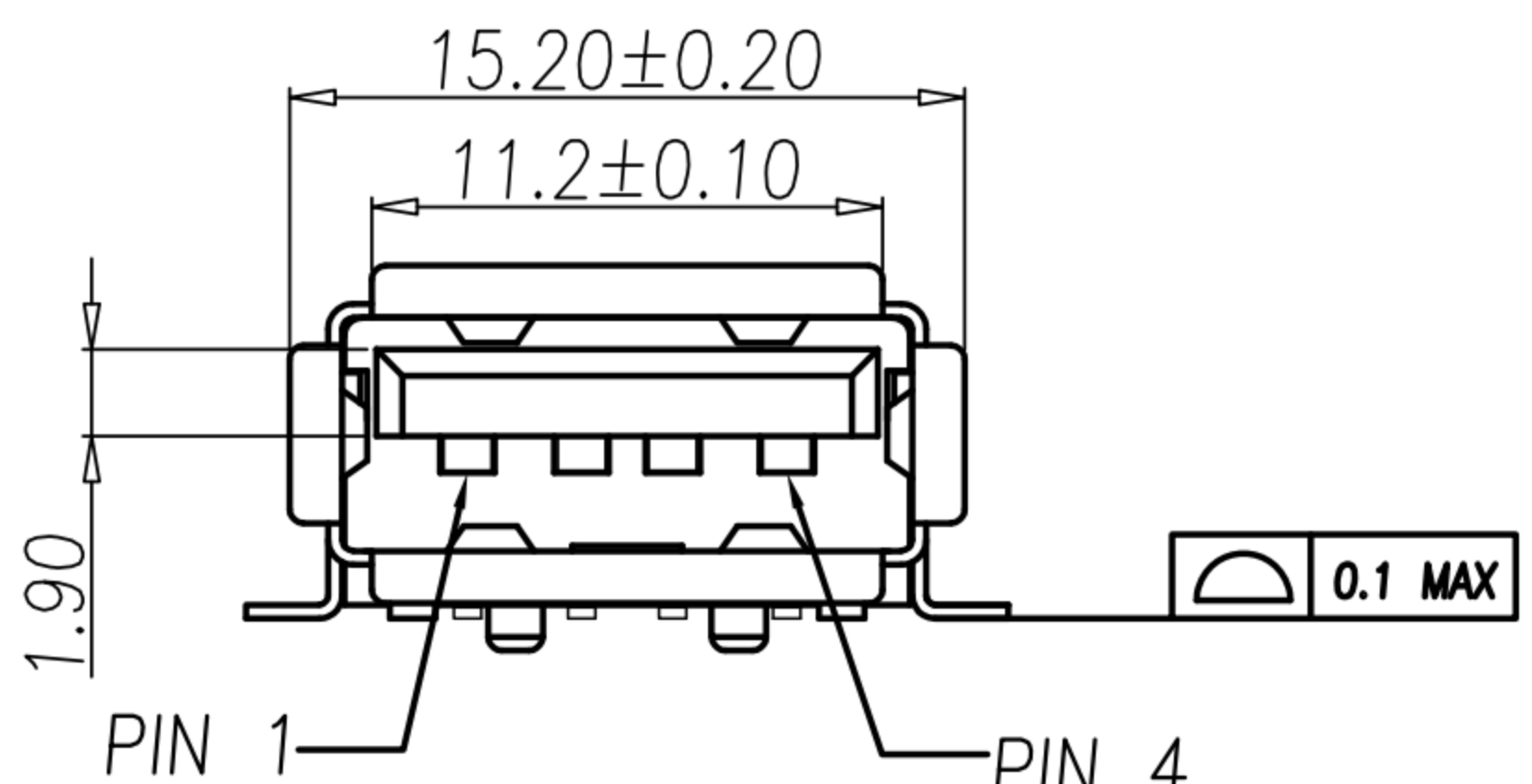
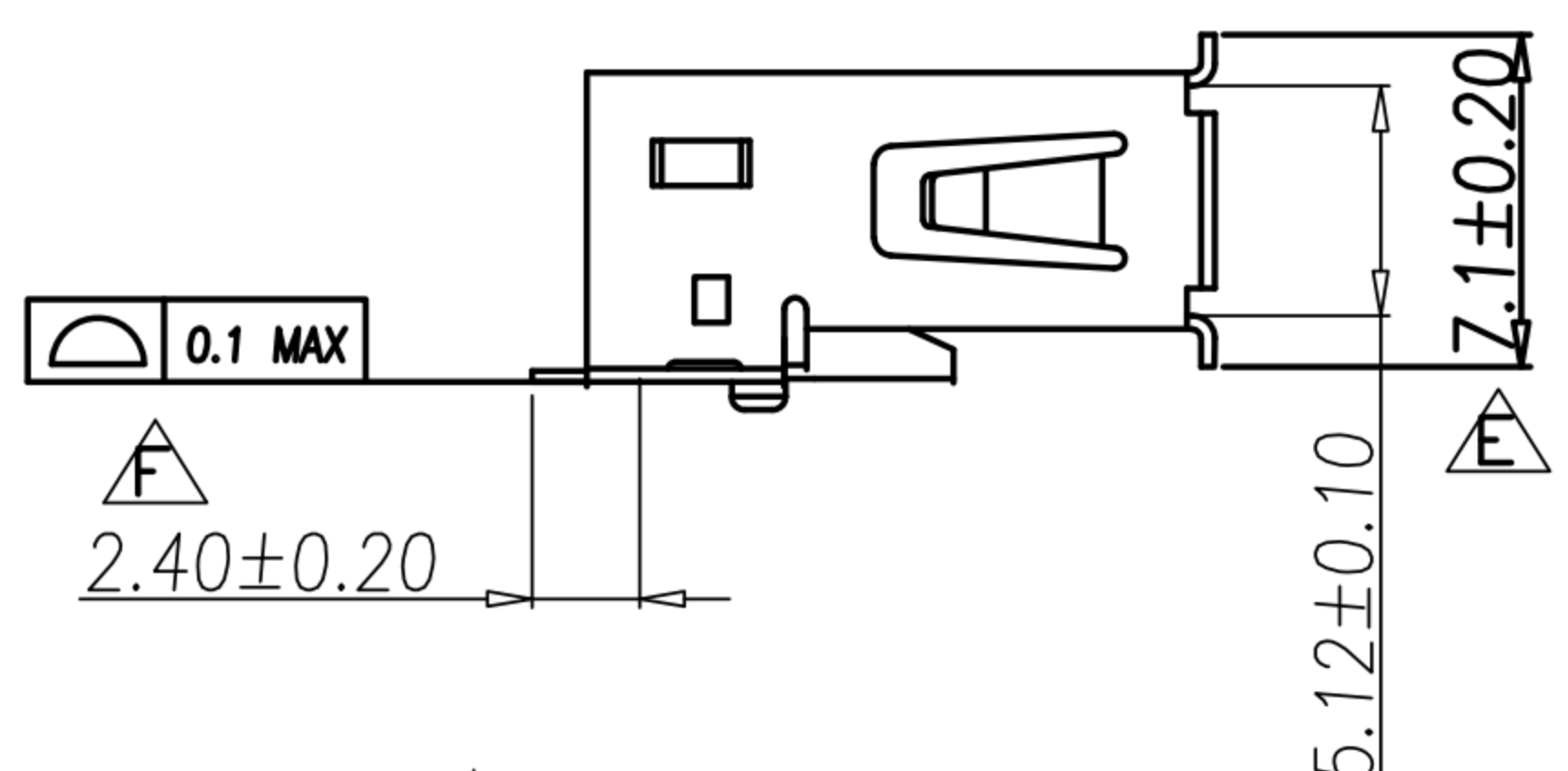

- Note:
- Material:
    - Insulator: LCP UL94V-0 COLOR: WHITE
    - Contact: PHOSPHER BRONZE
    - Shell: K7, t=0.30mm.
  - Specification:
    - Rated voltage and current: 1.5A at 250V AC minimum.
    - Dielectric withstanding voltage: 500V AC/1 minute without breakdown.
    - Contact resistance: Before life test 30m ohm max, After life tset 50m ohm max.
    - Insulation resistance: 1000M ohm min.
    - Insertion force: 35 Newtons maximum.
    - Extraction force: 10 Newtons minimum.
    - Solderability: Terminal shall be immersed in flux before text, Then dip in molten solder for 5±0.5 sec. At 245±5°C.
  - Finishes:
    - Contacts: Underplate: Nickel 30~80u" MIN. Contact Area: Gold FLASH MIN. Solder Tails Area: Matte Tin 30~80u" MIN.
    - Shell: 150u"-200u" Nickel underplating over all D
  - ORDERING CODE: US-04F4-04

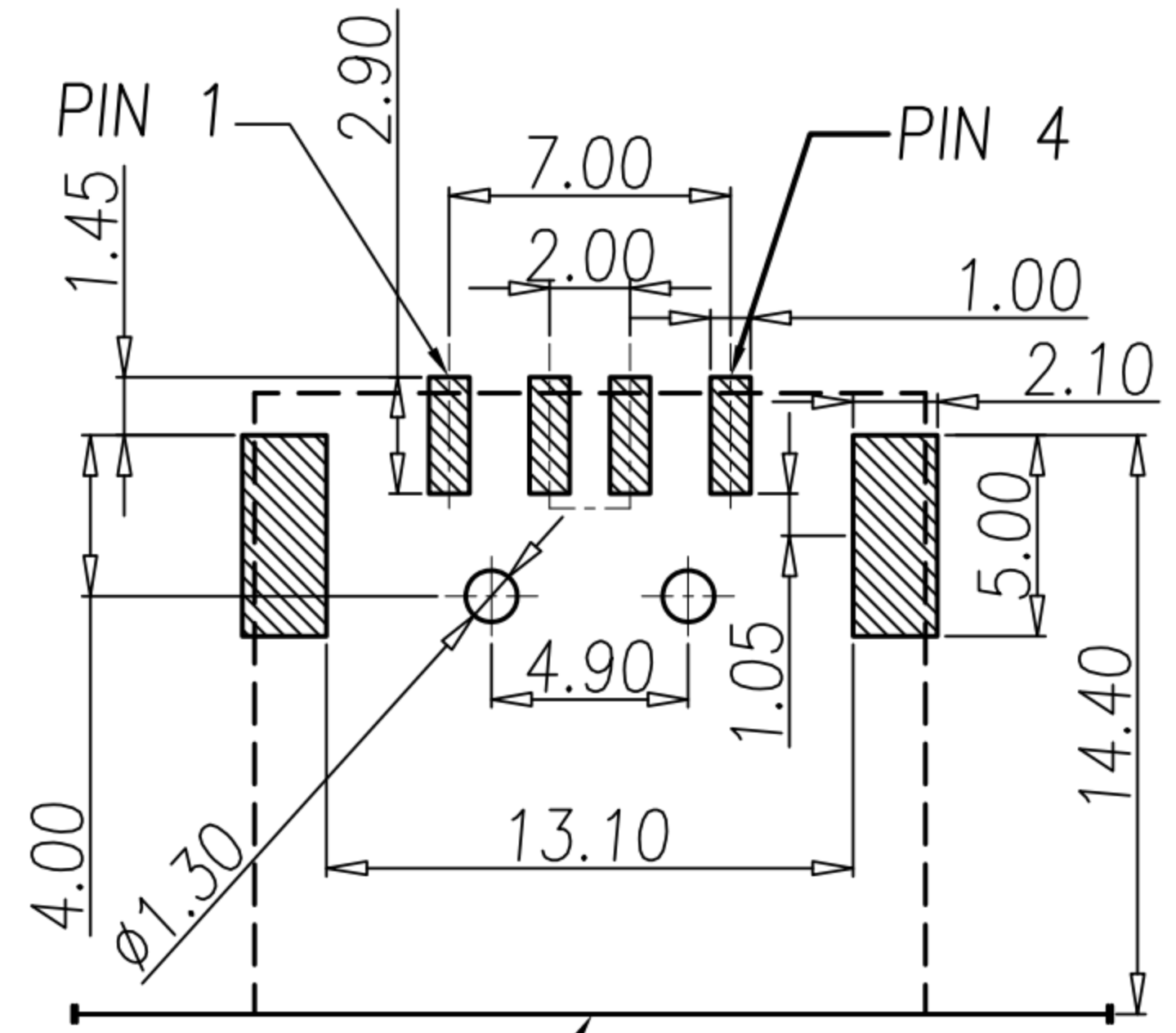

P.C.B. COMPONENT SIZE LAYOUT (TOP VIEW) TOLERANCE ±0.05 mm

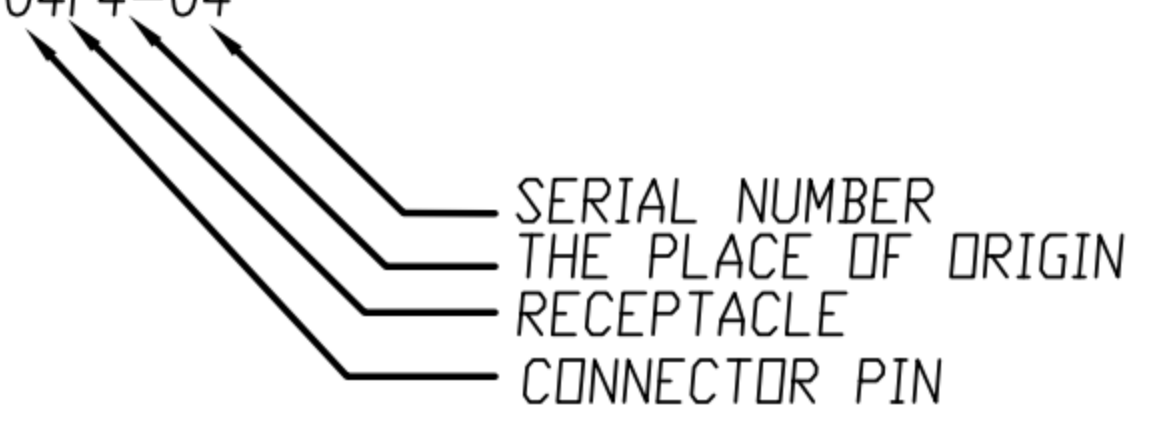

DRAWN	Mark Kao	APP'D	Ku Chou	UNIT	mm	TOLERANCE		广东科斯达电子科技有限公司 GUANG DONG KE SI DA ELECTRONIC TECHNOLOGY CO., LTD.	TITLE	USB A(F)SMT TYPE			SHEET
CHK'D	Emily Suen			SCALE	1:1	.x ±0.20 .xx ±0.10 .xxx ±0.05 .xxxx ±0.03 ANGULA ±1°			PART NO.	US-04F4-04	DWG NO.	QC1473	VERSION