

CUSTOMER DRAWING

REV.	DESCRIPTION	APPROVED BY	DATE	ECN NO.
A	RELEASE	Emily Suen	01/08/11'	
B				
C				
D				

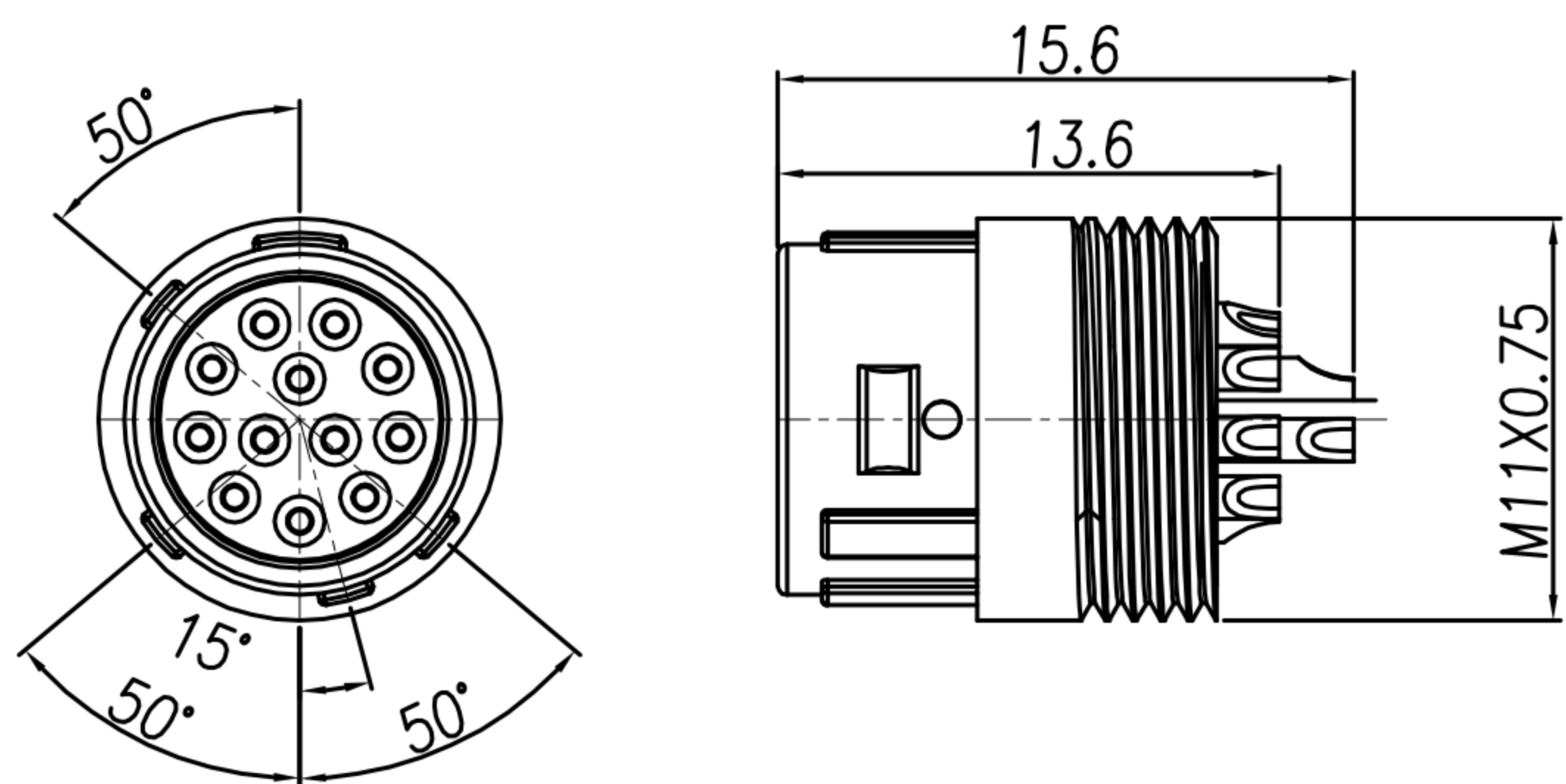

HOUSING + CONTACT + SHELL A

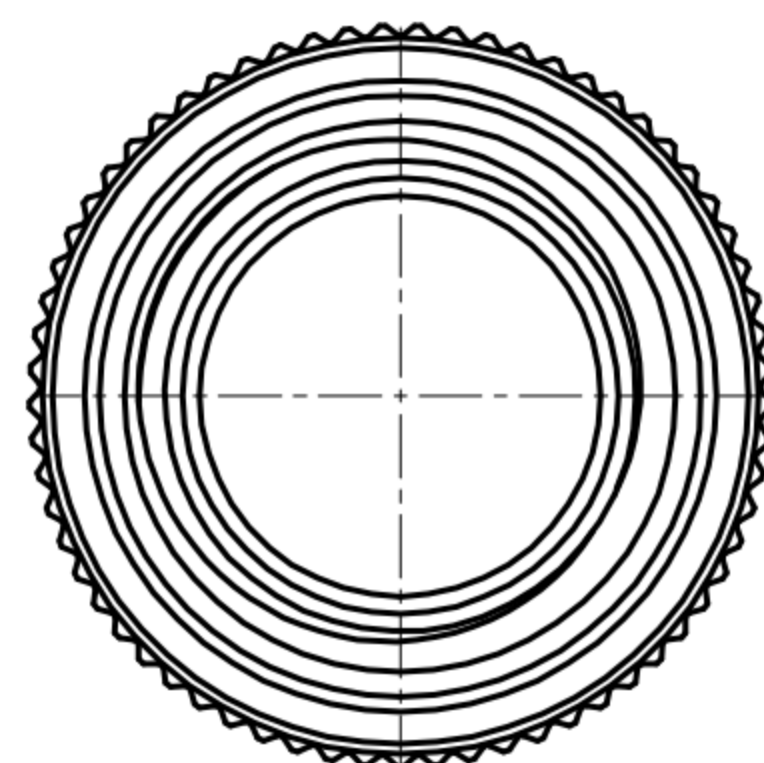

SHELL B + SHELL C + SPRING

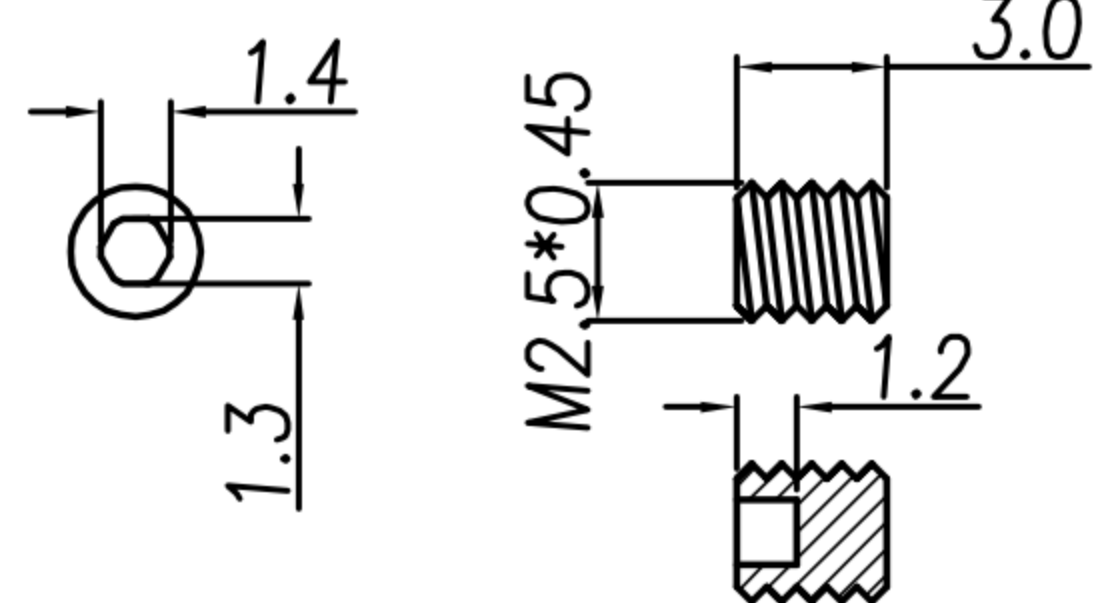
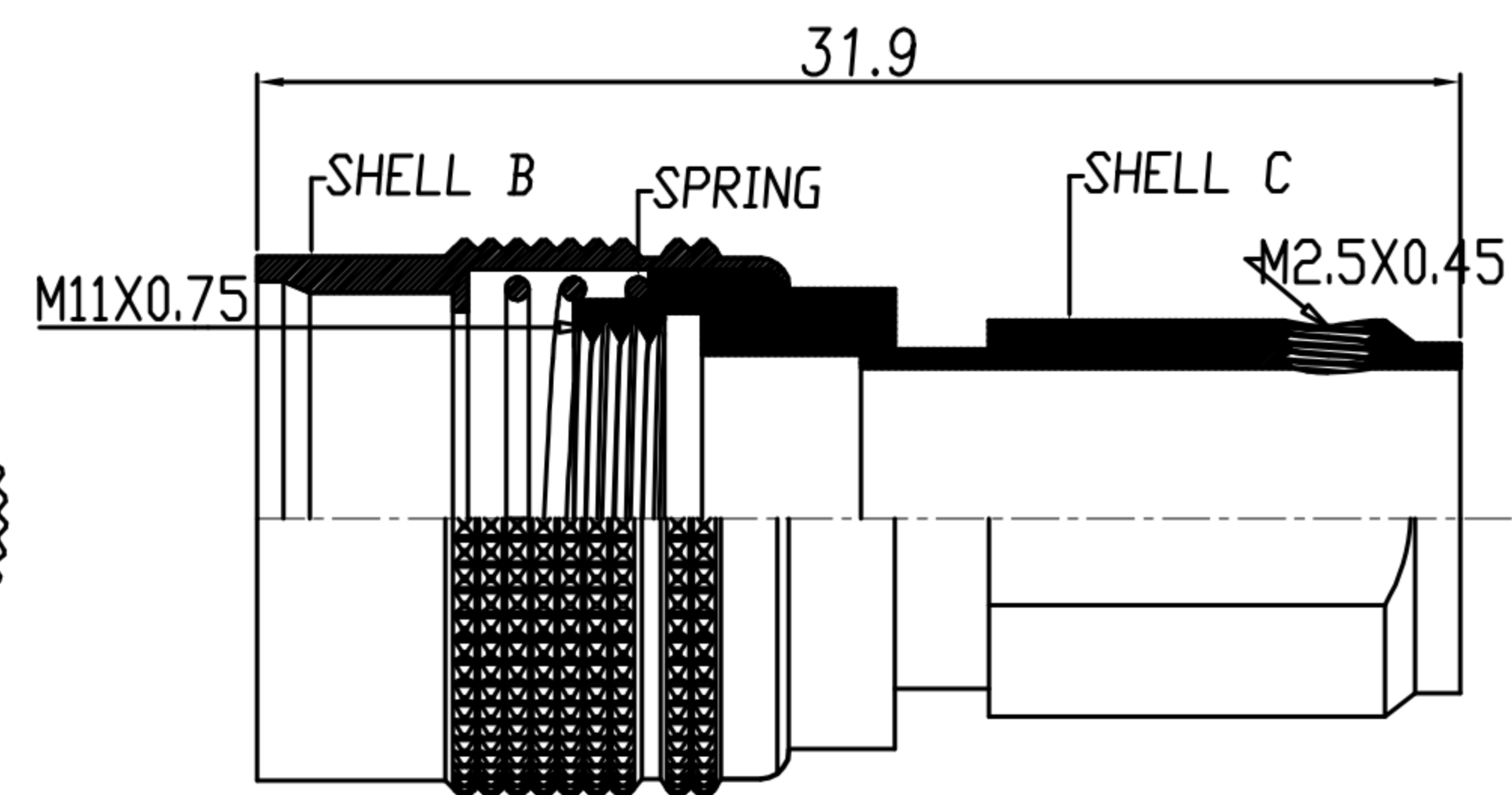

SCREW

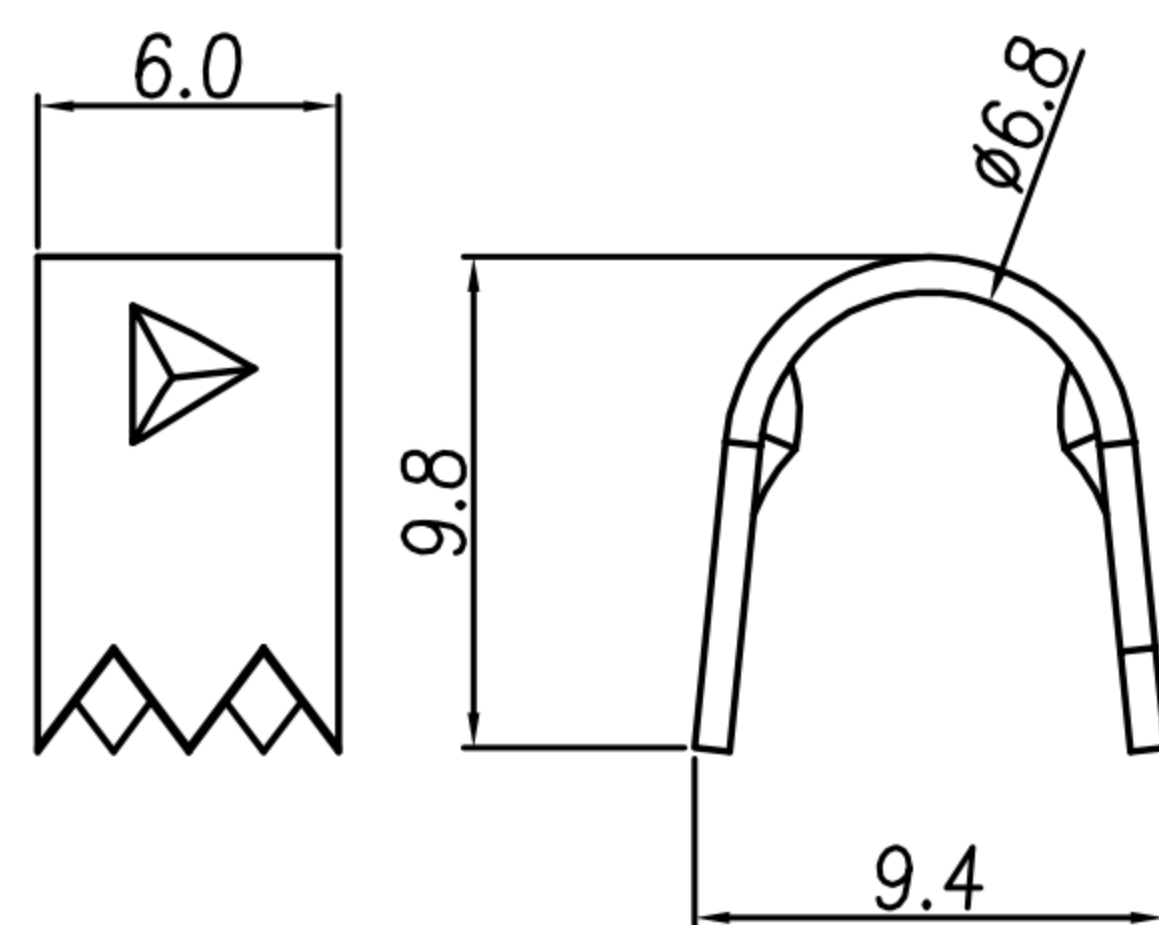

CRAMP

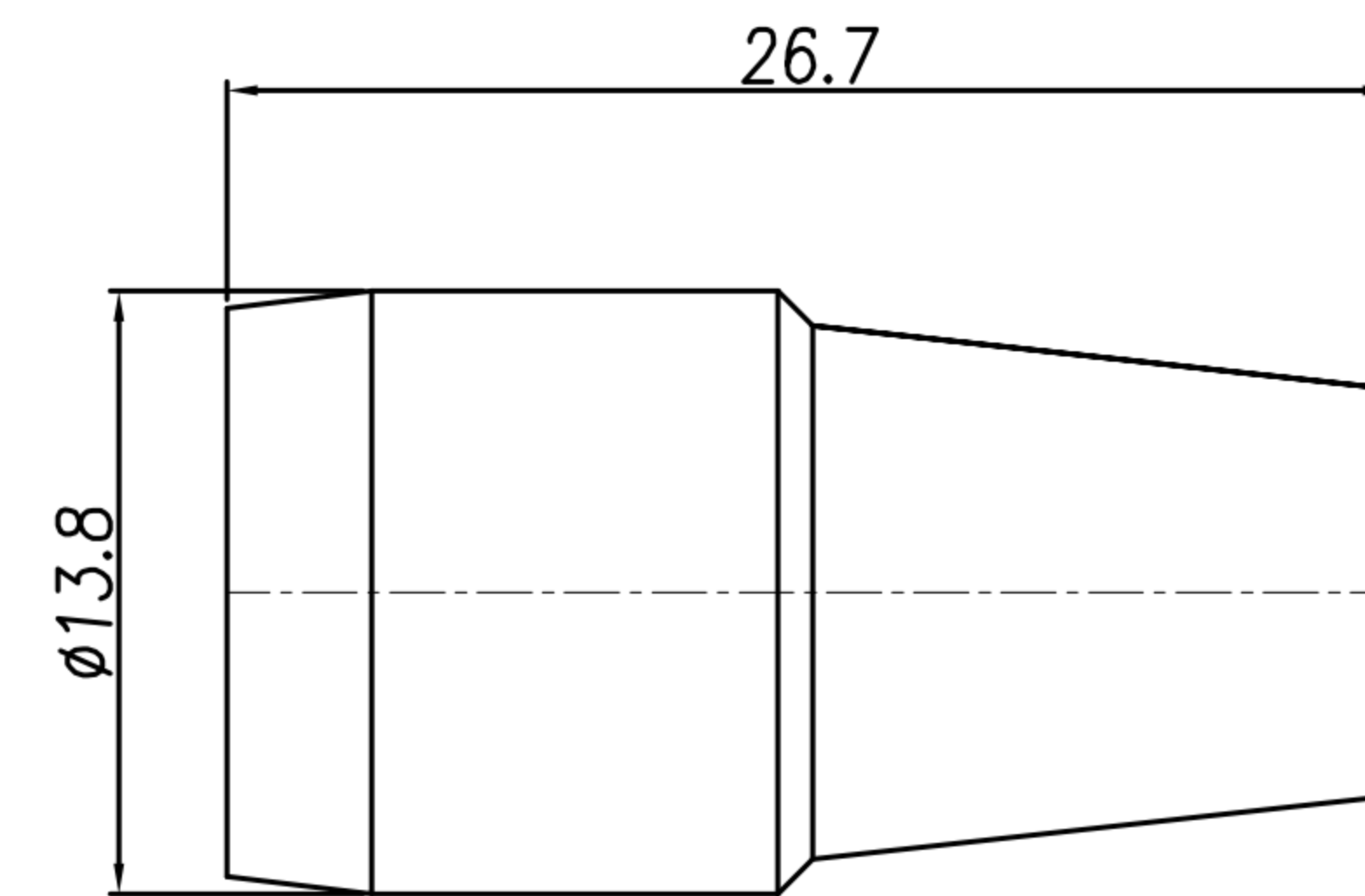
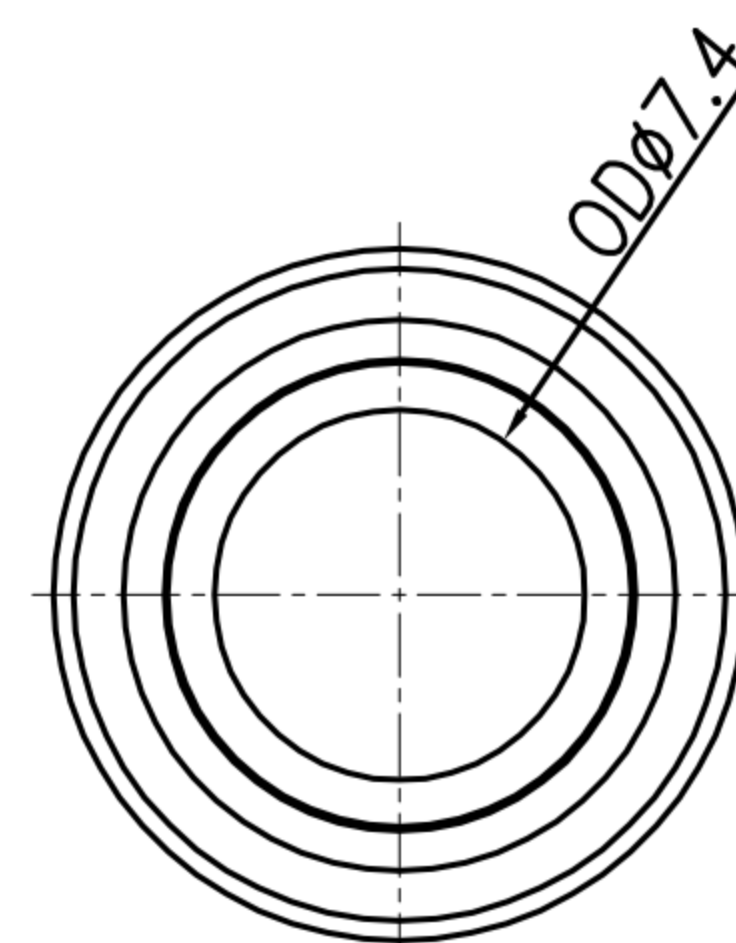

SR

DRAWN	Mark Kao	APPVL	Ku Chou	UNIT	mm	TOLERANCE		广东科斯达电子科技有限公司 GUANG DONG KE SI DA ELECTRONIC TECHNOLOGY CO., LTD.	TITLE	DIN (F) 插头式			SHEET	2
CHK'D	Emily Suen			SCALE	1:1	.x ±0.20 .xx ±0.10 .xxx ±0.05 .xxxx ±0.03 ANGULA ±1°			PART NO.	SEE TABLE A	DWG NO.	QC5517	VERSION	A



CUSTOMER DRAWING

REV.	DESCRIPTION	APPROVED BY	DATE	ECN NO.
△A	RELEASE	Emily Suen	22/08/11*	
△B	CHANGE MATERIAL	Emily Suen	16/09/22*	
△C				
△D				

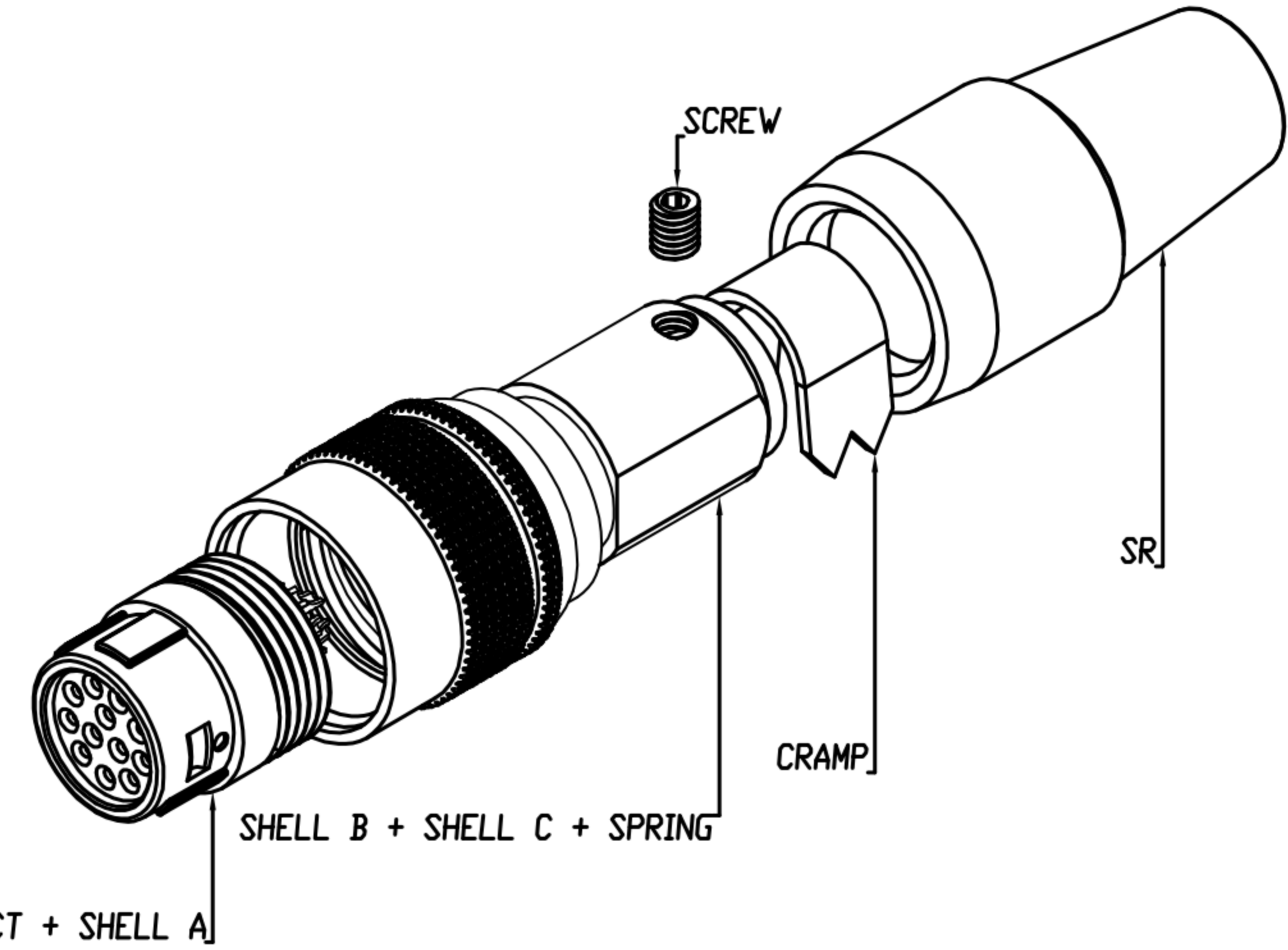
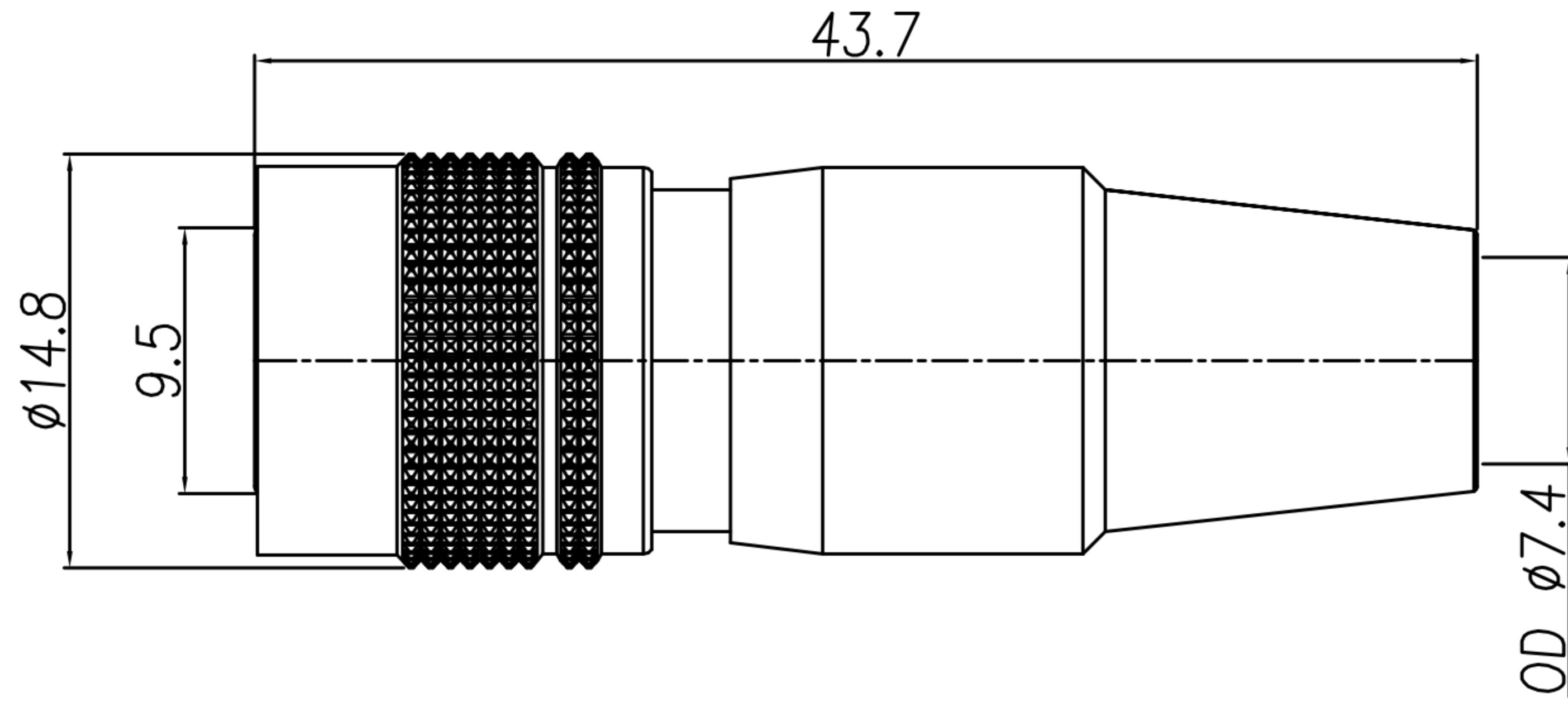

1. MATERIAL :

- △ 1-1. HOUSING : NYLON66 UL94V-0  
COLOR : BLACK
- 1-2. CONTACT : BRASS
- 1-3. SHELL A : ZINC ALLOY
- 1-4. SHELL B : BRASS
- 1-5. SHELL C : BRASS
- 1-6. SPRING : STAINLESS STEEL
- 1-7. SCREW : ALLOY STEEL
- 1-8. CLAMP : BRASS
- 1-9. SR : TPR ; COLOR : BLACK

2. FINISH :

- 2-1. CONTACT : GOLD FLASH
- 2-2. SHELL A : NICKEL
- 2-3. SHELL B : SATIN NICKEL
- 2-4. SHELL C : NICKEL
- 2-5. SPRING : NICKEL
- 2-6. SCREW : NICKEL

3. ELECTRICAL SPECIFICATION :

- 3-1. Rated current : 2A
- 3-2. Rated voltage : 100V AC / 140V DC

4. Environmental :

- 4-1. Operation Temperature : -25℃~85℃

TABLE A

CONTACT ARRANGEMENT & DIMENSIONS(FRONT VIEW)	
DI-12F2-01	DI-10F2-02

DRAWN	Mark Kao	APPVL	Ku Chou	UNIT	mm	TOLERANCE			TITLE	DIN (F) 插头式			SHEET
CHK'D	Emily Suen			SCALE	1:1	.x ±0.20 .xx ±0.10 .xxx ±0.05 .xxxx ±0.03 ANGULA ±1°			PART NO.	SEE TABLE A	DWG NO.	QC5517	