

REV.	DESCRIPTION	APPROVED BY	DATE	ECN NO.
△A	RELEASE	Fido Weng	01/10/10'	
△B	尺寸變更	Emily Suen	15/08/12'	ECN12020
△C	變更線路圖	KU	10/05/18'	

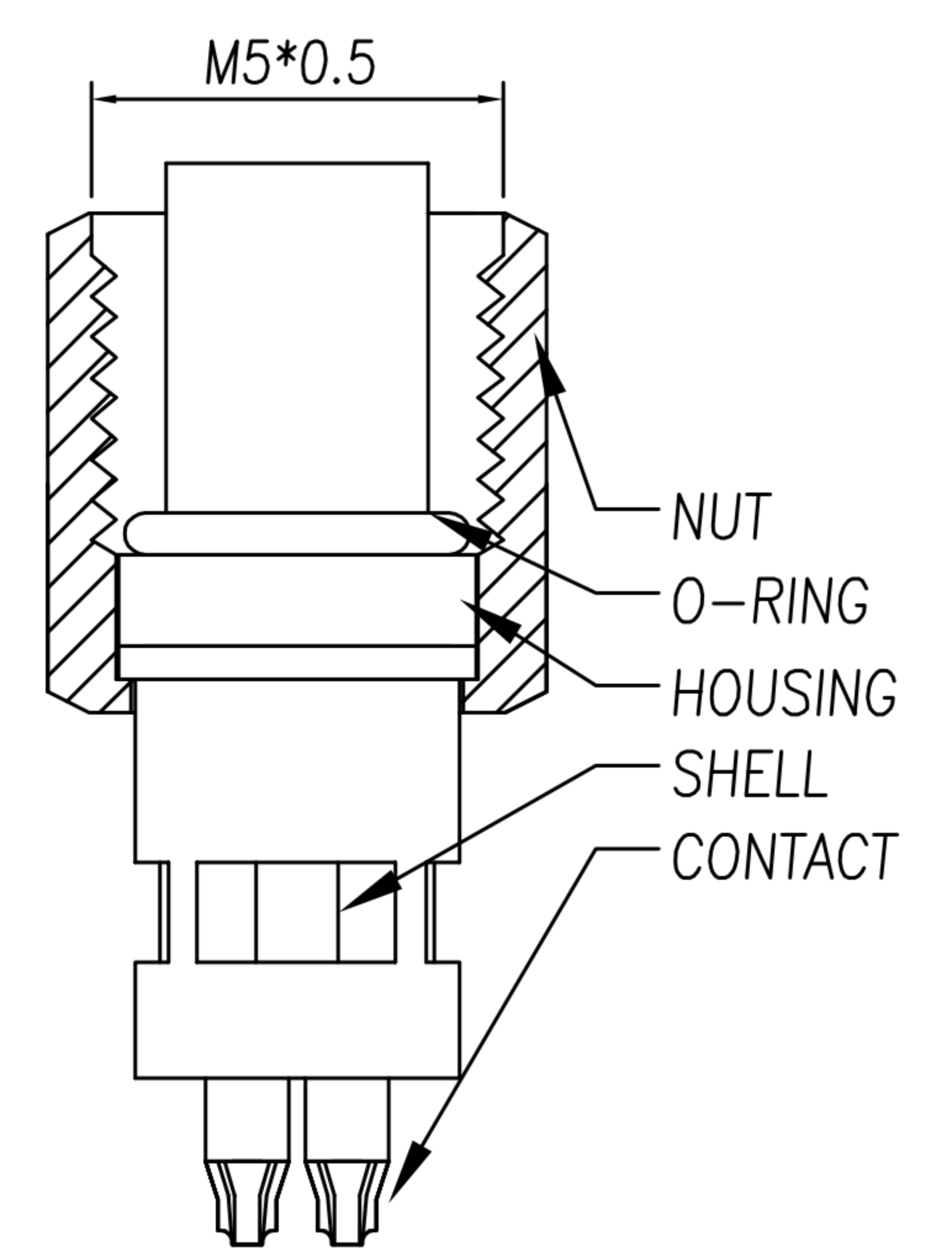

NUT

- MATERIAL :
  - 1-1. HOUSING : TPU ; COLOR : BLACK
  - 1-2. CONTACT : PHOSPHOR BRONZE
  - 1-3. NUT : BRASS
  - 1-4. O-RING : NBR ; COLOR : BLACK
  - 1-5. SHELL : BRASS.
- FINISH :
  - 2-1. CONTACT : SEE TABLE A
  - 2-2. NUT : SEE TABLE A
  - 2-3. SHELL : BRIGHT TIN PLATED .
- ELECTRICAL SPECIFICATION :
  - 3-1. Rated current : 1A
  - 3-2. Rated Voltage : 60V
  - 3-3. Water proof : IP67
- Environmental :
  - 4-1. Operation Temperature : -20 ℃~85℃

TABLE A

△	WP-04F2-175-11	GOLD FLASH	BLACK Cr
△	WP-04F2-144-11	GOLD 10u"	NICKEL 60u"~100u"
△	WP-03F2-65-11	GOLD 10u"	NICKEL 60u"~100u"
△	WP-02F2-41-11	GOLD 10u"	NICKEL 60u"~100u"
△	WP-04F2-56	GOLD FLASH	NICKEL 60u"~100u"
△	WP-03F2-60-11	GOLD FLASH	NICKEL 60u"~100u"
△	WP-02F2-37-11	GOLD FLASH	NICKEL 60u"~100u"
	PART NO	FINISH(CONTACT)	FINISH(NUT)

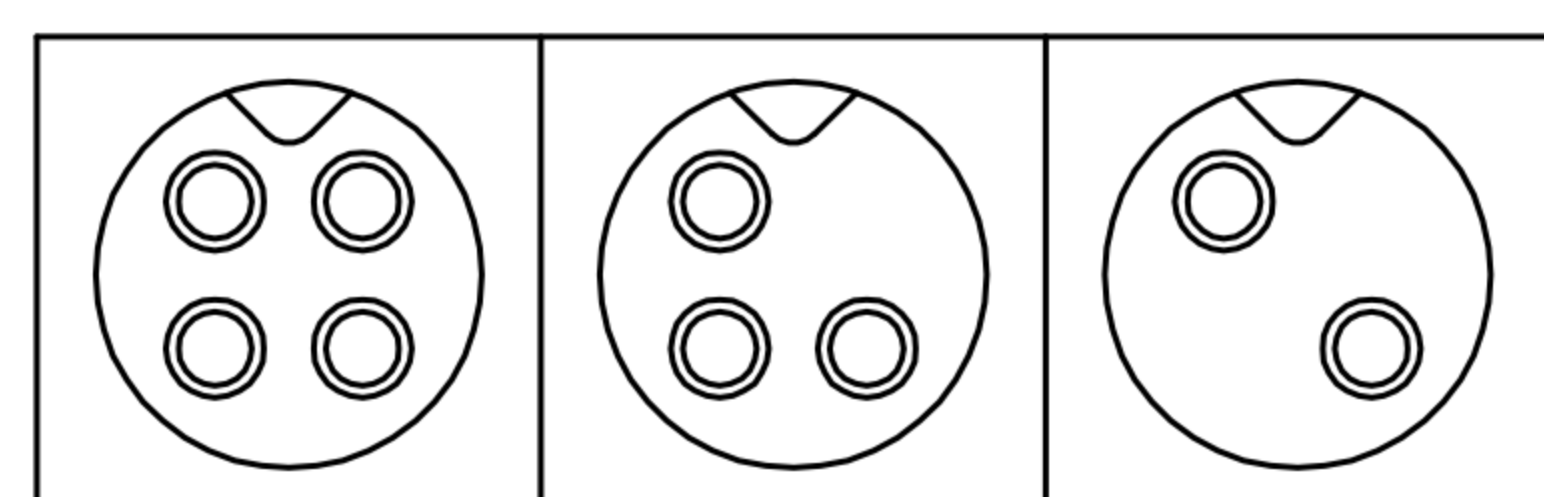

DRAWN	Ku Chou	APP'D	Emily Suen	UNIT	mm	TOLERANCE			TITLE	M5-4(F)線端線式+接地			SHEET	
CHK'D	Emily Suen			SCALE	1:1	.x ±0.20 .xx ±0.10 .xxx ±0.05 .xxxx ±0.03 ANGULA ±1°			PART NO.	SEE TABLE A	DWG NO.	QC4999	VERSION	